

## Cat5e Cable Wiring Schemes

This document was written in efforts to provide basic background information regarding the 568A and 568B wiring standards. It will also define the differences between and these standards. In addition, we will provide the steps on how to create standard and crossover cables.

Both the 568A and 568B are the two color code schemes used to correctly wire the RJ45 eight-position modular plugs. These two color codes are approved by the American National Standard Institute/Telephone Industry Association/Electronics Industry Association (ANSI/TIA/EIA) wiring standards. There is no difference, whatsoever, between the two wiring schemes, in connectivity or performance when connected from one device to another, so long as the devices are wired for the same scheme. The only time when one scheme has an advantage over the other, is when one end of a segment is connected to a modular device, and the other end to a punch block. In which case, the 568A has the advantage of having a more natural progression of pairs at the punch block side.

Cables are generally made up of 8 wires twisted together in 4 pairs. Each pair is easily identified by one of four primary colors and is intended to carry a signal and its return. The 568A wiring pattern is recognized as the preferred wiring scheme for standard because it provides backward compatibility for both one pair and two pair Universal Service Order codes (AT&T) USOC wiring. U.S. Government regulations require the use of the preferred 568A standard for wiring installed under federal contracts. However, N-Tron adopted the 568B standard since it is the most widely used in the industry today. It matches the older AT&T 258A color code. It is also approved by the ANSI/TIA/EIA standard. This scheme provides one pair for backward compatibility to the USOC wiring scheme. This illustration will assist you in identifying the differences between the 568A and 568B color schemes. The difference between the two schemes is that the orange and green pairs are interchanged as shown here. These standards specify a maximum segment length of 100 meters (328 feet) between two devices. This length includes patch panels and cables. When longer distances are desired, the use of switches, repeaters, or fiber optic media may be required.

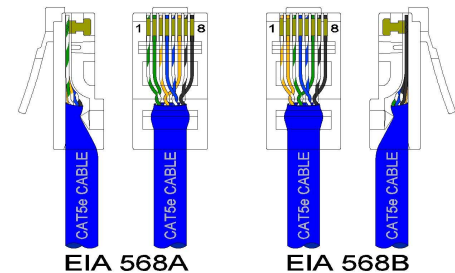

A cable can be wired with correct continuity, but not with correct pairing. This often happens when the cable is terminated consistently at both ends, but in the wrong order. A dynamic or AC test is required to detect this type of error. If the only error is a split pair error, the cable has correct continuity and will likely cause crosstalk. Crosstalk is the bleeding of signals carried by one pair of conductors, onto another pair through the electrical process of induction. The conductors do not need to make contact with each other as the crosstalk is transferred magnetically. This is an unwanted effect that can cause slow transfer or completely inhibit the transfer of data signals over a long cable segment. The purpose of the wire twists found in Cat5e cable is to significantly reduce the crosstalk and its side effects. Similarly, Electro Magnetic Interference (EMI) is an unwanted signal that is induced into the cable. The difference is that EMI is typically induced from a source that is external to the cable. This could be an electrical power cable or device, or in some cases adjacent Cat5e cables that do not adhere to the 568A and 568B standards. Attenuation is the loss of signal in a cable segment due to the resistance of the wire plus other electrical factors that cause additional resistance. Longer cable length, poor connections, bad insulation, high levels of crosstalk, and EMI will all increase the total level of attenuation. The 568A and 568B standards were developed to provide more effective communications for longer distances in a Cat5e cable segment than using non-standard schemes. Fiber Optic cable is the only medium that is completely immune to crosstalk and EMI since it uses light to transfer data instead of electrical current.

## Creating Cat5e Standard and Crossover Cables

Before you begin creating standard Cat5e patch cables, it is important to point out that the method outlined here is only one method. It is by no means the best method. Also, make sure you have all the necessary tools and materials before you begin. You will need a length of Cat5e certified cable and several RJ-45 connectors. For best results, we recommend using a quality ratcheting tool such as the popular IDEAL Telemaster™ Tool for cutting and terminating RJ-45 plugs.

1. Most crimp tools have two blades: one designed to cut through a cable completely and the other designed to help remove the cable's outer jacket. Use the first blade to cut the cable to length. Then, use the second blade to strip the cable's outer jacket to remove about an inch, so that all the wires inside are exposed. Be careful not to cut the inside wires when stripping the cable's jacket insulation.
2. With the jacket removed, you'll find eight wires within the Cat5e cable. If a string is present, cut the string off, and untwist the wires back to within one-eighth inch of the jacket.
3. Fan the wires out from left to right in the order they are to be crimped. Using the same color scheme (568A or 568B) at both ends will create a standard patch cable as shown in the 568A-568A and 568B-568B illustrations below.
4. With the wires aligned and flattened out, use the cutting blade to evenly trim the wires while leaving approximately one half inch exposed.
5. With the clip facing away from you, carefully insert the wires into the RJ45 connector as shown below.
6. Once two RJ45 connectors have been installed at both ends, you will need to determine the quality of all connections to ensure the pinouts have been terminated properly. This is a very important step that is often overlooked mostly due to the expense of the testing equipment. The LanRover Pro TP600 will assist you in identifying shorts, opens, miswires, reversals, and split pairs. In addition, this professional tester will help determine the final length of the cable you made.

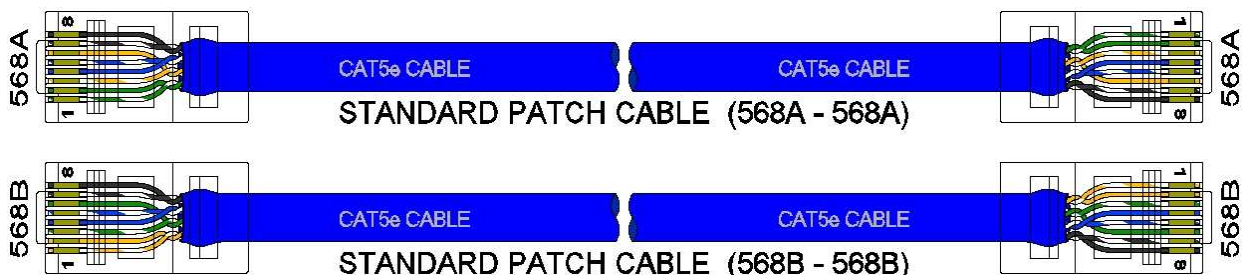

Two Ethernet switches may be connected together with a standard patch cable as long as both devices are compliant with the MDIX standard. N-Tron Ethernet switches use this technology on all 10/100 RJ45 ports. Basically, the MDIX standard automatically performs the crossover functions without user configuration. It allows the switch to properly align the conductors internally. In some situations, connection of similar devices such as legacy hubs or Network Interface Cards (NIC's) may be accomplished by the use of a cross-over cable. Therefore, the cable itself will physically perform the crossover function. A crossover cable can be easily created by using the 568A scheme at one end and the 568B scheme at the other end as shown in the 568A-568B illustration below.

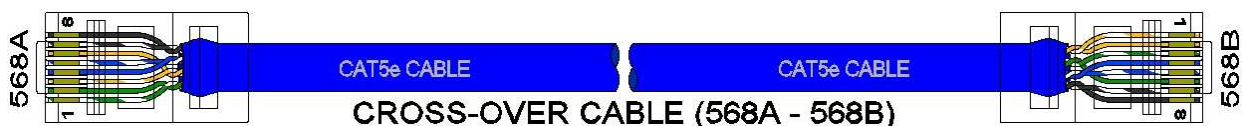

## Shielded Cat5e Cable Detail

The use of shielded cables between devices is not required for most N-Tron devices (please consult the user manuals for specific details). If the use of shielded cables is required, it is generally recommended to only connect the shield at one end to prevent ground loops and interfere with low level signals (i.e. thermocouples, RTD, etc.). Cat5e cables manufactured to EIA-568A or 568B specifications are required for use with N-Tron Switches.



In the event all Cat5e patch cable distances are small (i.e. All Ethernet devices are located the same local cabinet and/or referenced to the same earth ground), it is permissible to use fully shielded cables terminated to chassis ground at both ends in systems void of low level analog signals.

## Cat5e 568A and 568B Pinout Detail

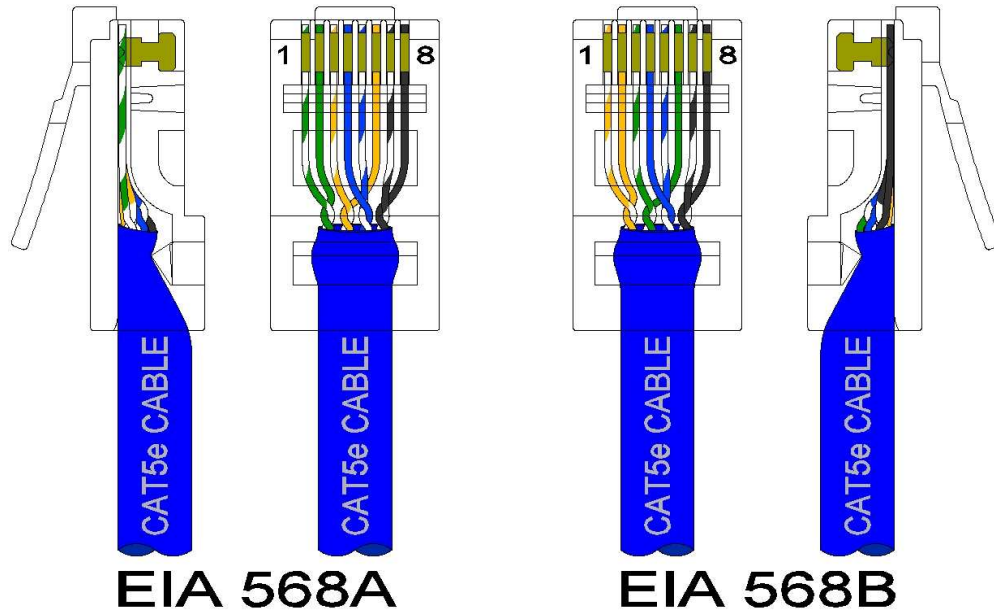

EIA 568A		
Pin #	Wire Color Legend	Signal
1	White/Green	TX+
2	Green	TX-
3	White/Orange	RX+
4	Blue	TRD2+
5	White/Blue	TRD2-
6	Orange	RX-
7	White/Brown	TRD3+
8	Brown	TRD3-

EIA 568B		
Pin #	Wire Color Legend	Signal
1	White/Orange	TX+
2	Orange	TX-
3	White/Graenge	RX+
4	Blue	TRD2+
5	White/Blue	TRD2-
6	Green	RX-
7	White/Brown	TRD3+
8	Brown	TRD3-