

Installation Guide
10BASE-T/10BASE-FL
Ethernet Media Converter

NC-10TFT / NC-10TFC

Table of Contents

1. General Description.....	P3
1.1 Specifications.....	P3
2. Connectors & Cables.....	P4
2.1 10BASE-T UTP Cable.....	P4
2.2 Fiber Optic Connector(Fiber Port).....	P5
3. Installation.....	P6
3.1 Install the media converter with the DC power supply.....	P6
3.2 Making Network Connections.....	P7
4. Interpreting LED Indicators.....	P8

1 General Description

The NC-10TF Ethernet media converter series are designed to convert a 10BASE-T signal to a 10BASE-FL signal. It is used to extend the connection distance between two Ethernet Twisted-pair devices via fiber cable transparently with no performance degradation. The converter series provide different types of fiber connectors such as ST and SC for MM(multimode) fiber cables.

The outline of the converter is :

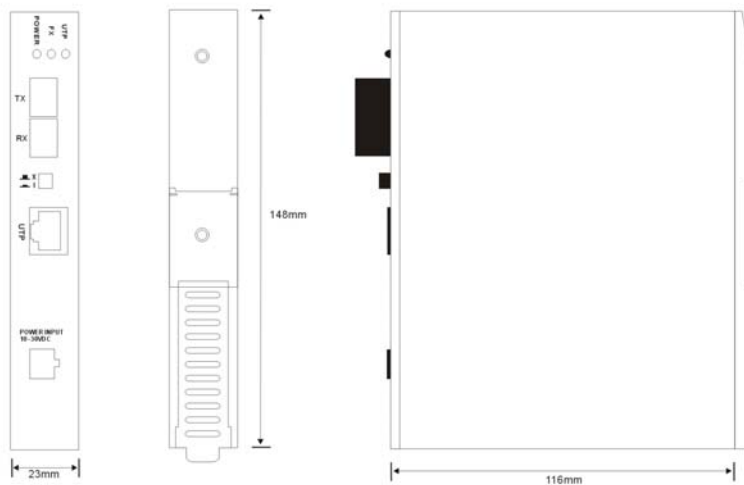

1.1 Specifications

- Comply with IEEE802.3 10BASE-T and 10BASE-FL std.
- Provide a push button to set the crossover function for the TP port
- Provide LEDs for easy network monitoring:
 - Power status
 - Link and receive status for TP port
 - Link and receive status for fiber port
- Fiber optic connectors:
 - Multimode ST : (NC-10TFT)
 - Multimode SC : (NC-10TFC)
- Environment: Temperature 0-40⁰C
Humidity 10-90% non condensing
- Dimensions : 23mm x 148mm x 116mm
- Power : +10V~30VDC
- Power consumption : 10W

2 Connectors & Cables

10BASE-T RJ Connectors(TP Port)

One RJ-45 connector is provided on the converter for 10BASE-T connection. For easy connection to any device using standard straight-through UTP cable, a push button is available to set the crossover function for the RJ-45.

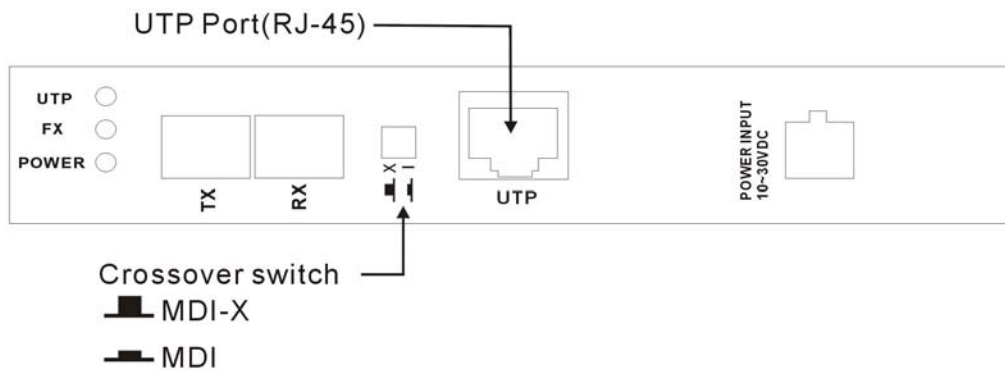

RJ-45 Pin	MDI-X Jack	MDI Jack
1	RX+	TX+
2	RX-	TX-
3	TX+	RX+
6	TX-	RX-

2.1 10BASE-T UTP Cable

Cable : Category 3, 4, or 5 UTP

Maximum cable distance : 100 meters(328feet)

2.2 Fiber Optic Connector(Fiber Port)

The series provides different types of fiber connectors for different applications. The connectors include multimode ST, multimode SC are shown as follows :

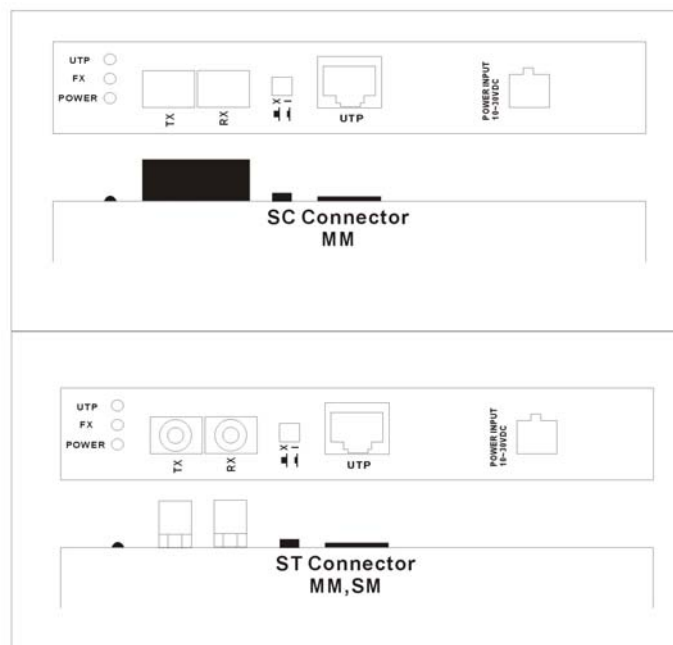

The Wavelength used is 850nm. The series also support MM(multimode) fiber cables. The recommended MM cable is 62.5/125 μ m.

Models

The following table lists the fiber connectors, fiber cables and the maximum length supported by each converter model :

Model	Connector	Cable Used	Cable Length*
NC-10TFT	ST	MM	2Km
NC-10TFC	SC	MM	2Km
NC-200TFT	ST	MM	2Km
NC-200TFC	SC	MM	2Km

*Cable length : the maximum length in point-to-point full duplex operation

3 Installation

3.1 Install the media converter with the DC power supply

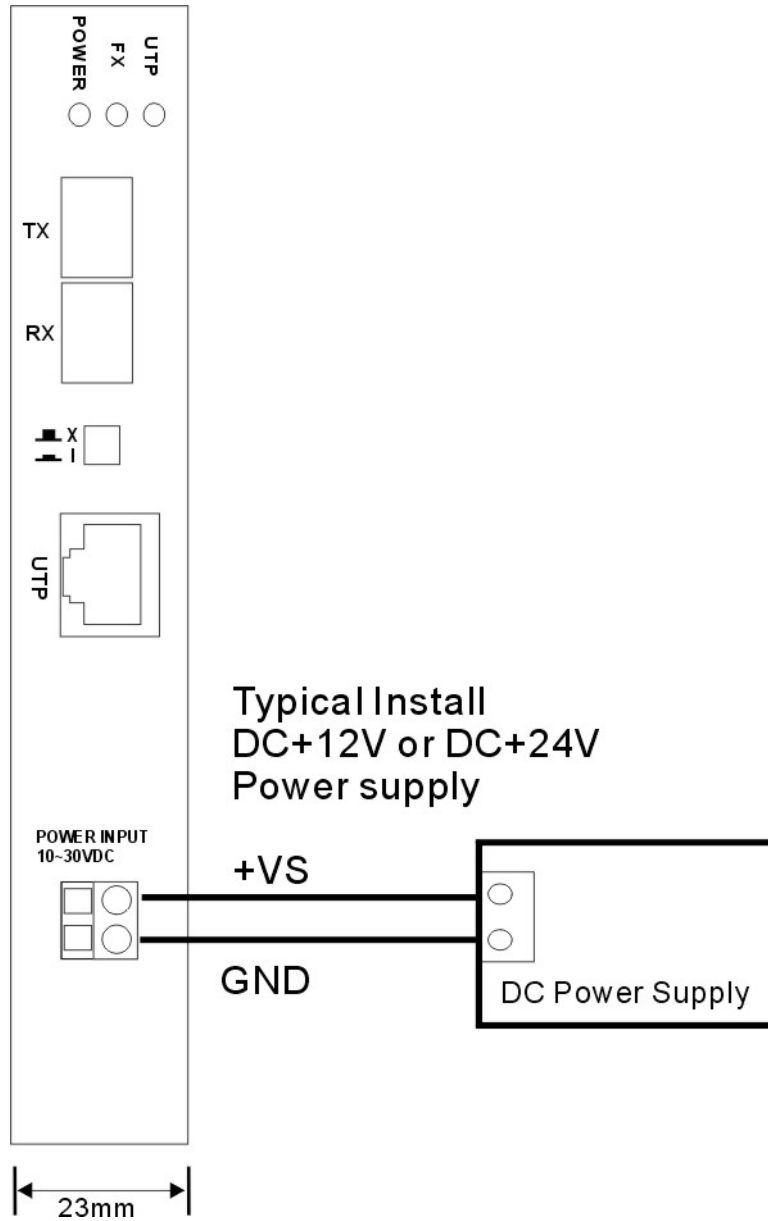

3.2 Making Network Connections

The converters serve as a conversion path between two Ethernet devices. To both devices, the conversion is transparent. The connection could be one of the following configurations :

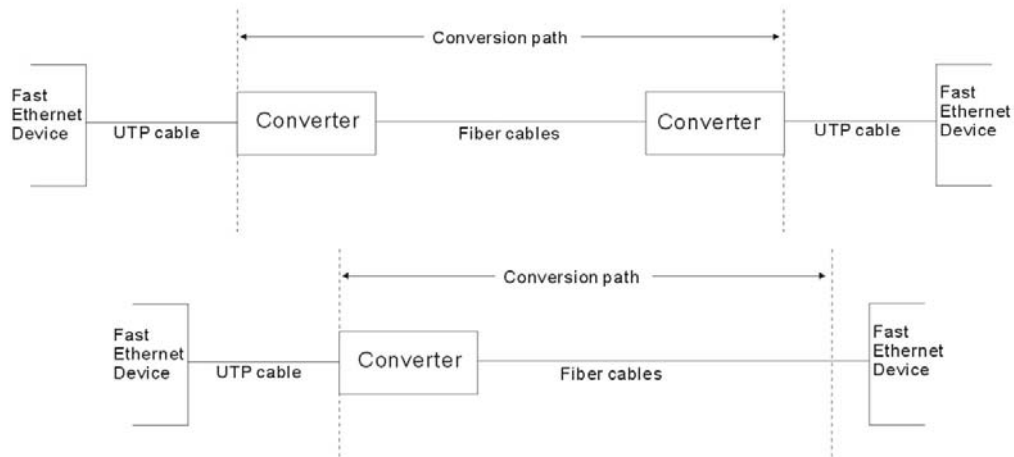

Important rule : When a connection is established, make sure the devices located at both ends of the path are configured and operated using the same duplex mode and the maximum distance must comply with IEEE 802.3u specifications.

The following figure illustrates a connection example between two auto-negotiation devices. Both devices operate in full-duplex mode after a negotiation process with the converters.

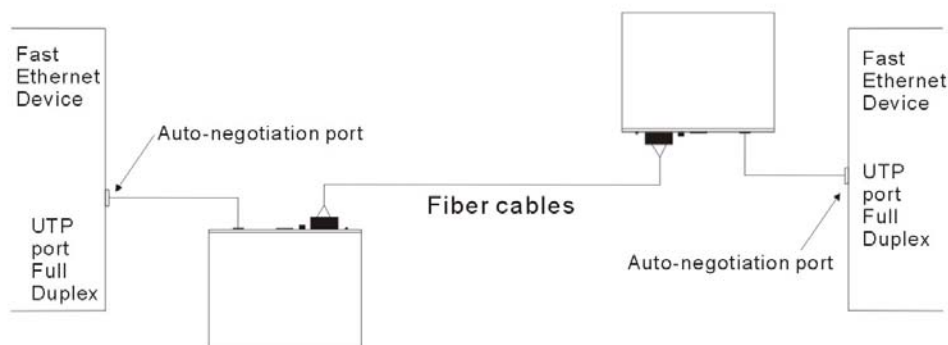

4 Interpreting LED Indicators

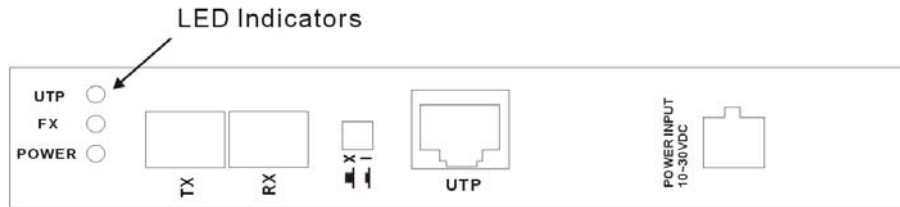

The LED labeled “UTP” is used to indicate the status of the TP port and the LED labeled “FX” is for Fiber port.

LED	Status	State	Interpretation
POWER	Power status	On	Converter is on.
		Off	Converter is off.
UTP	TP port link/Rx	On	The UTP link is ok.
		Off	No link or the link is faulty.
		Blink	Receiving on TP port
FX	Fiber port link/RX	On	The fiber link is ok.
		Off	No link or the link is faulty.
		Blink	Receiving on Fiber port

The information contained in this document is subject to change without prior notice.