

Advantages of the Class 6 Solid State Relay

The Complete System Solution!



Optional Heat Sink
(SSR-HS-1)
Section 3 p.20



Optional Thermal Pad
(SSR-TP-1)
Section 3 p.21

We at Magnecraft strive to be your one-stop-shop for all of your solid state relay needs. The new line of 6 series solid-state relays give industrial relay users an energy-efficient current switching alternative. Depending on the application, these solid-state relays offer a number of advantages over electromechanical relays, including longer life cycles, less energy consumption and reduced maintenance costs. This is why great care and attention was given when developing the next generation of "Hockey Puck" style SSRs. These new SSRs will be finger-safe, fit a pre-cut heat transfer thermal pad (sold separately) and have the ability to be mounted onto a factory tested pre-drilled and tapped heat sink (sold separately).

Magnecraft's expertise in both SSR design and thermal management enables us to provide customers with a solution to their solid state relay requirements. This solution comes ready-to-use, virtually eliminating in-house assembly and complex heat sink calculations. Furthermore, each SSR, thermal pad (sold separately) and heat sink assembly (sold separately) utilizes the reliability and technology only available in our 6 series solid state relays. These features, coupled with Magnecraft's superior customer service and engineering support team, provide our customers with a level of convenience not easily found in the market today!



Evolu

Legacy

The Class 6 is also available with Blade Terminals.



The new finger-safe Class 6* "Hockey Puck" Style Solid State Relay (SSR) expands and enhances the current Magnecraft Solid State Relay product line.

This product features a finger-safe cover and LED Status Indicator. The optically coupled circuitry isolates the input from the output to give pure solid state performance. This product carries with it agency certifications from UL, CSA, and CE.

*Available for products up to 40 Amps (AC Load) and 12 Amps (DC Load).

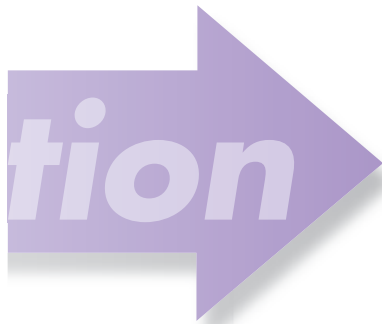

Finger Safe
Protects Operators from live circuits.

Input Indication
Green LED.

Optically Coupled Circuit
NO Interference between separate circuits.

Solid State Circuitry
No Moving Parts Involved.

Internal Snubber
Protects from Transients.

Panel Mounting



New

Class 6 Solid State Relays/SPST-NO, SPST-NC, DPST-NO, 10-125 Amp Rating



NEW
NEW
NEW
NEW
NEW

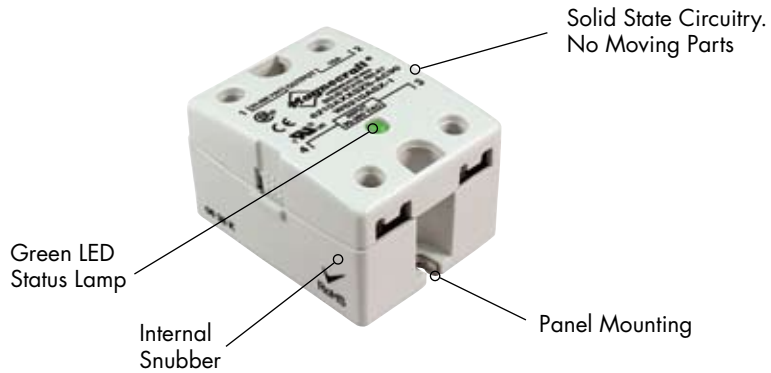

General Specifications (@ 25° C) (UL 508)

	New Part # Superceding Part #	Units	6210AXXSZ5-AC90 6210ASX-1
Output Characteristics			
Number and type of Contacts			SPST-NO
Switching Device			SCR (2)
Current rating		A	10
Switching voltage		V	24....280 AC
Switching Type			Zero Cross
Maximum Rate of Rise Off State Voltage (dv/dt)		V/us	200
Incandescent Lamp Ampere Rating (rms)		A	8
Motor Load Rating (rms)		A	4.5
Min. Load current to maintain on		mA	50
Non-Repetitive Surge Current (1 cycle)		A	83
Max. RMS overload current (1 second)		A	24
Max. Off state leakage current (rms)		mA	8
Peak Blocking Voltage		Vpk	600
Typical On State Voltage Drop (rms)		V	1.6 AC
Max. On State Voltage Drop (rms)		V	1.6 AC
Maximum I ² T for Fusing (A ²)			72
Input Characteristics			
Voltage Range		V	90...280 AC/80...140 DC
Must Release Voltage		V	10 AC
Nominal Input Impedance		Ω	13K
Typical Input Current @ 5VDC or 240VAC		mA	20
Reverse Polarity Protection			N/A
Performance Characteristics			
Operating Time (response time)	On	ms	8.3
	Off	ms	8.3
Rated Insulation Voltage	Input to Output	V	4000 AC
Dielectric strength	Terminals to Chassis	V	4000 AC
Environment			
Product certifications	Standard version		UR, CSA, CE
Ambient air temperature around the device	Storage	°C	-40...+100
	Operation	°C	-40...+80
Degree of protection			IP 20
Miscellaneous Characteristics			
Thermal Resistance (Junction to Case)		°C/W	3.5
Weight		g (oz)	100 (3.5)
LED	Input		Green
Input Terminals			M3.5
Output Terminals			M4
Mounting Screw Torque		Nm	1.0

SECTION 4



**Thermal Pad
(SSR-TP-1)**
Section 3 p.21



**Blade Terminals
(DPST-NO)**



**Heat Sink
(SSR-HS-1)**
Section 3 p.20

6225AXXSZS-AC90	6250AXXSZS-AC90	6275AXXSZS-AC90	6210AXXSZS-DC3	6225AXXSZS-DC3
6225ASX-1	6250ASX-1	6275ASX-1	6210DSX-1	6225DSX-1
SPST-NO	SPST-NO	SPST-NO	SPST-NO	SPST-NO
SCR (2)	SCR (2)	SCR (2)	SCR (2)	SCR (2)
25	50	75	10	25
24...280 AC	24...280 AC	24...280 AC	24...280 AC	24...280 AC
Zero Cross	Zero Cross	Zero Cross	Zero Cross	Zero Cross
500	500	500	200	500
16	39	39	8	16
8	14	25	4.5	8
120	250	250	50	120
250	520	1150	83	250
40	100	150	24	40
8	10	10	10	10
600	600	600	600	600
1.6 AC	1.1 AC	1.8 AC	1.6 AC	1.6 AC
1.6 AC	1.8 AC	1.8 AC	1.6 AC	1.6 AC
312	1250	5000	83	250
90...280 AC/80...140 DC	90...280 AC/80...140 DC	90...280 AC/80...140 DC	3...32	3...32
10 AC	10 AC	10 AC	1 DC	1 DC
13K	13K	13K	Current Regulator	Current Regulator
20	20	20	16	16
N/A	N/A	N/A	Yes	Yes
8.3	8.3	8.3	8.3	8.3
8.3	8.3	8.3	8.3	8.3
4000 AC	4000 AC	4000 AC	4000 AC	4000 AC
4000 AC	4000 AC	4000 AC	4000 AC	4000 AC
UR, CSA, CE	UR, CSA, CE	UR, CSA, CE	UR, CSA, CE	UR, CSA, CE
-40...+100	-40...+100	-40...+100	-40...+100	-40...+100
-40...+80	-40...+80	-40...+80	-40...+80	-40...+80
IP 20	IP 20	IP 20	IP 20	IP 20
1.02	0.63	0.6	3.50	1.02
100 (3.5)	135 (4.8)	200 (7.1)	100 (3.5)	100 (3.5)
Green	Green	Green	Green	Green
M3.5	M3.5	M3.5	M3.5	M3.5
M4	M6	M6	M4	M4
1.0	1.0	1.0	1.0	1.0

Class 6 Solid State Relays/SPST-NO, SPST-NC, DPST-NO, 10-125 Amp Rating *continued*



NEW
NEW
NEW
NEW
NEW

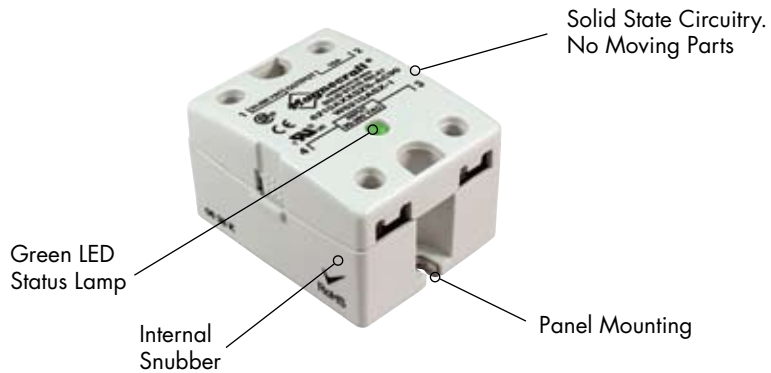

General Specifications (@ 25° C) (UL 508)

	New Part # Superceding Part #	Units	6250AXXSZS-DC3 6250DSX-1	6275AXXSZS-DC3 6275DSX-1
Output Characteristics				
Number and type of Contacts			SPST-NO	SPST-NO
Switching Device			SCR (2)	SCR (2)
Current rating		A	50	75
Switching voltage		V	24...280 AC	24...280 AC
Switching Type			Zero Cross	Zero Cross
Maximum Rate of Rise Off State Voltage (dv/dt)		V/us	500	500
Incandescent Lamp Ampere Rating (rms)		A	39	39
Motor Load Rating (rms)		A	14	25
Min. Load current to maintain on		mA	250	250
Non-Repetitive Surge Current (1 cycle)		A	520	1150
Max. RMS overload current (1 second)		A	100	150
Max. Off state leakage current (rms)		mA	8	10
Peak Blocking Voltage		Vpk	600	600
Typical On State Voltage Drop (rms)		V	1.8	1.8
Max. On State Voltage Drop (rms)		V	1.8	1.8
Maximum I ² T for Fusing (A ²)			1250	5000
Input Characteristics				
Voltage Range		V	3...32	3...32
Must Release Voltage		V	1 DC	1 DC
Nominal Input Impedance		Ω	Current Regulator	Current Regulator
Typical Input Current @ 5VDC or 240VAC		mA	16	16
Reverse Polarity Protection			Yes	Yes
Performance Characteristics				
Operating Time (response time)	On	ms	8.3	8.3
	Off	ms	8.3	8.3
Rated Insulation Voltage	Input to Output	V	4000 AC	4000 AC
Dielectric strength	Terminals to Chassis	V	4000 AC	4000 AC
Environment				
Product certifications	Standard version		UR, CSA, CE	UR, CSA, CE
Ambient air temperature around the device	Storage	°C	-40...+100	-40...+100
	Operation	°C	-40...+80	-40...+80
Degree of protection			IP 20	IP 20
Miscellaneous Characteristics				
Thermal Resistance (Junction to Case)		°C/W	0.63	0.6
Weight		g (oz)	135 (4.8)	200 (7.1)
LED	Input		Green	Green
Input Terminals			M3.5	M3.5
Output Terminals			M6	M6
Mouniting Screw Torque		Nm	1.0	1.0

SECTION 4



**Thermal Pad
(SSR-TP-1)**
Section 3 p.21



**Blade Terminals
DPST-NO**



**Heat Sink
(SSR-HS-1)**
Section 3 p.20

6210AXXTZS-DC3	6425BXXTZB-DC3*	6312AXXMDS-DC3	6325AXXMDS-DC3	6340AXXMDS-DC3
6210DTX-1	6425DTX-3*	6212DDX-1	6225DDX-1	6240DDX-1
SPST-NO	DPST-NO	SPST-NO	SPST-NO	SPST-NO
Triac	Alternistor	MOSFET	MOSFET	MOSFET
10	25	12	25	40
24....280 AC	48....480 AC	3....200 DC	3....200 DC	3....200 DC
Zero Cross	Zero Cross	DC Switching	DC Switching	DC Switching
250	250	N/A	N/A	N/A
16	N/A	N/A	N/A	N/A
8	N/A	N/A	N/A	N/A
120	80	20	20	20
250	250	27	50	90
80	80	N/A	N/A	N/A
10	10	8	8	8
300	300			
1.6	1.1	1.6	1.6	1.6
1.6	1.6	2.83	2.83	2.83
300	200	N/A	N/A	N/A
<hr/>				
3....32	3.5....32	3....32	3....32	3....32
1 DC	1 DC	1 DC	1 DC	1 DC
1.5 K	Current Regulator	1K	1K	1K
2	16	10	10	10
Yes	Yes	No	No	No
<hr/>				
8.3	8.3	300 μs	600 μs	600 μs
8.3	8.3	1	2.6	2.6
4000 AC	4000 AC	4000 AC	4000 AC	4000 AC
4000 AC	4000 AC	2500 AC	2500 AC	2500 AC
<hr/>				
UR, CSA, CE	UR, CSA, CE	UR, CSA, CE	UR, CSA, CE	UR, CSA, CE
-40...+100	-40...+100	-40...+100	-40...+100	-40...+100
-40...+80	-40...+80	-40...+80	-40...+80	-40...+80
IP 20	IP 20	IP 20	IP 20	IP 20
<hr/>				
1.45	1.20	1.06	1.06	1.06
100 (3.5)	100 (3.5)	110 (3.9)	135 (4.8)	135 (4.8)
Green	Green	Green	Green	Green
M3.5	0.187" QC	M3.5	M3.5	M3.5
M4	0.250" QC	M4	M4	M4
1.0	1.0	1.0	1.0	1.0

*Blade Terminal

Class 6 Solid State Relays/SPST-NO, SPST-NC, DPST-NO, 10-125 Amp Rating *continued*



NEW
NEW
NEW
NEW
NEW



Screw Terminals
SPST-NO



Blade Terminals
DPST-NO

*Finger-safe safety cover is available for products up to 40 Amps.

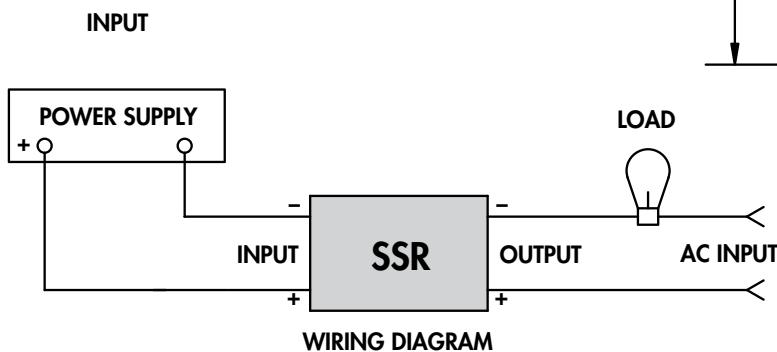
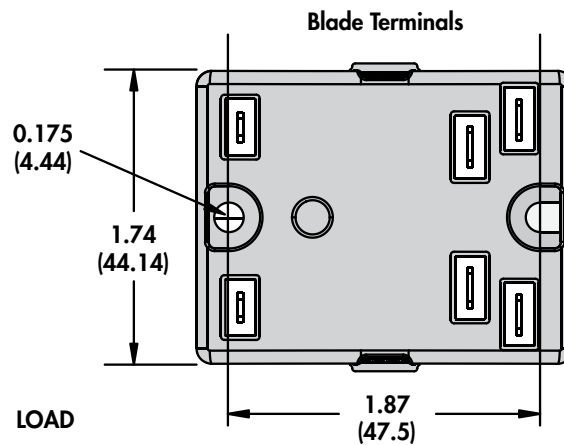
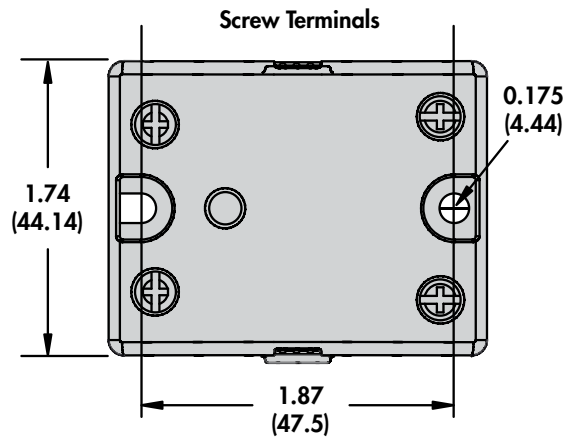
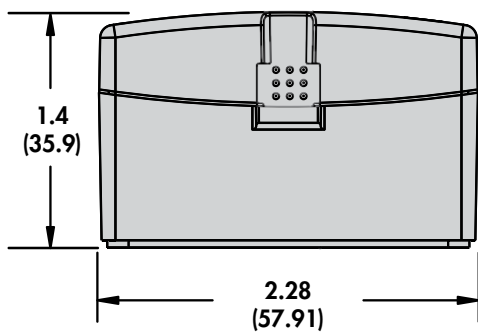
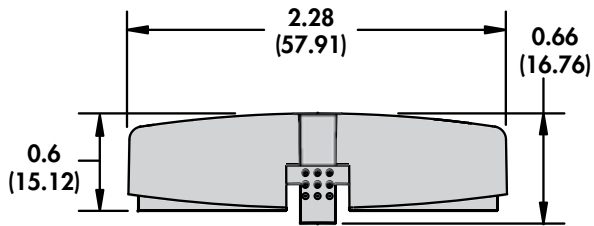

SECTION 4

Heat Sink/Class 6 SSR Relay

Thermal management is a fundamental consideration in the design and use of Solid State Relays (SSRs) because of the contact dissipation (typically 1 W per amp). It is, therefore, vital that sufficient heat sinking is provided, or the life and switching reliability of the SSR will be compromised. The unique design of the Magnecraft aluminum heat sink maximizes heat dissipation. This heat sink is available for Magnecraft's panel mount SSRs and ensures reliable operation when properly selected for the specific application. For ease of installation, all mounting holes are pre-drilled and tapped.

Optional Thermal Pad (SSR-TP-1)

See Section 3 p.21



Optional Heat Sink (SSR-HS-1)

See Section 3 p.20



User Guide:

The Magnecraft SSR should be firmly mounted on a clean, smooth heat sink surface using thermally conductive or suitable thermal transfer pads.

- The Magnecraft heat sink matches heat dissipation requirements for Magnecraft 6 Series SSRs; up to 50 amps.
- The Magnecraft heat sink design achieves outstanding thermal efficiency.
- The Magnecraft heat sink is pre-drilled and tapped to suit the Magnecraft SSR 6 Series "hockey puck style" range.

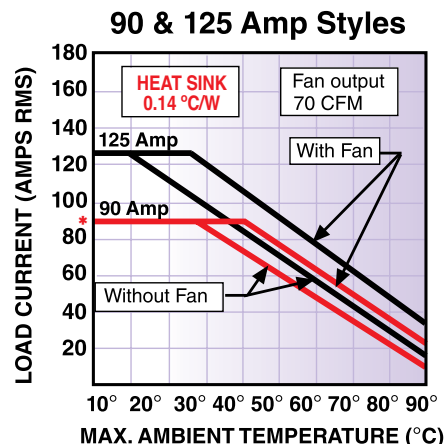
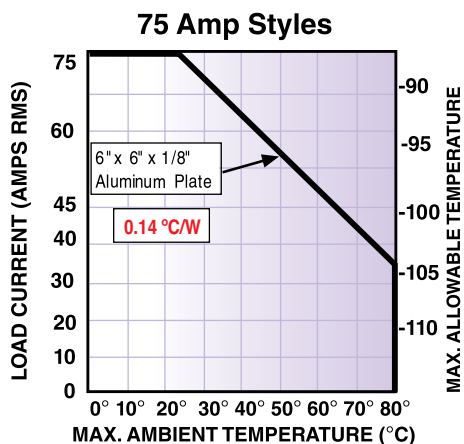
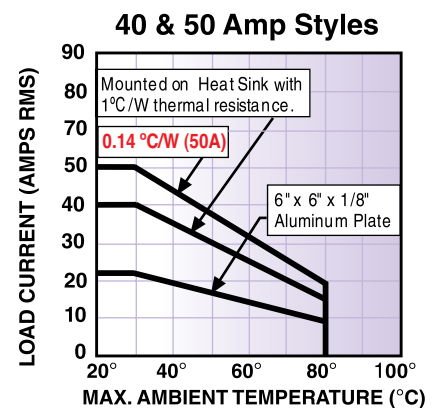
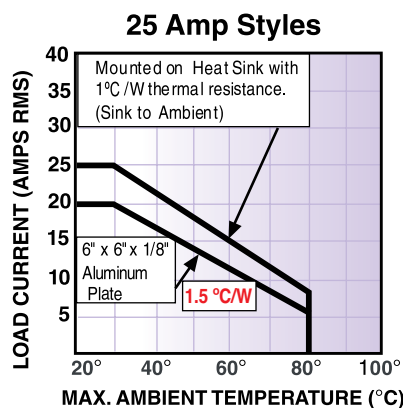
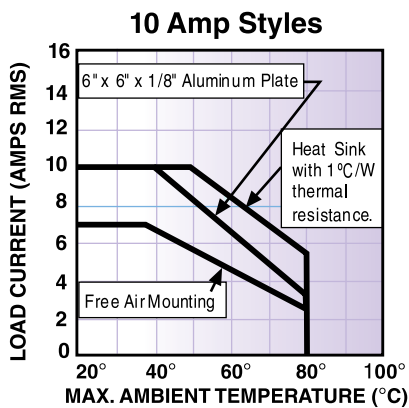

* De-rating curve without fan.

Class 6 Solid State Relays/SPST-NO, SPST-NC, DPST-NO, 10-125 Amp Rating *continued*



NEW
NEW
NEW
NEW
NEW

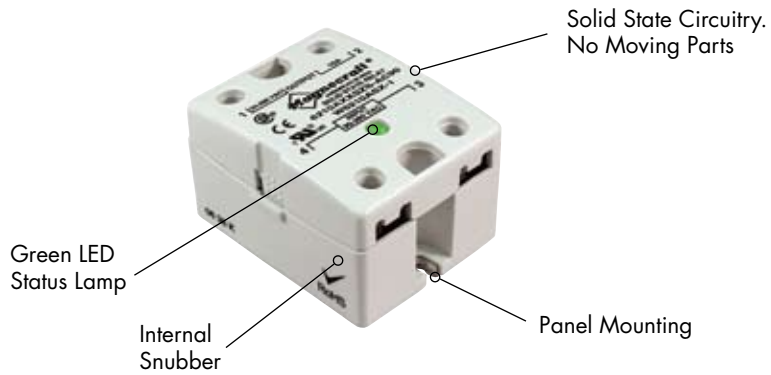

Standard Part Numbers

BOLD-FACED PART NUMBERS ARE NORMALLY STOCKED

AC Operated, DUAL MARKED		Input Voltage Range	Output Voltage Range	Contact Configuration	Switching Type	Rated Current Load (Amps)
New Part #	Supercedes		SCR Output			
6210AXXSZS-AC90	W6210ASX-1	90...280 VAC	24...280 VAC	SPST-NO	Zero Cross	10
6225AXXSZS-AC90	W6225ASX-1	90...280 VAC	24...280 VAC	SPST-NO	Zero Cross	25
6240AXXSZS-AC90	W6240ASX-1	90...280 VAC	24...280 VAC	SPST-NO	Zero Cross	40
6250AXXSZS-AC90**	W6250ASX-1	90...280 VAC	24...280 VAC	SPST-NO	Zero Cross	50
6275AXXSZS-AC90**	W6275ASX-1	90...280 VAC	24...280 VAC	SPST-NO	Zero Cross	75
6410AXXSZS-AC90	W6410ASX-1	90...280 VAC	48...480 VAC	SPST-NO	Zero Cross	10
6425AXXSZS-AC90	W6425ASX-1	90...280 VAC	48...480 VAC	SPST-NO	Zero Cross	25
6440AXXSZS-AC90	W6440ASX-1	90...280 VAC	48...480 VAC	SPST-NO	Zero Cross	40
6450AXXSZS-AC90**	W6450ASX-1	90...280 VAC	48...480 VAC	SPST-NO	Zero Cross	50
6475AXXSZS-AC90**	W6475ASX-1	90...280 VAC	48...480 VAC	SPST-NO	Zero Cross	75
6690AXXSZS-AC90**	W6690ASX-1	90...280 VAC	48...600 VAC	SPST-NO	Zero Cross	90
66125AXXSZS-AC90**	W66125ASX-1	90...280 VAC	48...600 VAC	SPST-NO	Zero Cross	125
DC Operated, DUAL MARKED						
New Part #	Supercedes					
6210AXXSZS-DC3	W6210DSX-1	3...32 VDC	24...280 VAC	SPST-NO	Zero Cross	10
6225AXXSZS-DC3	W6225DSX-1	3...32 VDC	24...280 VAC	SPST-NO	Zero Cross	25
6240AXXSZS-DC3	W6240DSX-1	3...32 VDC	24...280 VAC	SPST-NO	Zero Cross	40
6250AXXSZS-DC3**	W6250DSX-1	3...32 VDC	24...280 VAC	SPST-NO	Zero Cross	50
6275AXXSZS-DC3**	W6275DSX-1	3...32 VDC	24...280 VAC	SPST-NO	Zero Cross	75
6410AXXSZS-DC3	W6410DSX-1	3...32 VDC	48...480 VAC	SPST-NO	Zero Cross	10
6425AXXSZS-DC3	W6425DSX-1	3...32 VDC	48...480 VAC	SPST-NO	Zero Cross	25
6440AXXSZS-DC3	W6440DSX-1	3...32 VDC	48...480 VAC	SPST-NO	Zero Cross	40
6450AXXSZS-DC3**	W6450DSX-1	3...32 VDC	48...480 VAC	SPST-NO	Zero Cross	50
6475AXXSZS-DC3**	W6475DSX-1	3...32 VDC	48...480 VAC	SPST-NO	Zero Cross	75
6690AXXSZS-DC3**	W6690DSX-1	3...32 VDC	48...600 VAC	SPST-NO	Zero Cross	90
66125AXXSZS-DC3**	W66125DSX-1	3...32 VDC	48...600 VAC	SPST-NO	Zero Cross	125
DC Operated, DUAL MARKED						
New Part #	Supercedes		TRIAC Output			
6210AXXTZS-DC3	W6210DTX-1	3...32 VDC	24...280 VAC	SPST-NO	Zero Cross	10
6225AXXTZS-DC3	W6225DTX-1	3...32 VDC	24...280 VAC	SPST-NO	Zero Cross	25
6240AXXTZS-DC3	W6240DTX-1	3...32 VDC	24...280 VAC	SPST-NO	Zero Cross	40
6210BXXTZB-DC3	W6210DTX-3	3...32 VDC	24...280 VAC	DPST-NO	Zero Cross	10
6210XXATRS-DC3	W6210DTX-4	3...32 VDC	24...280 VAC	SPST-NC	Random	10
6225XXATRS-DC3	W6225DTX-4	3...32 VDC	24...280 VAC	SPST-NC	Random	25
6240XXATRS-DC3	W6240DTX-4	3...32 VDC	24...280 VAC	SPST-NC	Random	40
6410AXXTZS-DC3	W6410DTX-1	3...32 VDC	48...480 VAC	SPST-NO	Zero Cross	10
6425AXXTZS-DC3	W6425DTX-1	3...32 VDC	48...480 VAC	SPST-NO	Zero Cross	25
6440AXXTZS-DC3	W6440DTX-1	3...32 VDC	48...480 VAC	SPST-NO	Zero Cross	40
DC Operated, DUAL MARKED						
New Part #	Supercedes		MOSFET Output			
6312AXXMDS-DC3	W6212DDX-1	3...32 VDC	3...200 VDC	SPST-NO	Random	12
6325AXXMDS-DC3**	W6225DDX-1	3...32 VDC	3...200 VDC	SPST-NO	Random	25
6340AXXMDS-DC3**	W6240DDX-1	3...32 VDC	3...200 VDC	SPST-NO	Random	40

**Only Legacy (superceding) part is currently available.

SECTION 4



**Thermal Pad
(SSR-TP-1)**
Section 3 p.21



**Blade Terminals
DPST-NO**



**Heat Sink
(SSR-HS-1)**
Section 3 p.20

Available Part Numbers (Non-Standard)

AC Operated (SCR Output)	DC Operated (SCR Output)	DC Operated (Triac Output)	DC Operated (MOSFET Output)
6210AXXSRS-AC90	6210AXXSRS-DC3	6210AXXTRS-DC3	6312AXXMDB-DC3
6210XXASRS-AC90	6210XXASRS-DC3	6210BXXTZB-DC3	6312AXXMDS-DC20
6225AXXSZS-AC90	6210AXXSZS-DC20	6225AXXTRS-DC3	6325BXXMDS-DC3
6225AXXSRS-AC90	6225AXXSRS-DC3	6225BXXTZB-DC3	6340BXXMDS-DC3
6225XXASRS-AC90	6225XXASRS-DC3	6225XXATRB-DC3	
6225AXXSZS-AC18	6225BXXSZB-DC4	6240AXXTZS-DC3	
6225BXXSZB-AC90	6225BXXSZB-DC3	6425AXXTZB-DC3	
6240AXXSRS-AC90	6225BXXSRB-DC4	6425BXXTZB-DC3	
6240XXASRS-AC90	6240AXXSRS-DC3	6440AXXTZB-DC3	
6240AXXSZS-AC18	6240XXASRS-DC3	6440BXXTZB-DC3	
6240BXXSZB-AC90	6240AXXSZB-DC3		
6250XXASRS-AC90	6240BXXSZB-DC4		
6250AXXSZS-AC18	6240BXXSZB-DC3		
6425BXXSZB-AC90	6240BXXSRB-DC4		
6440XXASRS-AC90	6250AXXSRS-DC3		
6440BXXSZB-AC90	6250XXASRS-DC3		
64125XXASRS-AC90	6425BXXSZB-DC3		
	6440BXXSZB-DC3		
	6450AXXSRS-DC3		
	6490AXXSRS-DC3		
	6650AXXSRS-DC3		
	6690AXXSRS-DC3		
	66125AXXSRS-DC3		

Part Number Builder

Series	Output Voltage	Output Current	Contact Config.	Output Type	Turn On Type	Connection Type	-	Input Voltage
6	1 = 2 to 60 VDC	07 = 7 AMPS	AXX = SPST-NO	S = SCR	Z = ZERO CROSS	S = SCREW TERMINALS		AC90 = 90 - 280 VAC
	2 = 24 to 280 VAC	10 = 10 AMPS	XXA = SPST-NC	T = STANDARD TRIAC	R = RANDOM	B = BLADE TERMINALS		AC18 = 18 - 28 VAC
	3 = 3 to 200 VDC	12 = 12 AMPS	BXX = DPST-NO	M = MOSFET	D = DC SWITCH			DC3 = 3 - 32 VDC
	4 = 48 to 480 VAC	25 = 25 AMPS	XXB = DPST-NC					DC4 = 4 - 15 VDC
	6 = 48 to 600 VAC	40 = 40 AMPS						DC20 = 20 - 50 VDC
		50 = 50 AMPS						
		75 = 75 AMPS						
		90 = 90 AMPS						
		100 = 100 AMPS						
		125 = 125 AMPS						

Note - Not all iterations of option codes are available.