

# Keyat

RS232/485  
Keyboard  
Port Adapter  
(Version 2.0J and above)

*Copyright 1996-2000*  
**L3 Systems, Inc.**  
**Redmond, WA**

---

# Quick Reference

Description	Cmd	Notes
ASCII transfer*	~A	Negates binary transfer (~B)
Binary transfer	~B	Use only with ~K or ~S
Set to character mode*	~C	Send ASCII chars
ASCII hex mode	~H	Send Hex ASCII chars
Keyboard code mode	~K	Send direct key codes
DOS scan code mode	~S	Send DOS scan codes
Reset/Enable Commands	~~~~~ ~~~	10 ~ does reset if commands on, if not, it enables commands
Turn off Commands	~@	Turn off commands (~anything)
Send scan code	~:nn	Sends scan code nn
Scan code Key down	~+nn	Sends key down, scan code nn
Scan code key up	~-nn	Sends key up, scan code nn
Immediate turn around	~I	Data interpreted as received, non-addressed mode only
Line turn around*	~L	Data buffered until enter or <CR>
Monitor ON	~M	Monitor keyboard, key codes
Qwerty Monitor ON	~Q	Monitor keyboard, ASCII
Monitor off*	~N	Turn off keyboard monitoring
Display ON/OFF LEDs	~Dnn	Sets keyboard LED status to nn
Transfer to keyboard	~Xnn	Sends nn to keyboard
Status request	~?	Response = AA- EELLDBTM
Sleep	~Znn	Sleeps nn seconds
Set turnaround delay	~Pnn	Sets turnaround to nn milli-sec
Send CR mode	~F	Sends <CR> through
Re-assign ASCII code	~Gaaxx	Sets char aa to use scan code xx
Re-map ASCII Chars	~Raa112 2b1122	Re-maps ASCII characters aa and bb as 1122
**Test Mode	~T	Keyat test
EEPROM Read	~ERnn	Read EEPROM string #nn
EEPROM Write	~EWnn	Write EEPROM string #nn
EEPROM Execute	~EEnn	Execute EEPROM string #nn

\*default setting \*\*Available only with Keyat-2 with EEPROM

NOTE: LED Solid=Keyboard activity, Blinking=RS-232/485 Activity

## Contents

---

<b>Introduction</b>	<b>1</b>
<b>Connections</b>	<b>2</b>
<b>LED Status</b>	<b>2</b>
<b>Jumpers &amp; Switches</b>	<b>3</b>
K1 Keyboard Jumper	3
K2 RS232/485 Jumper	3
DIN Connector Pin out	3
DIP Switch Settings	4
<b>Sending Data</b>	<b>5</b>
<b>Commands</b>	<b>5</b>
Data Mode Commands	6
Send a Scan Code	7
Up/Down Scan Codes	7
Transfer Setting	7
Turn Around Setting	8
Keyboard Monitor	8
Status Request	9
Keyboard Commands	9
Test Keyat	9
Sleep	10
EEPROM Commands	10
Chaining	11
Autoexec	11
Special Characters	12
Examples	12
<b>Serial Port Operation</b>	<b>13</b>
Serial Port Connector	13
Multi-drop Connection	14
RS485 Wiring	14
<b>Scan Codes</b>	<b>15</b>
<b>ASCII Scan Codes</b>	<b>18</b>
<b>Warranty</b>	<b>23</b>

### **Warning**

Improper grounding can cause damage to equipment!!! Before connecting two computers, make sure that they share a common system ground and always stay connected to the same ground during the use of the Keyat Keyboard Port Adapter. If you are anyway unsure that two computers share the same ground, do not connect them in any way using the Keyat Keyboard Port Adapter. L3 systems does not warranty damage to the Keyat Keyboard Port Adapter due to improper grounding, and does not warranty damage to connected equipment for any reason.

### **FCC Class B Approval Information**

NOTE: This equipment has been tested and found to comply with the limits for a class B digital device, pursuant to part 15 of the FCC Rules. These limits are designed to provide reasonable protection against harmful interference in a residential installation. This equipment generates, uses and can radiate radio frequency energy and, if not installed and used in accordance with the instructions, may cause harmful interference to radio communications. However, there is no guarantee that interference will not occur in a particular installation. If this equipment does cause interference to radio or television reception, which determined by turning the equipment off and on, the user is encouraged to correct the interference by one or more of the following measures:

- Reorient or relocate the receiving antennae
- Increase the separation between the equipment and the receiver
- Connect the equipment into an outlet on a circuit different from that to which the receiver is connected
- Consult the dealer or an experienced radio/TV technician for help

## Introduction

The Keyat keyboard port adapter allows key codes to be sent to a computer or received from the keyboard by translating RS-232 or RS-485 signals to/from keyboard interface signals. Typical uses for the Keyat Keyboard Port Adapter are:

- **Testing software** - With the help of a Keyat, you can develop a sequence of keys and send them to the keyboard port of a computer running the software that you want to test. You can do this without having to add any software or ports to the computer system you are testing.
- **Multi-system testing** - Using the multi-drop capability of the Keyat keyboard port adapter allows centrally controlled testing of up to 58 systems simultaneously. Only the Keyat port adapter allows such flexibility.
- **Remote Access** - The Keyat keyboard port adapter allows remote access to a system where the software does not provide any other method.
- **Monitoring Keyboard sessions** - The Keyat can be used to monitor keyboard sessions. This can be helpful to develop regression test data or to detect keystrokes that are causing problems with target software.
- **Serial Keyboard** - Attach a Keyboard to your Computer's RS-232 Port - You can use the Keyat to send and receive from a Keyboard attached to an RS-232 port.
- **Attaching input devices** – Allows you to attach RS-232/RS-485 devices to the keyboard port such as bar code readers, scales, and credit card readers.

## Connections

The following illustrates a typical connection of the Keyat.

1. The keyboard plugs into the 5 pin DIN keyboard connector. Use a PS/2 adapter (6-pin mini-DIN female to 5-pin DIN male) for PS/2 style connectors.
2. A 5 PIN male-to-male DIN cable is supplied to connect the Keyat to the computer. Use a PS/2 adapter (5-pin DIN female to 6-pin mini-DIN male) for PS/2 style motherboard connections.
3. The Serial port connects the same as a modem if using the RS-232 interface. See the **Serial Port Operation** section for more details.

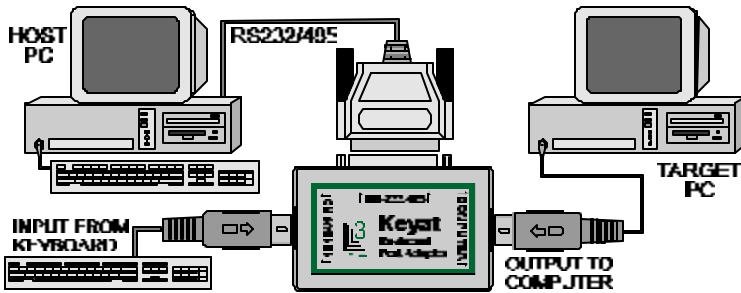

When a keystroke is received from the keyboard, the RS232/485 port is blocked. Likewise, when an RS232 command is received, the keyboard is blocked. Note: simultaneous use in any configuration is discouraged.

## LED Status

A red status indicator located next to the computer port indicates port activity. It turns solid red when the attached keyboard port is being used. It blinks whenever the RS-232/485 port is active. If a non-zero address is set, the LED blinks only when selected.

## Jumpers and Switches

### K1 - Keyboard Jumper

K1 connects the keyboard and the PC to the Keyat logic. The default jumper positions are the only ones recommended.

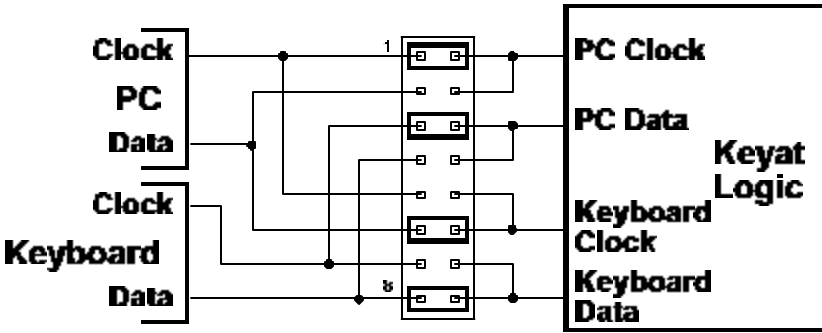

### K2 - RS232/RS485 Jumper

K2 Selects between an RS232 and an RS485 interface.

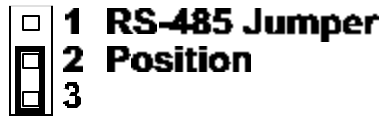
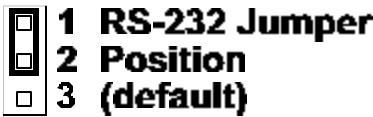

## Keyat Keyboard & PC DIN Connector

The following connector shows the pin definitions for the two 5 pin DIN connectors. If the application is for an RS-232 keyboard, the computer DIN connector can be used to provide 5 volts power.

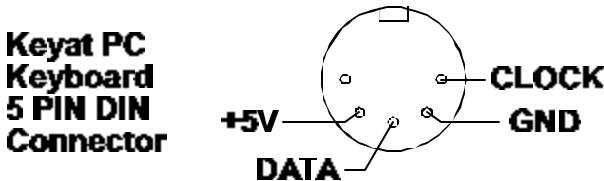

## SWA - DIP SWITCH Settings

Positions 1-6, Address Select C=Closed, O=Open

ADDR	1	2	3	4	5	6	ADDR	1	2	3	4	5	6
NONE	O	O	O	O	O	O	31	C	C	C	C	C	O
1	C	O	O	O	O	O	32	O	O	O	O	O	C
2	O	C	O	O	O	O	33	C	O	O	O	O	C
3	C	C	O	O	O	O	34	O	C	O	O	O	C
4	O	O	C	O	O	O	35	C	C	O	O	O	C
5	C	O	C	O	O	O	36	O	O	C	O	O	C
6	O	C	C	O	O	O	37	C	O	C	O	O	C
7	C	C	C	O	O	O	38	O	C	C	O	O	C
8	O	O	O	C	O	O	39	C	C	C	O	O	C
9	C	O	O	C	O	O	40	O	O	O	C	O	C
10	O	C	O	C	O	O	41	C	O	O	C	O	C
11	C	C	O	C	O	O	42	O	C	O	C	O	C
12	O	O	C	C	O	O	43	C	C	O	C	O	C
13	C	O	C	C	O	O	44	O	O	C	C	O	C
14	O	C	C	C	O	O	45	C	O	C	C	O	C
15	C	C	C	C	O	O	46	O	C	C	C	O	C
16	O	O	O	O	C	O	47	C	C	C	C	O	C
17	C	O	O	O	C	O	48	O	O	O	O	C	C
18	O	C	O	O	C	O	49	C	O	O	O	C	C
19	C	C	O	O	C	O	50	O	C	O	O	C	C
20	O	O	C	O	C	O	51	C	C	O	O	C	C
21	C	O	C	O	C	O	52	O	O	C	O	C	C
22	O	C	C	O	C	O	53	C	O	C	O	C	C
23	C	C	C	O	C	O	54	O	C	C	O	C	C
24	O	O	O	C	C	O	55	C	C	C	O	C	C
25	C	O	O	C	C	O	56	O	O	O	C	C	C
26	O	C	O	C	C	O	57	C	O	O	C	C	C
27	C	C	O	C	C	O	58	O	C	O	C	C	C
28	O	O	C	C	C	O	*59	C	C	O	C	C	C
29	C	O	C	C	C	O	**60	O	O	C	C	C	C
30	O	C	C	C	C	O	***61	C	O	C	C	C	C

\* Special setting, for Immediate Mode, address 0

\*\* Special Setting, for Qwerty Monitor Mode (~Q), address 0

\*\*\* Special Setting, for Monitor Mode (~M), address 0

## Positions 7-8, Baud Rate

BAUD Rate	7	8
9600	O	O
4800	C	O
2400	O	C
1200	C	C

## Sending Data

The main job of a Keyat is to transfer data from the RS-232 or RS-485 port and send it through to the computer's keyboard port. Data can be sent using ASCII, ASCII control codes, DOS scan codes, keyboard scan codes or ASCII hex. If you are using line turn around mode or if the Keyat is addressed, a line can have a maximum length of 46 characters and should end with an <ENTER> (CR, hex 0D). When using immediate mode, data and commands are interpreted as received, and buffered up to 46 characters. If you get more than 46 characters ahead of the computer, the additional characters will be ignored. Characters are not echoed when the Keyat is addressed.

If the Keyat is addressed, a colon is sent back immediately to acknowledge that the data was received. If the Keyat is not addressed and in line turn mode, a colon is sent back after the data has been processed, signaling that another command can be sent. The following example shows the ASCII characters 'DIR<ENTER>' being sent through the Keyat.

Example: Keyat 2.0x, Copyright L3 Systems, 1996-99  
:DIR^M<ENTER>  
:

## Commands

Commands are instructions to the Keyat to do something other than just pass data through to the computer. All commands begin with a ~ (tilde, hex 7E) character followed by a command character and then in some cases some data.

~@ **Disable Commands** – All commands are disabled until 10 consecutive tildes (~~~~~~) or reset/power cycle.

~~~~~ **Reset/Enable Commands** – If commands are disabled, this will enable commands. If commands are enabled, this will reset the Keyat (& run power-up string if loaded).

## Data Mode Commands

The four mode commands set the way data is interpreted by the Keyat. A mode is set until another mode is given or until a power failure occurs.

**~C Character Mode** - is the default mode of operation. When this mode is set, any ASCII character except ~ (tilde, hex 7E), ^ (caret, hex 5E), and CR (return, hex 0D) is converted to the scan codes for that character. Each ASCII character will be sent to the keyboard with the corresponding “make” and “release” codes. Allow enough time for the codes to be sent through to the computer, as an ASCII code can require up to 10 keyboard codes to execute.

Control codes may be sent by a combination of a ^ (caret, hex 5E), and the corresponding letter. For example, a control C (Hex 03) is ^C.

**~H Hex ASCII Mode** - Data is interpreted as hexadecimal encoded ASCII. For example, to send the computer the character 'A', you would need to send its hexadecimal ASCII value (Hex 41) as two ASCII digits, 4 and 1.

**~S Scan Code Mode** - In this mode, data is translated to the corresponding keyboard scan codes. For an ASCII transfer, each pair of ASCII encoded characters is interpreted as a DOS scan code. For a binary transfer, each 8-bit character is interpreted as a DOS scan code. DOS assigns each key a DOS scan code. Note that all DOS scan codes are sent complete with make and break sequences.

**~K Key Code Mode** - In this mode, codes are sent directly to the computer without interpretation. For an ASCII transfer, each pair of ASCII encoded characters are interpreted as one keyboard code. For a binary transfer, each 8-bit character is interpreted as a keyboard code. Care should be taken in using keyboard scan codes, as the computer can be left in a very confused state if the scan code sequence is not properly completed

## Send a scan code

If you want to send a scan code without going into scan code mode, then use the `~:nn` command. This is useful for the occasional function key, arrow key or any other keys that doesn't have an ASCII equivalent. See the scan code table later on for a list of valid scan codes.

**~:nn Send Scan Code** – This scan code nn.

**Example:** `~:~:73<ENTER>` (*sends PgUp*)

## Up/Down Scan Codes

Use these two commands to send a key down or a key up to the computer. A common use is for Shift, Alt and Cntl keys, which vary the meaning of successive scan codes. See the scan code table later on for a list of valid scan codes.

**~+nn Key down Scan Code** – This sends just the key down (make) sequence for scan code nn.

**~-nn Key up Scan Code** – This sends just the key up (make) sequence for scan code nn.

**Example:**

`~:+56~:~:62~-56<ENTER>` (*sends <Alt>F4*)

where: **~+56** Sends Alt down sequence

**~:62** Sends F4 scan code

**~-56** Sends Alt up sequence

## Transfer setting

There are two transfer settings, ASCII and binary. The binary transfer setting applies only to scan code mode (`~S`) and key code mode (`~B`). The setting is persistent until the next `~A` or `~B` command or until power is cycled.

**~A ASCII Transfer** - This is the default setting. If ASCII transfer is set, all data is interpreted as ASCII.

**~B Binary Transfer** - In scan code or key code modes. data is sent as 8 bit binary.

## Turn around setting

Data can be sent and interpreted one line at a time, or be processed immediately. The default setting is for line turn around mode (~L). This is better for automated control and provides more reliable interaction. Immediate turn around mode (~I) can better simulate keyboard operation. The setting persists until the next ~I or ~L command, or until power is cycled.

- ~L Line Turn Around** - Set to a line oriented basis, each line must end with an <ENTER> or <CR>, hex 0D.
- ~F Send <CR> mode** - This will cause the <CR> to be sent on to the computer as an <ENTER> key. The ~C command clears this condition.
- ~I Immediate Turn-around** - Data is interpreted 'on-the-fly'. Note that in this mode <ENTER> or <CR> (Hex 0D) is not a special character, and passed on to the computer. XON/XOFF flow control is provided. However, caution should be exercised, as it is easy to overrun the PC's keyboard receive buffer.
- ~Pnn Set Turn Around Delay (nn milliseconds)** - This sets the delay that the Keyat waits before responding to a command. The default setting in non-addressed mode is 0, and in addressed mode the default setting is 3 milliseconds. (Note: you must send two digits. For 7 milliseconds, send ~P07.)

## Keyboard Monitor

The Keyat can send either binary key codes (~M) or ASCII translations (~Q) of keys struck at the local keyboard through to the RS-232/RS-485 port. The QWERTY monitor can be used for constructing an RS-232 or RS485 keyboard, and it will send only keys with ASCII translations.

- ~M Monitor ON** - Monitor Key Scan codes.
- ~Q QWERTY Monitor ON** - Monitor ASCII translation  
(Note: Address 60, turns this mode on at address 0.)
- ~N Monitor OFF** - Turn keyboard monitor off (default).



## Sleep

**~Znn Sleep** – Use sleep to provide delays. The value nn is in seconds (approximate). This can be helpful when doing scripting, allowing the Keyat to help you pace keystrokes, to avoid out-running the application. :

\*~Z15<ENTER> (*delays 15 seconds*)

## EEPROM Commands

The onboard EEPROM (available only on the Keyat-2) provides memory to store strings of keys and or commands that can be later executed. The EEPROM consists of a set of 8 strings, 31 characters in length, numbered 0 to 7. EEPROM commands are special commands, with the following restrictions:

- Use EEPROM commands in “Line turn-around” only (~L). Only use one EEPROM command per line.
- Make sure that the EEPROM command is the last command in the line. All other characters or commands on the line after an EEPROM command will be ignored.
- Do not use the EEPROM read command (~ERnn) in addressed mode.

**~ERnn Read EEPROM** – Read string up to 31 characters to EEPROM, string number nn.

**~EWnn Write EEPROM** - Write string up to 31 characters to EEPROM, string number nn

**~EEnn Write EEPROM** - Execute string number nn.

Example:

: ~EW01DIR^M<ENTER> (*Loads string 01*)

: ~ER01<ENTER>DIR^M (*Displays string 01*)

: ~EE01<ENTER> (*Executes string 01*)

:

## Chaining Strings

EEPROM strings may be 'chained' for longer key sequences. To do this, put the (~EEnn) for the next string. Be careful not to generate an unending loop using this feature. The following example shows a string with a DIR command chained to another string with a 3 second delay and then the VER command. These two commands could both be in one string, but have been separated to simply illustrate the chain feature.

Example:

```
: ~EW01DIR^M~EE02<ENTER>    (Loads string 01)
: ~EW02~Z03VER^M<ENTER>    (Loads string 02)
: ~EE01<ENTER>    (Executes string 01 & string 2)
:
```

## AUTOEXEC String

The EEPROM string 00 is special string that can be executed when the keyboard receives a reset from the PC. This reset generally occurs when the system is re-booted, so it can be used to initialize the PC and/or initialize the Keyat. To be recognized as a autoexec boot string, the string must begin with a ~Znn command. If commands are to be sent to the PC, make sure that the ~Znn delay is longer than the time it takes to boot the operating system. If booting is especially long, multiple ~Znn commands can be used.

The following shows an autoexec string that allows 30 seconds to boot, sets the Keyat turn-around delay to 50 milliseconds, and executes a command on the PC named "INIT".

Example:

```
: ~EW00~Z30~P50INIT^M<ENTER>    (Loads string 00)
: ~ER00<ENTER>~Z30~P50INIT^M    (Displays string 01)
:
```

## POWER-UP String

The EEPROM string 01 is special string that can be executed after the Keyat receives powers or is reset. This is generally used to initialize the Keyat. To be recognized as a power-up string, it must begin with a ~Znn command.

Examples:

- : ~EW01~Z01~I~@ (Delay 1 seconds, Put in Immediate and disable commands)
- : ~ER01~Z02~P05~S^M (Delay 2 seconds, Set turn-around=5 ms, Scan code mode )

## Re-map ASCII Characters

**~Raaxxybbxyy Re-map ASCII Chars** – Allows you to Re-map one or two ASCII characters. All data is entered as HEX encoded ASCII. **Important: This command has a fixed format, and cannot be used in immediate mode.** Put zeros in for the second character if only one character is to be re-mapped. To ignore a character, put all zeros for the map data. To clear the table, enter all zeros after the R.

Examples:

- : ~R414200454647<ENTER> (Re-map A to B, E to FG)
- : ~R0D0A0D1C0000<ENTER> (Re-map CR, hex 0D to CR and LF, Hex 0A, and ignore ESC, hex 1C )
- : ~R0000000000000<ENTER> (Erase re-map table)

## Assign scan code

**~Gaaxx Assign Scan Code** – Allows you to assign a DOS scan code to be sent to the computer when receiving a particular ASCII character.

Example: : ~G0DA0<ENTER> (Assigns the keypad enter key to the ASCII <CR> character)

## Special Characters

ASCII Hex (~nn) - ASCII hex characters can be sent by sending the hex code preceded by a ~ (tilde, hex 7E). For example, to send an M character in hex, send a ~4D.

Tilde and Caret Characters (~ ~ ^ ^) - To send a ~ (tilde, hex 7E) or ^ (caret, hex 5E) character, send the character twice. For example a ~ ~ will send the key codes for the ASCII character ~.

## Examples:

### Simple Poll:

```
:~?00-0002CALN      Status poll and response  
:                      addr=0, no errors, numlock=on,  
                      char mode, ASCII transfer,  
                      Line turn around, monitor=OFF
```

### Use of different data modes:

```
:~C<ENTER>          Sets to character mode  
:DIR^M<ENTER>       Sends DOS a directory command  
:~H<ENTER>          Sets to ASCII HEX mode  
:4449520D<ENTER>    Sends DOS a directory command  
:~S<ENTER>          Sets to scan code mode  
:32231928<ENTER>    Sends DOS a directory command  
:~K<ENTER>          Sets to key code mode  
:23F02343F0432DF02D5AF05A<ENTER>  
                      Sends DOS a directory command
```

### Autoexec Command for Win'95 (uses boot sense) :

```
:~EW00~Z99~:28~Z30~+56~:63~-56<ENTER>  
                      On boot, waits 99 seconds for boot to finish,  
                      sends a <ENTER> (Win 95 Network logon), waits  
                      another 30 seconds, and sends an Alt-F5. The  
                      Alt-F5 would be assigned as a key shortcut for a  
                      desktop application that you wish to run.
```

## Serial Port Operation

The Serial Port operation is configured by the DIP switch for baud rates of 1200, 2400, 4800 or 9600 baud. The asynchronous character frame is configured for 1 start bit, 8 data bits, one stop bit. The port is configured as a DCE device (it connects to a computer like a modem). On the 25 pin DB-25S connector, it transmits data on pin 3 and receives data on pin 2. No other RS-232 signal is required for it to operate.

## **Serial Port Connector**

In single drop (not addressed) mode, pins 6 and 8 will always be active. In multi-drop mode, they are only active when the Keyat is not transmitting.

| Pin | Signal        | Function             |
|-----|---------------|----------------------|
| 1   | Chassis Gnd   |                      |
| 2   | TX to Keyat   | RS232 Input          |
| 3   | RX from Keyat | RS232 Output         |
| 4   | RTS           | Connected to CTS     |
| 5   | CTS           | Connected to RTS     |
| 6   | DSR           | RS232 Output         |
| 7   | Signal Gnd    | RS232 Output         |
| 8   | DCD           | RS232 Output         |
| 20  | DTR           | RS232 Input          |
| 14  | Rx/Tx+        | RS485 Input / Output |
| 16  | Rx/Tx-        | RS485 Input / Output |

### Multi Drop Operation

If the DIP switch address setting is not zero, Keyat looks for an address select prefix to any buffer received. The address must be the first byte of the transmission and the high bit set. Address 1 is hex 81, Address 2 is hex 82. If you send a command to address 80, all Keyats will read it.

When sending data to the Keyat in multi-drop mode, the Keyat will send a single byte colon character when the message is received. This does not mean that another buffer can be sent! The Keyat sends the colon character to signify that the message was received and that the host can go on to talk to other devices. If a proper delay cannot be assured, it is recommended that you poll the device until it responds before sending another buffer.

### RS485 Wiring

If you are using RS485 connections to the Keyat, be careful that all devices be referenced to the same ground. **Improper grounding can cause damage to the circuitry**, and will not allow the transmitter to operate.

## Scan Codes

Below is the table of Scan definitions.

| AT SCAN CODE | KEYAT SCAN CODE | KEY          | KEYBOARD SCAN CODES     |
|--------------|-----------------|--------------|-------------------------|
| 01           | 01              | ESC          | 76 F0 76                |
| 02           | 02              | 1 / !        | 16 F0 16                |
| 03           | 03              | 2 / @        | 1E F0 1E                |
| 04           | 04              | 3 / #        | 26 F0 26                |
| 05           | 05              | 4 / \$       | 25 F0 25                |
| 06           | 06              | 5 / %        | 2E F0 2E                |
| 07           | 07              | 6 / ^        | 36 F0 36                |
| 08           | 08              | 7 / &        | 3D F0 3D                |
| 09           | 09              | 8 / *        | 3E F0 3E                |
| 10           | 10              | 9 / (        | 46 F0 46                |
| 11           | 11              | 0 / )        | 45 F0 45                |
| 12           | 12              | - / _        | 4E F0 4E                |
| 13           | 13              | = / +        | 55 F0 55                |
| 14           | 14              | Backspace    | 66 F0 66                |
| 15           | 15              | Tab          | 0D F0 0D                |
| 16           | 16              | Q            | 15 F0 15                |
| 17           | 17              | W            | 1D F0 1D                |
| 18           | 18              | E            | 24 F0 24                |
| 19           | 19              | R            | 2D F0 2D                |
| 20           | 20              | T            | 2C F0 2C                |
| 21           | 21              | Y            | 35 F0 35                |
| 22           | 22              | U            | 3C F0 3C                |
| 23           | 23              | I            | 43 F0 43                |
| 24           | 24              | O            | 44 F0 44                |
| 25           | 25              | P            | 4D F0 4D                |
| 26           | 26              | [ / {        | 54 F0 54                |
| 27           | 27              | ] / }        | 5B F0 5B                |
| 28           | 28              | Enter        | 5A F0 5A                |
| 28           | A0              | Keypad Enter | E0 5A E0 F0 5A          |
| 29           | 29              | Left Ctrl    | 14 F0 14                |
| 29           | A1              | Right Ctrl   | E0 14 E0 F0 14          |
| 29+69        | A2              | PAUSE        | E1 14 77 E1 F0 14 F0 77 |
| 30           | 30              | A            | 1C F0 1C                |
| 31           | 31              | S            | 1B F0 1B                |

## Scan Codes (cont.)

| AT SCAN CODE | KEYAT SCAN CODE | KEY         | KEYBOARD SCAN CODES           |
|--------------|-----------------|-------------|-------------------------------|
| 32           | 32              | D           | 23 F0 23                      |
| 33           | 33              | F           | 2B F0 2B                      |
| 34           | 34              | G           | 34 F0 34                      |
| 35           | 35              | H           | 33 F0 33                      |
| 36           | 36              | J           | 3B F0 3B                      |
| 37           | 37              | K           | 42 F0 42                      |
| 38           | 38              | L           | 4B F0 4B                      |
| 39           | 39              | ;/:         | 4C F0 4C                      |
| 40           | 40              | '/"         | 52 F0 52                      |
| 41           | 41              | `/~         | 0E F0 0E                      |
| 42           | 42              | Left Shift  | 12 F0 12                      |
| 43           | 43              | \           | 5D F0 5D                      |
| 44           | 44              | Z           | 1A F0 1A                      |
| 45           | 45              | X           | 22 F0 22                      |
| 46           | 46              | C           | 21 F0 21                      |
| 47           | 47              | V           | 2A F0 2A                      |
| 48           | 48              | B           | 32 F0 32                      |
| 49           | 49              | N           | 31 F0 31                      |
| 50           | 50              | M           | 3A F0 3A                      |
| 51           | 51              | ,/<         | 41 F0 41                      |
| 52           | 52              | ./>         | 49 F0 49                      |
| 53           | 53              | //?         | 4A F0 4A                      |
| 53           | 93              | /           | E0 4A E0 F0 4A                |
| 54           | 54              | Right Shift | 59 F0 59                      |
| 55           | 55              | *           | 7C F0 7C                      |
| 55           | A4              | PRT SCRN    | E0 12 E0 7C E0 F0 7C E0 F0 12 |
| 56           | 56              | Left Alt    | 11 F0 11                      |
| 56           | A5              | Right Alt   | E0 11 E0 F0 11                |
| 57           | 57              | Space       | 29 F0 29                      |
| 58           | 58              | Caps Lock   | 58 F0 58                      |
| 59           | 59              | F1          | 05 F0 05                      |
| 60           | 60              | F2          | 06 F0 06                      |
| 61           | 61              | F3          | 04 F0 04                      |
| 62           | 62              | F4          | 0C F0 0C                      |
| 63           | 63              | F5          | 03 F0 03                      |
| 64           | 64              | F6          | 0B F0 0B                      |
| 65           | 65              | F7          | 83 F0 83                      |

## Scan Codes (cont.)

| AT SCAN CODE | KEYAT SCAN CODE | KEY                   | KEYBOARD SCAN CODES           |
|--------------|-----------------|-----------------------|-------------------------------|
| 66           | 66              | F8                    | 0A F0 0A                      |
| 67           | 67              | F9                    | 01 F0 01                      |
| 68           | 68              | F10                   | 09 F0 09                      |
| 69           | 69              | NUM LOCK              | 77 F0 77                      |
| 70           | 70              | SCROLL LOCK           | 7E F0 7E                      |
| 71           | 71              | Home                  | E0 6C E0 F0 6C                |
| 71           | A6              | Keypad Home / 7       | 6C F0 6C                      |
| 72           | 72              | Up Arrow              | E0 12 E0 75 E0 F0 75 E0 F0 12 |
| 72           | A7              | Keypad Up Arrow / 8   | 75 F0 75                      |
| 73           | 73              | Page Up               | E0 7D E0 F0 7D                |
| 73           | A8              | Keypad PageUp / 9     | 7D F0 7D                      |
| 74           | 74              | -                     | 7B F0 7B                      |
| 75           | 75              | Left Arrow            | E0 12 E0 6B E0 F0 6B E0 F0 12 |
| 75           | A9              | Keypad Left Arrow / 4 | 6B F0 6B                      |
| 76           | 76              | 5                     | 73 F0 73                      |
| 77           | 77              | Rt Arrow              | E0 12 E0 74 E0 F0 74 E0 F0 12 |
| 77           | B0              | Keypad Rt Arrow / 6   | 74 F0 74                      |
| 78           | 78              | +                     | 79 F0 79                      |
| 79           | 79              | End                   | E0 12 E0 69 E0 F0 69 E0 F0 12 |
| 79           | B1              | End/1                 | 69 F0 69                      |
| 80           | 80              | Down Arrow            | E0 12 E0 72 E0 F0 72 E0 F0 12 |
| 80           | B2              | Keypad Dn Arrow / 2   | 72 F0 72                      |
| 81           | 81              | Page Down             | E0 12 E0 7A E0 F0 7A E0 F0 12 |
| 81           | B3              | Keypad PgDn / 3       | 7A F0 7A                      |
| 82           | 82              | Insert                | E0 70 E0 F0 70                |
| 82           | B4              | Ins/0                 | 70 F0 70                      |
| 83           | 83              | Delete                | E0 12 E0 71 E0 F0 71 E0 F0 12 |
| 83           | B5              | Keypad Del / .        | 71 F0 71                      |
| 84           |                 | Undefined             |                               |
| 85           |                 | Undefined             |                               |
| 86           |                 | Undefined             |                               |
| 87           | 87              | F11                   | 78 F0 78                      |
| 88           | 88              | F12                   | 07 F0 07                      |
| 89           |                 | Undefined             |                               |
| 90           | 90              | Left Window           | E0 1F E0 F0 1F                |
| 91           | 91              | Right Window          | E0 27 E0 F0 27                |
| 92           | 92              | Menu                  | E0 2F E0 F0 2F                |

## ASCII Scan Codes

Below is the table of ASCII scan code definitions.

| ASCII CHAR | ASCII HEX | KEYBOARD SCAN CODES        |
|------------|-----------|----------------------------|
| NUL ^@     | 00        | 14 1E F0 1E F0 14          |
| SOH ^A     | 01        | 14 1C F0 1C F0 14          |
| STX ^B     | 02        | 14 32 F0 32 F0 14          |
| ETX ^C     | 03        | 14 21 F0 21 F0 14          |
| EOT ^D     | 04        | 14 23 F0 23 F0 14          |
| ENQ ^E     | 05        | 14 24 F0 24 F0 14          |
| ACK ^F     | 06        | 14 2B F0 2B F0 14          |
| BEL ^G     | 07        | 14 34 F0 34 F0 14          |
| BS ^H      | 08        | 66 F0 66                   |
| TAB ^I     | 09        | 0D F0 0D                   |
| LF ^J      | 0A        | 14 3B F0 3B F0 14          |
| VT ^K      | 0B        | 14 42 F0 42 F0 14          |
| FF ^L      | 0C        | 14 4B F0 4B F0 14          |
| CR ^M      | 0D        | 3A F0 3A                   |
| SO ^N      | 0E        | 14 31 F0 31 F0 14          |
| SI ^O      | 0F        | 14 44 F0 44 F0 14          |
| DLE ^P     | 10        | 14 4D F0 4D F0 14          |
| DC1 ^Q     | 11        | 14 15 F0 15 F0 14          |
| DC2 ^R     | 12        | 14 2D F0 2D F0 14          |
| DC3 ^S     | 13        | 14 1B F0 1B F0 14          |
| DC4 ^T     | 14        | 14 2C F0 2C F0 14          |
| NAK ^U     | 15        | 14 3C F0 3C F0 14          |
| SYN ^V     | 16        | 14 2A F0 2A F0 14          |
| ETB ^W     | 17        | 14 1D F0 1D F0 14          |
| EM ^X      | 18        | 14 22 F0 22 F0 14          |
| SUB ^Y     | 19        | 14 35 F0 35 F0 14          |
| SUB ^Z     | 1A        | 14 1A F0 1A F0 14          |
| ESC ^[     | 1B        | 76 F0 76                   |
| FS ^\      | 1C        | 14 5D F0 5D F0 14          |
| GS ^]      | 1D        | 14 5B F0 5B F0 14          |
| RS ^^      | 1E        | 14 12 36 F0 36 F0 12 F0 14 |
| US ^_      | 1F        | 14 12 4E F0 4E F0 12 F0 14 |

## ASCII Scan Codes (cont.)

| ASCII CHAR | ASCII HEX | KEYBOARD SCAN CODES |
|------------|-----------|---------------------|
| Space      | 20        | 29 F0 29            |
| !          | 21        | 12 16 F0 16 F0 12   |
| "          | 22        | 12 52 F0 52 F0 12   |
| #          | 23        | 12 26 F0 26 F0 12   |
| \$         | 24        | 12 25 F0 25 F0 12   |
| %          | 25        | 12 2E F0 2E F0 12   |
| &          | 26        | 12 3D F0 3D F0 12   |
| '          | 27        | 52 F0 52            |
| (          | 28        | 12 46 F0 46 F0 12   |
| )          | 29        | 12 45 F0 45 F0 12   |
| *          | 2A        | 7C F0 7C            |
| +          | 2B        | 79 F0 79            |
| ,          | 2C        | 41 F0 41            |
| -          | 2D        | 7B F0 7B            |
| .          | 2E        | 49 F0 49            |
| /          | 2F        | 4A F0 4A            |
| 0          | 30        | 45 F0 45            |
| 1          | 31        | 16 F0 16            |
| 2          | 32        | 1E F0 1E            |
| 3          | 33        | 26 F0 26            |
| 4          | 34        | 25 F0 25            |
| 5          | 35        | 2E F0 2E            |
| 6          | 36        | 36 F0 36            |
| 7          | 37        | 3D F0 3D            |
| 8          | 38        | 3E F0 3E            |
| 9          | 39        | 46 F0 46            |
| :          | 3A        | 12 4C F0 4C F0 12   |
| ;          | 3B        | 4C F0 4C            |
| <          | 3C        | 12 41 F0 41 F0 12   |
| =          | 3D        | 12 55 F0 55 F0 12   |
| >          | 3E        | 12 49 F0 49 F0 12   |
| ?          | 3F        | 12 4A F0 4A F0 12   |

## ASCII Scan Codes (cont.)

| ASCII CHAR | ASCII HEX | KEY SCAN CODES    |
|------------|-----------|-------------------|
| @          | 40        | 12 1E F0 1E F0 12 |
| A          | 41        | 12 1C F0 1C F0 12 |
| B          | 42        | 12 32 F0 32 F0 12 |
| C          | 43        | 12 21 F0 21 F0 12 |
| D          | 44        | 12 23 F0 23 F0 12 |
| E          | 45        | 12 24 F0 24 F0 12 |
| F          | 46        | 12 2B F0 2B F0 12 |
| G          | 47        | 12 34 F0 34 F0 12 |
| H          | 48        | 12 33 F0 33 F0 12 |
| I          | 49        | 12 43 F0 43 F0 12 |
| J          | 4A        | 12 3B F0 3B F0 12 |
| K          | 4B        | 12 42 F0 42 F0 12 |
| L          | 4C        | 12 4B F0 4B F0 12 |
| M          | 4D        | 12 3A F0 3A F0 12 |
| N          | 4E        | 12 31 F0 31 F0 12 |
| O          | 4F        | 12 44 F0 44 F0 12 |
| P          | 50        | 12 4D F0 4D F0 12 |
| Q          | 51        | 12 15 F0 15 F0 12 |
| R          | 52        | 12 2D F0 2D F0 12 |
| S          | 53        | 12 1B F0 1B F0 12 |
| T          | 54        | 12 2C F0 2C F0 12 |
| U          | 55        | 12 3C F0 3C F0 12 |
| V          | 56        | 12 2A F0 2A F0 12 |
| W          | 57        | 12 1D F0 1D F0 12 |
| X          | 58        | 12 22 F0 22 F0 12 |
| Y          | 59        | 12 35 F0 35 F0 12 |
| Z          | 5A        | 12 1A F0 1A F0 12 |
| [          | 5B        | 54 F0 54          |
| \          | 5C        | 5D F0 5D          |
| ]          | 5D        | 5B F0 5B          |
| ^          | 5E        | 12 36 F0 36 F0 12 |
| _          | 5F        | 12 4E F0 4E F0 12 |

## ASCII Scan Codes (cont.)

| ASCII CHAR | ASCII HEX | KEY SCAN CODES    |
|------------|-----------|-------------------|
| `          | 60        | 0E F0 0E          |
| a          | 61        | 1C F0 1C          |
| b          | 62        | 32 F0 32          |
| c          | 63        | 21 F0 21          |
| d          | 64        | 23 F0 23          |
| e          | 65        | 24 F0 24          |
| f          | 66        | 2B F0 2B          |
| g          | 67        | 34 F0 34          |
| h          | 68        | 33 F0 33          |
| i          | 69        | 43 F0 43          |
| j          | 6A        | 3B F0 3B          |
| k          | 6B        | 42 F0 42          |
| l          | 6C        | 4B F0 4B          |
| m          | 6D        | 3A F0 3A          |
| n          | 6E        | 31 F0 31          |
| o          | 6F        | 44 F0 44          |
| p          | 70        | 4D F0 4D          |
| q          | 71        | 15 F0 15          |
| r          | 72        | 2D F0 2D          |
| s          | 73        | 1B F0 1B          |
| t          | 74        | 2C F0 2C          |
| u          | 75        | 3C F0 3C          |
| v          | 76        | 2A F0 2A          |
| w          | 77        | 1D F0 1D          |
| x          | 78        | 22 F0 22          |
| y          | 79        | 35 F0 35          |
| z          | 7A        | 1A F0 1A          |
| {          | 7B        | 12 54 F0 54 F0 12 |
|            | 7C        | 12 5D F0 5D F0 12 |
| }          | 7D        | 12 5B F0 5B F0 12 |
| ~          | 7E        | 12 0E F0 0E F0 12 |
| Del        | 7F        | 71 F0 71          |

### **Warranty**

*L3 Systems guarantees this product to be free of defects in material and workmanship for 180 days from date of shipment to the end user. L3 Systems will repair or replace (at our option) products within the warranty period at no charge for parts and labor. All returns must obtain a Return of Merchandise Authorization number (RMA) available on request from L3 Systems. Shipping costs (plus customs and duty, if any) to and from L3 Systems must be paid by the user. Damage or defect caused by accident, misuse or neglect is not covered. Damage or defect caused by shipping is excluded. L3 Systems shall not be liable for any consequential damage or losses from the use of, or inability to use its products. Any unauthorized repair or modification of the product voids the warranty. L3 Systems makes no other warranty, express or implied, nor have we authorized anyone to make representations to the contrary.*

# Keyat Keyboard Port Adapter

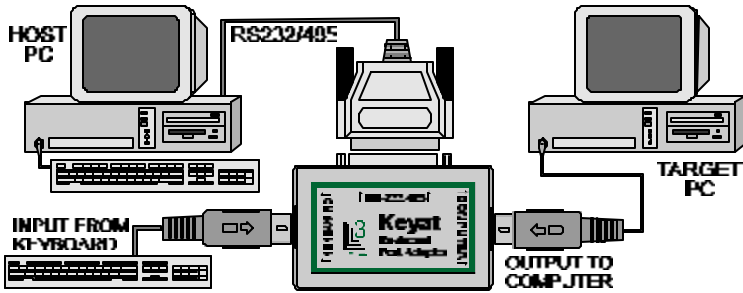

The Keyat Keyboard Port Adapter allows you to make an RS-232 or RS-485 connection to a computer's keyboard port, and still use the keyboard. Typical uses are:

- ◆ **Testing Software** - Test software by sending it simulated keystrokes from another computer.
- ◆ **Multi-system Testing** - Use host system to simulate keystrokes for up to 58 computers.
- ◆ **Remote Access** - Use the Keyat to remotely access systems where software does not provide other options.
- ◆ **Monitor Keyboard Sessions** - You can monitor keyboard session to develop keyboard test scripts.
- ◆ **Connect a Keyboard to an RS-232 Port** - You can use a Keyat to connect a keyboard to a computer's RS-232 port, and receive key codes from the keyboard.
- ◆ **Attaching input devices** - Allows you to attach RS-232/RS-485 devices to the keyboard port such as bar code readers, scales, and credit card readers.

Some advanced features of the Keyat Adapter are:

- ◆ **Accepts a Variety of Keyboard Data** - Accepts printable ASCII and encoded ASCII Hex, DOS scan codes, and direct keyboard key codes.
- ◆ **LED Use Indicator** - Status of remote connect.
- ◆ **Computer Keyboard Port Cable Provided** - Just plug it in and go.