

Not Recommended for New Installations.

Please contact Technical Support for more information.

RS-422/RS-485 Line Tester

Model 485T

Documentation Number 485T1995

This product

Designed and Manufactured

In Ottawa, Illinois

USA

of domestic and imported parts by

B&B Electronics Mfg. Co. Inc.

707 Dayton Road -- P.O. Box 1040 -- Ottawa, IL 61350

PH (815) 433-5100 -- FAX (815) 433-5105

Internet:

<http://www.bb-elec.com>

orders@bb-elec.com

support@bb.elec.com

© 1992 B&B Electronics -- Revised August 1992

TABLE OF CONTENTS

INTRODUCTION	1
RS-422 AND RS-485 STANDARDS	1
CONTROLS AND CONNECTIONS ON THE 485T	6
A AND B TERMINALS	6
GROUND TERMINAL	6
THRESHOLD POT	7
POSITIVE THRESHOLD EXCEEDED LED	7
NEGATIVE THRESHOLD EXCEEDED LED	7
RS-422/RS-485 SWITCH	8
TERMINATION SWITCH	8
POWER	8
RS-232 DATA OUT CONNECTOR	8
RS-422/485 TEST	9

INTRODUCTION

The Model 485T Tester can be used to check the condition of signals at any node on an RS-422 or RS-485 network. The tester determines if the maximum permissible negative or positive voltages are being exceeded. If these voltage levels are exceeded it is possible to damage the RS-422/485 receivers and drivers. The tester also checks to see if minimum required differential voltages exist on the lines. The tester uses the normal data that is transmitted on the line to check the value of the minimum differential voltage. There is an RS-232 output that can be used to view the network data.

RS-422 AND RS-485 STANDARDS

The RS-232 Standard (Interface Between Data Terminal Equipment and Data Circuit-Terminating Equipment Employing Serial Binary Data Interchange) was developed many years ago by the Electronic Industries Association (EIA). It was used to connect modems to terminals for dial-up computer systems. Since the modem and terminal were usually located close to each other, wire length was not much of a factor in the standard. RS-232 maximum wire lengths were set at 50 feet. RS-232 lines can run farther with special (low capacitance) wire but there is a practical limit of 300 or so feet.

The EIA then developed two newer standards to allow serial data communications to go past the 50 foot barrier. The first is RS-422, Electrical Characteristics of Balanced Voltage Digital Interface Circuits. The second is RS-485, Standard for Electrical Characteristics of Generators and Receivers for use in Balanced Digital Multipoint Systems. Using these standards, wire lengths of about 4000 feet are attainable. This is possible by using two wires for each signal instead of the one wire used in RS-232.

A typical RS-232 system can have eight wires, seven signals and one ground, not all of which are used in every system. As each signal goes high or low (typically +12 and -12 volts) it uses the one ground wire as a reference. Ground currents can cause confusion. Also, the RS-232 drivers are not capable of driving much more than 2500 picofarads before the signal on the line is badly distorted.

Both RS-422 and RS-485 use two wires for each signal. These two wires are driven differentially. When one wire is low the other is

high and vice-versa. Also, the drivers are capable of driving a wire with as much as 25 times more capacitance before the signal is badly distorted. Most system designers try to minimize the number of signals used because these standards take two wires per signal. This is one reason most RS-422 and RS-485 systems are either two-wire with ground or four-wire with ground.

There are two major differences between RS-422 and RS-485. The first is that with RS-422, one driver can only drive 10 receivers. With RS-485, one driver can drive 32 receivers. Secondly, RS-485 drivers can be "tri-stated" or turned off. This allows you to put all 32 drivers and receivers on one two-wire line. When a device needs to output data, it first turns on its driver to seize the line and then sends its data. The other 31 devices will be listening. RS-422 requires at least two pairs of wires, one pair to send data in one direction and the other for return data.

Typically, the RS-422 or RS-485 driver will switch between +5 volts and ground. Since devices can be long distances apart, they can be powered on different power lines or transformers that can force their "reference grounds" to be at different voltages. The RS-422 Standard allows the signal lines to go as high as +7 volts and as low as -7 volts. The RS-485 Standard allows +12 volts and -7 volts.

Another requirement is that the differential input voltage at the receiver must be more than 0.2 volts. The differential voltage starts out from the driver at about 2 volts but the resistance, inductance, and capacitance of the wire combine to attenuate this signal. As the wire gets longer, this voltage will get smaller until it falls below the 0.2 volt level and then communications can no longer be guaranteed.

Both specifications discuss termination of the two-wire line. A typical two-wire twisted-pair line looks like a 100 ohm transmission line. In general, the line does not need to be terminated for slow data rates or for short-wire lengths.

More information and the RS-232, RS-422, and RS-485 Standards are available from:

ELECTRONICS INDUSTRIES ASSOCIATION

Engineering Department
2001 Eye Street N. W.
Washington, DC 20006

Phone: (202) 457-4900 --- FAX: (202) 457-4985

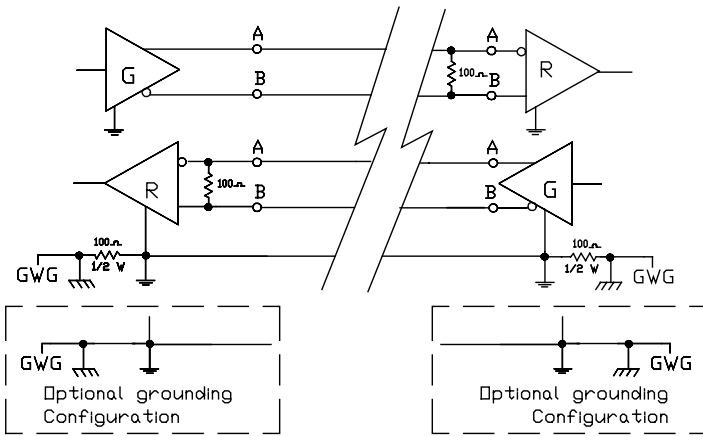

- G ■ Generator
- R ■ Receiver
- ⏏ ■ Circuit ground or circuit common
- ⏏ ■ Protective ground or frame ground
- GWG ■ Green wire ground or power system ground

Typical RS-422 Four Wire Network

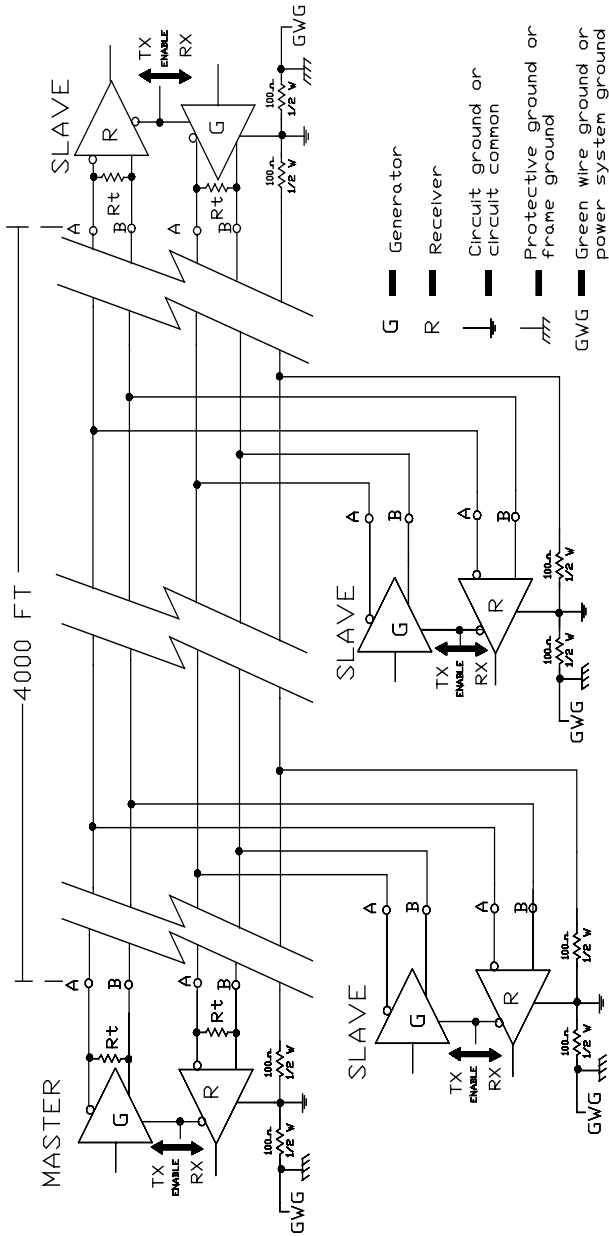

TYPICAL RS-485 FOUR WIRE MULTIDROP NETWORK

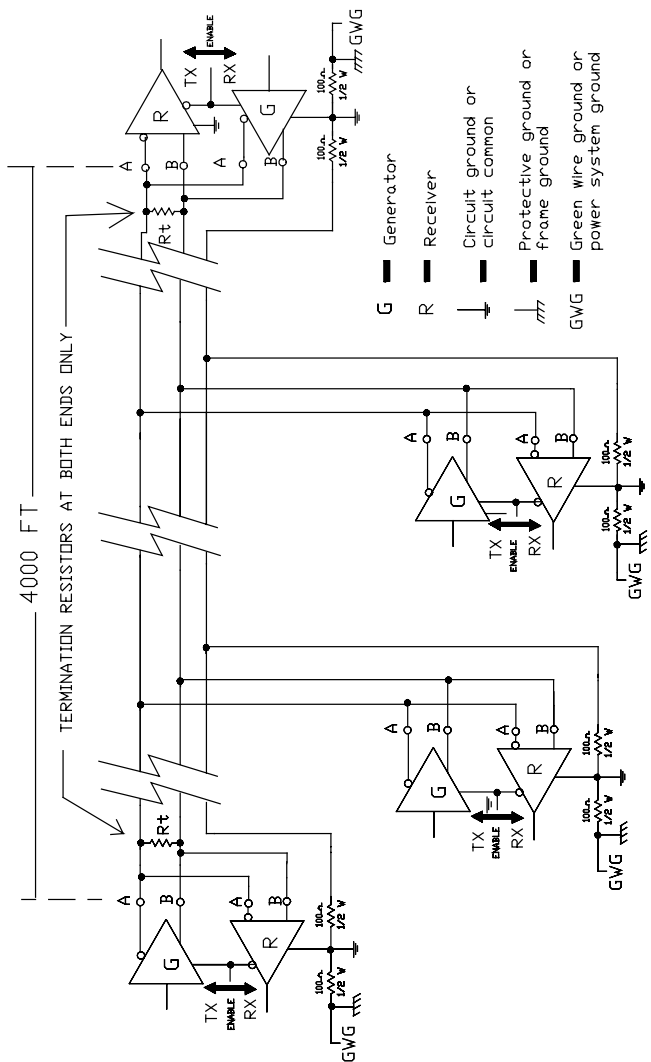

TYPICAL RS-485 TWO WIRE MULTIDROP NETWORK

CONTROLS AND CONNECTIONS ON THE 485T

A and B Terminals

The two signal lines used in an RS-422 or RS-485 network should be labeled A and B. These lines should be connected to the A and B terminals of the 485T Tester. If your lines are not marked (or are marked using another method) you can use a DC voltmeter to determine which is which. With no data being sent, the A line will be negative with respect to the B line. On an RS-485 network, if all of the drivers are off, the voltmeter will read zero volts. Under these conditions, it is not possible to use a voltmeter to determine which line is A and which is B. Having them connected backwards will only be a problem when using the RS-232 Data Out Connector.

Some networks will use four wires instead of two. In these networks, one pair will be used to send data out from a master device. The other pair will send data back from one or a multitude of other devices. These networks can be tested using the 485T by treating them as two separate networks. You would first run your tests on one pair of signal lines and then run them again on the other pair.

NOTE: Make sure that you are connected to the correct two lines when using the tester. It is possible for the tester to look like it is working properly when one line is connected and the other is floating or connected to a wire in another pair.

Ground Terminal

The GND terminal on the 485T Tester should be connected to Signal Ground for the device under test. The Signal Ground is usually the same as the power supply ground for your unit. Some systems will also have a Frame Ground that is usually connected to the "Green Wire Ground" of your power supply AC plug. Frame Ground can also be connected to the wire shield if your pair of wires is shielded. You want Signal Ground not Frame Ground. In some systems, Frame Ground will be connected to Signal Ground, usually through a 100 ohm one-half watt resistor. You still want to be connected to Signal Ground to make proper measurements, since they may be at different voltages. There is a 100 ohm one-half watt resistor connected internally between the GND terminal and the internal Signal Ground (power supply ground) of the 485T. This is the optional grounding method from both the RS-422 and the RS-485 Standard.

Threshold Pot

The large pot in the center of the 485T is the threshold pot. In order for RS-422/485 to work properly, you should have a differential input voltage of more than .2 volts across the two lines at the RS-422/485 receiver. By adjusting this pot you can determine the amplitude of the RS-422/485 signals. Start with the knob turned down to zero volts (full clockwise) with data being sent on your network. The Data LED should be blinking with the data providing that the network is not running at too high of a baud rate. At higher baud rates the LED may be on. Turn the threshold pot up (counterclockwise) until the Data LED stops blinking or turns off. The reading of the pot at that point is the differential input voltage. This reading should be .2 volt or more. If the LED does not stop blinking or turn off with the pot all the way up (full counterclockwise) the reading is above 1 volt. Readings above 1 volt are not available since it would make the lower voltage readings difficult to read. Readings above 1 volt indicate that differential voltage is more than adequate.

Positive Threshold Exceeded LED

The RS-422 Standard states that a network should not have a positive common mode voltage of more than 7 volts. This means that the difference between Signal Ground and either the A or B input should not be more than positive 7 volts. For RS-485 the maximum is 12 volts. The Positive Threshold Exceeded LED will light if these limits are exceeded. This reading is taken with respect to Signal Ground so the GND terminal must be connected properly for the reading to be correct.

NOTE: The RS-422/RS-485 switch is used to control this threshold. It must be in the proper position for these readings to be correct.

Negative Threshold Exceeded LED

Both the RS-422 and the RS-485 Standards state that the network should not have a negative common mode voltage of more than 7 volts. This means that the difference between Signal Ground and either the A or B input should not be more than minus 7 volts. The Negative Threshold Exceeded LED will light if this limit is exceeded. Again this reading is taken with respect to Signal Ground so the GND terminal must be connected properly for the reading to be correct.

RS-422/RS-485 Switch

This switch controls the positive threshold voltage for the Positive Threshold LED only. When the switch is in the RS-422 position, the positive threshold is +7 volts. When it is in the RS-485 position, the positive threshold is +12 volts. This switch has no effect on the Data LED, the Threshold Pot, or on the Negative Threshold LED.

Termination Switch

In some cases RS-422 and RS-485 pairs are terminated. This termination is usually needed only for long or high speed networks. Terminations usually consist of a 100 ohm one-half watt resistor located at each end of the network. In some complicated multi-drop networks it may be hard to determine exactly where the "ends" are. A 100 ohm one-half watt termination resistor is included in the 485T. It may be helpful if you are testing an existing network with no terminations and want to see what happens if you terminate it at one point. Normally, you should leave this switch OFF (down).

Power

The 485T will work from a nine-volt battery or from 12 VDC through the 2.5 mm jack marked DC Power 12VDC IN. When you plug in the external power supply (available from B&B Electronics as the Model 485PS) the battery is automatically disconnected.

RS-232 Data Out Connector

This is a standard DB-25S RS-232 connector. When the DATA LED is blinking, any RS-422/485 data on the A & B inputs is converted to the RS-232 format and output on pin 2. You can connect this to a device that has an RS-232 port and can read your data. Be sure you turn the threshold pot all the way down (clockwise) to zero. For use on standard ASCII data B&B Electronics sells a program called BreakOut II that will turn a PC into a serial data monitor. With it and a PC you can monitor data on your RS-422/485 network.

NOTE: If your data is garbled you may have the A and B lines connected backwards or the threshold pot may not be all the way down to zero. It is also possible that the RS-422/485 signal may be too weak.

RS-422/485 TEST

A typical test on an RS-422/485 network might go like this: First start by locating the two wires used for the RS-422/485 network and try to determine which is A and which is B. Also, locate the Signal Ground. This may be the same as the ground on the DC power supply that powers the RS-422/485 device.

Connect the Signal Ground to the GND terminal. Connect the A and B terminals to what you think are the A and B wires. Turn the Threshold Pot to zero (full clockwise), the TERMINATION off, the RS-422 and RS-485 switch to the proper position, and the POWER switch ON. If you are not sure which is A and which is B, test them with a DC voltmeter. With no data being sent, the A line should be negative with respect to the B line. Getting the A and B lines correct is only important for the RS-232 DATA OUT CONNECTOR. It will have no affect on the other tests.

The POSITIVE and NEGATIVE THRESHOLD EXCEEDED LEDs should both be off, both when data is being sent and when the network is idle. If either of these LEDs is on or blinking, you may have a grounding problem. You should first check that the RS-422/RS-485 switch is in the proper position and that the Signal Ground is connected correctly to the 485T. Refer to B&B Electronics' free RS-422/485 Application Note for information on proper grounding of your network.

NOTE: If the positive or negative thresholds are exceeded, you may damage your RS-422 or RS-485 line receivers. If either of the LEDs is on or blinking you should find out why and fix the problem as soon as possible.

For example, if you have a network with two nodes located in two different buildings about 4000 feet apart. An RS-422 driver in building A can be switching between +5 volts and ground and be powered from building A's power lines. An RS-422 receiver can be located in building B with a ground potential that is 3 volts DC lower than building A. That receiver will see +8 volts for a high (5+3 volts) and +3 volts for a low (0+3 volts). This is allowed under both standards and should work fine. However, if the difference in ground potential is 10 VDC lower, the high (5+10 volts) will be +15 volts and is NOT allowed. The ground difference voltage can also be an AC voltage which could confuse things even more.

See B&B Electronics' free RS-422/485 Application Note for information on proper wiring and grounding of an RS-422/485 network.

If the POSITIVE and NEGATIVE THRESHOLD LEDs are both off, you can then test for proper signal amplitude. With the THRESHOLD pot turned to zero (full clockwise), the DATA LED should blink or stay on when data is sent. When data is being sent on the network, turn the THRESHOLD pot counterclockwise until the LED goes out.

If, for instance, the LED goes out when the pot is pointing at .5, then you have a differential input voltage of plus or minus .5 volts. Both RS-422 and RS-485 require at least plus or minus .2 volts to work properly. If your network node is below this level, you may need a line booster, a repeater, or you may need to change your wiring layout. Refer to B&B Electronics' free RS-422/485 Application Note for information on network wiring. If the LED does not go out with the THRESHOLD pot turned up to 1.0 (full counterclockwise), then your differential input voltage is more than 1 volt. Most RS-422/485 drivers start out with a differential of about 2 volts but the resistance, inductance, and capacitance in the line can reduce it considerably.

NOTE: The differential voltage you are trying to measure is the RECEIVED voltage. You should only make the threshold measurement when the node you are testing is RECEIVING data, not when it is transmitting. If you have a multiple node system with each node at a different location, you may have to have each node transmit separately while you take a reading. You may get a different differential voltage reading from each node.

For example, if you have an RS-485 network with five nodes each located 1000 feet apart for a total of 4000 feet. Node 1 is at one end, node 2 next, etc., and node 5 is at the far end. If you connect the 485T Tester to node 1 and watch while data is sent from node 2, there will only be 1000 feet of wire and the signal should be fairly strong.

However, when node 5 sends data, there will be 4000 feet of wire and the signal will be weaker. If you have the different nodes sending randomly it will be impossible to take a reading. You have to have only one node sending to take a proper reading. You may be able to turn the power off unwanted nodes to stop them from transmitting. However, this may change the loading on the line, so be careful using this method.

You can then use the 485T Tester to monitor the data that is being sent or received on your network. If you have a datascop or a computer running a datascop-like program you can connect it to the RS-232 DATA OUT connector on the 485T. A typical program would be BreakOut II which is available from B & B Electronics. The RS-232 DATA OUT connector is wired as a DTE with data output on pin 2. Pin 4 is connected to pin 5 and pin 6 is connected to pins 8 and 20 for handshake loopback. Pin 7 is ground and there is no connection to pin 3.

NOTE: If the data you receive is garbled, you may have the A & B connectors backwards. Try reversing them.

With the 485T connected and the THRESHOLD pot turned to zero (full clockwise), any RS-422/485 data on the network will appear as RS-232 data at pin 2 of the RS-232 DATA OUT jack. If you have a four-wire network you can only view one pair of lines at a time. This means that you can only see data transmitted from that node or data received by that node, not both at the same time. On a two-wire node (RS-485) you can see both received and transmitted data at the same time.

NOTE: Your datascop must be able to receive data at the same baud rate, etc. as the data that is transmitted on the RS-422/485 network.

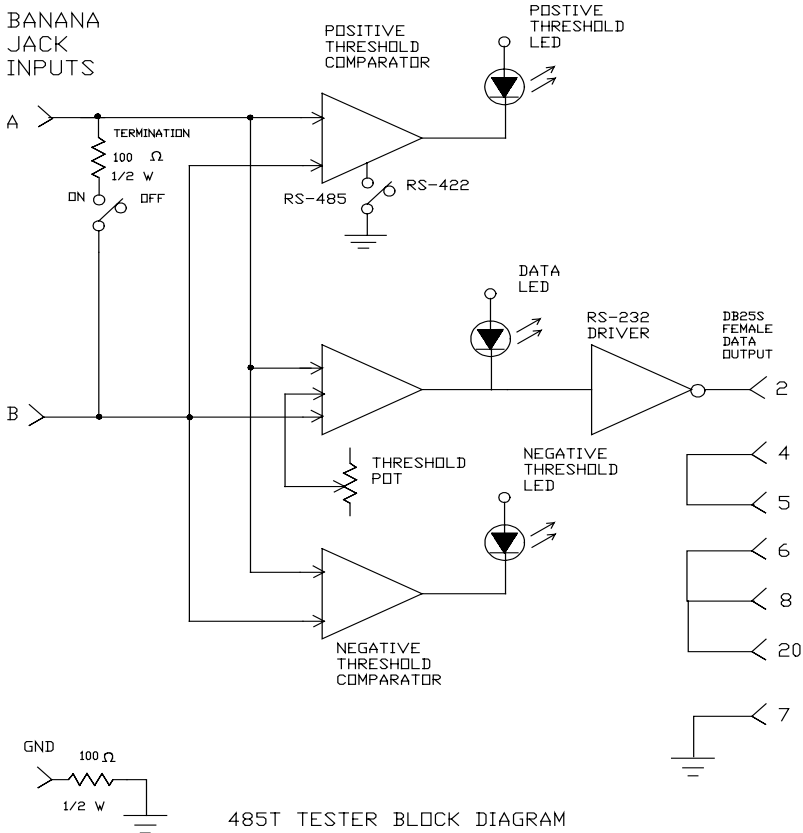

485T TESTER BLOCK DIAGRAM