

*Asynchronous, Carrier Controlled
Fiber Optic Modem CE
Models: 1110F 1110M
Document No. 1110F1799*

B & B Electronics

International Headquarters

B&B Electronics Mfg. Co. Inc.
707 Dayton Road -- P.O. Box 1040 -- Ottawa, IL 61350 USA
Phone (815) 433-5100 -- General Fax (815) 433-5105
Home Page: www.bb-elec.com
Sales e-mail: sales@bb-elec.com -- Fax (815) 433-5109
Technical Support e-mail: support@bb.elec.com -- Fax (815) 433-5104

European Headquarters

B&B Electronics Ltd.
Westlink Commercial Park, Oranmore, Co. Galway, Ireland
Phone (353) 91 792444 -- Fax (353) 91 792445
Home Page: www.bb-europe.com
Sales e-mail: sales@bb-europe.com
Technical Support e-mail: support@bb-europe.com

1996 B&B Electronics -- Revised April 1999

TABLE OF CONTENTS

1.0 WARRANTY INFORMATION	1
1.1 RADIO AND TV INTERFERENCE.....	1
1.2 SERVICE	2
2.0 GENERAL INFORMATION	3
2.1 FEATURES.....	3
2.2 DESCRIPTION	3
3.0 CONFIGURATION	5
3.1 SETTING THE EXTERNAL DCE/DTE SWITCH	5
3.2 SETTING INTERNAL DIP SWITCHES	5
3.2.1 Detailed Switch Settings.....	6
SWITCH 1: CARRIER CONTROL	6
SWITCHES 2 & 3: RTS/CTS DELAY	6
SWITCH 4: ENABLE CARRIER DETECT LED.....	7
SWITCH 5: ENABLE FIBER OPTIC OUTPUT LED	7
4.0 INSTALLATION	8
4.1 FIBER CONNECTIONS.....	8
4.2 RS-232 CONNECTION.....	8
5.0 OPERATION	9
5.1 LED STATUS MONITORS.....	9
5.2 POWER UP	9
APPENDIX A. SPECIFICATIONS	A-1
APPENDIX B. PIN CONFIGURATIONS	B-1
APPENDIX C. BLOCK DIAGRAM	C-1
APPENDIX D: DECLARATION OF CONFORMITY	D-1

1.0 WARRANTY INFORMATION

B&B Electronics warrants all Model 1110 components be free from defects, and will—at our option—repair or replace the product should it fail within one year from the first date of shipment.

This warranty is limited to defects in workmanship or materials, and does not cover customer damage, abuse or unauthorized modification. If this product fails or does not perform as warranted, your sole recourse shall be repair or replacement as described above. Under no condition shall B&B Electronics be liable for any damages incurred by the use of this product. These damages include, but are not limited to, the following: lost profits, lost savings and incidental or consequential damages arising from the use of or inability to use this product. B&B Electronics specifically disclaims all other warranties, expressed or implied, and the installation or use of this product shall be deemed an acceptance of these terms by the user.

1.1 RADIO AND TV INTERFERENCE

The Model 1110 generates and uses radio frequency energy, and if not installed and used properly—that is, in strict accordance with the manufacturer's instructions—may cause interference to radio and television reception. The Model 1110 has been tested and found to comply with the limits for a Class A computing device in accordance with the specifications in Subpart J of Part 15 of FCC rules, which are designed to provide reasonable protection from such interference in a commercial installation. However, there is no guarantee that interference will not occur in a particular installation. If the Model 1110 does cause interference to radio or television reception, which can be determined by turning the power off or disconnecting the RS-232 interface, the user is encouraged to try to correct the interference by one of the following measures: moving the computing equipment away from the receiver, re-orienting the receiving antenna and/or plugging the receiving equipment into a different AC outlet (such that the computing equipment and receiver are on different branches).

1.2 SERVICE

All warranty and non-warranty repairs must be returned freight prepaid and insured to B&B Electronics. All returns must have a Return Materials Authorization number on the outside of the shipping container. This number may be obtained from B&B Electronics Customer Service Department at (815) 433-5100 x218. Packages received without an RMA number will not be accepted

B&B Electronics' technical staff is also available to answer any questions that might arise concerning the installation or use of your Model 1110. Technical Service hours: **8AM to 5PM CST, Monday through Friday.**

2.0 GENERAL INFORMATION

Thank you for your purchase of this B&B Electronics product. This product has been thoroughly inspected and tested and is warranted for One Year parts and labor. If any questions or problems arise during installation or use of this product, please do not hesitate to contact B&B Electronics Technical Support at (815) 433-5100.

2.1 FEATURES

- Communicates over dual optical fibers
- Data rates to 19.2 Kbps
- Distances to 3.2 Km (2 miles)
- Plugs directly into an RS-232 port
- Immune to RFI/EMI noise, ground loops and transient surges
- Easily accessible DCE/DTE switch
- DIP switch-selectable carrier control
- Requires no AC power or batteries
- Two easy-to-read status indicators
- Fits into tight installation spaces
- Male or female DB-25 and SMA or ST connectors available

2.2 DESCRIPTION

The Model 1110 miniature RS-232 fiber optic modem brings fiber to the desktop. Communicating over dual optical fibers, the Model 1110 supports data rates to 19.2 Kbps and distances to 3.2 Km (2 miles). The Model 1110 operates full or half duplex and plugs directly into a workstation's RS-232 port.

Like all fiber optic modems, the Model 1110 is inherently immune to RFI/EMI noise, ground loops and transient surges. The carrier may be switch selected as either "Continuously On" or "Controlled by RTS", while an easily accessible DCE/DTE switch eliminates the need for cumbersome RS-232 crossover cables. Two easy-to-read LED indicators monitor the status of carrier detect and fiber optic output. Drawing all necessary power from the RS-232 interface, the Model 1110 requires no AC power or batteries to operate.

Measuring only 6.8 x 5.3 x 1.9 cm (2.66" x 2.10" x .73"), the Model 1110 is able to fit into tight installation spaces. A convenient pop-open/snap-shut ABS plastic case allows easy access to configuration switches. On the RS-232 side, the Model 1110 comes equipped with either a male or female DB-25 connector; on the fiber side, it is available with a choice of SMA or ST connectors.

3.0 CONFIGURATION

The Model 1110 is simple to install and is ruggedly designed for excellent reliability: just set it and forget it. This section will describe how to configure the Model 1110's DCE/DTE switch and how to set the internal DIP switches.

3.1 SETTING THE EXTERNAL DCE/DTE SWITCH

For your convenience, the Model 1110 has an externally accessible DCE/DTE switch (see Figure 1, below). If the device connected to the Model 1110 is a PC, terminal or host computer (or is wired like one), set the switch to "DCE". This causes the Model 1110 to behave like Data Communications Equipment and transmit data on pin 3. If the device connected to the Model 1110 is a modem or multiplexer (or is wired like one), set the switch to "DTE". This setting causes the Model 1110 to behave like Data Terminal Equipment and transmit data on pin 2.

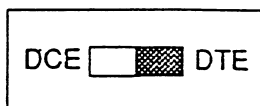

Figure 1. Externally accessible DCE/DTE switch

3.2 SETTING INTERNAL DIP SWITCHES

The Model 1110's eight internal DIP switches allow configuration of flow control and LED options. To set the internal switches, follow these steps:

- 1) Open the Model 1110 case by inserting a small flat-blade screwdriver between the case lip and DB-25 connector and twisting gently (see Figure 2).
- 2) Having exposed the Model 1110 PC board, you will see the miniature DIP switch packet on the underside of the board, on the side opposite the DCE/DTE switch.
- 3) To set the switches, use a small screwdriver and gently push each switch to its proper setting. The ON position is printed on the switch packet.
- 4) Fit the case halves together and push to snap closed.

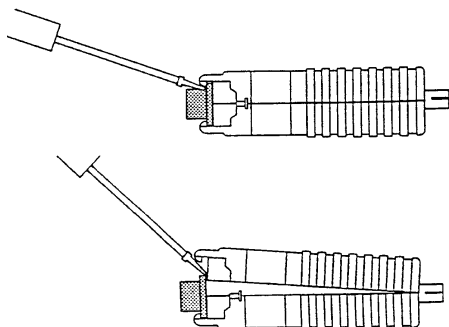

Figure 2. Use a small screwdriver to open the Model 1110 case.

3.2.1 Detailed Switch Settings

The DIP switches on the Model 1110 PC board are labeled 1-8. Only switches 1-5 are used. Switches 6-8 are reserved for future use. Below are descriptions of the Model 1110 DIP switch settings.

Switch 1: Carrier Control

The setting for Switch 1 determines whether carrier is constantly on or controlled by RTS.

Carrier	SW1
Constant	OFF*
Controlled by RTS	ON

*Factory default

Switches 2 & 3: RTS/CTS Delay

The settings for Switches 2 & 3 determine whether the RTS/CTS delay will be 0 mS, 79.5 mS or 9.5 mS.

RTS/CTS Delay	SW2	SW3
0 mS	OFF	OFF
79.5 mS	ON	OFF
9.5 mS	ON*	ON*

*Factory default

Switch 4: Enable Carrier Detect LED

The setting for Switch 4 determines whether the Model 1110 "carrier detect" LED indicator is enabled. When enabled, the carrier detect LED will glow red if a proper carrier frequency is recognized.

Carrier Detect LED	SW4
Enabled	ON*
Disabled	OFF

*Factory default

Switch 5: Enable Fiber Optic Output LED

The setting for Switch 5 determines whether the Model 1110 "fiber optic output" LED indicator is enabled. When enabled, the fiber optic output LED will glow red to indicate presence of infrared output and transmit carrier.

F.O. Output LED	SW5
Enabled	ON*
Disabled	OFF

*Factory default

Switches 6 through 8: For Future Use

4.0 INSTALLATION

The Model 1110 is easy to install. After configuring the DIP switches, simply connect the two fiber cables and then connect the RS-232 interface. Figure 3 below shows the location of the fiber connections on the Model 1110's rear panel.

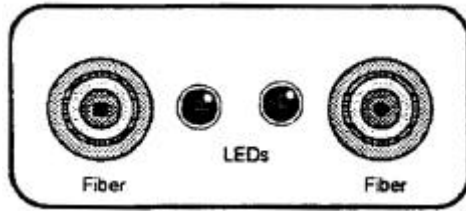

Figure 3. Rear panel of Model 1110 showing fiber connections.

4.1 FIBER CONNECTIONS

The Model 1110 short range modems are designed to work in *pairs*. You will need one at each end of a dual fiber cable. This cable connects to each Model 1110 using either an ST or an SMA connector. Figure 4 below shows a close up of each of these connector types.

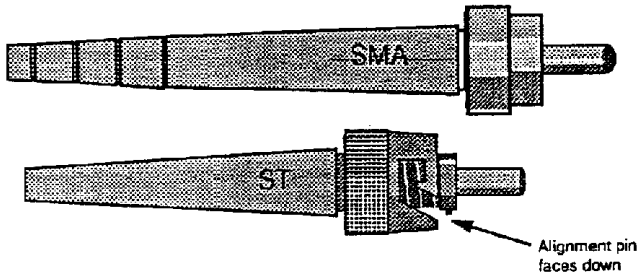

Figure 4. Close-up of ST and SMA connections.

4.2 RS-232 CONNECTION

Because the Model 1110 is designed to behave as either a DCE or a DTE device, it does not need special cables to operate. Always use a *straight through* RS-232 cable.

5.0 OPERATION

Once you have configured each Model 1110 properly and connected the fiber and RS-232 cables, you are ready to operate the units. This section describes the LED status monitors and the power up process.

5.1 LED STATUS MONITORS

The Model 1110 features two status LEDs that indicate the condition of carrier detect and fiber optic output. Figure 5 below shows the back panel location of each LED. Following Figure 5 is a description of each LED's function.

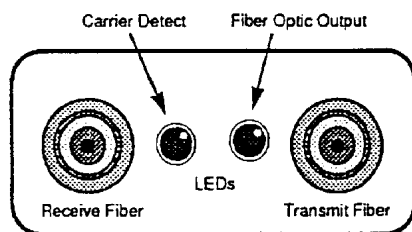

Figure 5. Back panel view of Model 1110.

- The "Carrier Detect" LED will glow red when a proper carrier frequency is recognized.
- The "Fiber Optic Output" LED will glow red to indicate presence of infrared output and transmit carrier.

5.2 POWER UP

Once the Model 1110 is properly installed, it should operate transparently—as if it were a standard cable connection. Since operating power is derived from the RS-232 data and control signals, there is no "ON/OFF" switch. All data signals from the RS-232 interface are passed straight through.

When the local and remote Model 1110's are both powered up and passing data normally, the following LED conditions will exist:

- Carrier detect = solid red
- Fiber optic output = solid red

APPENDIX A. SPECIFICATIONS

Transmission Line: Dual optical cable

Transmission Mode: Asynchronous, half or full duplex, point-to-point

Interfaces: EIA RS-232, CCITT V.24

Data Rates: 0 -19.2 Kbps

Distance: 3.2 Km (2 miles) over continuous fiber

RTS/CTS Delay: Switch-selectable: No delay, 9.5 mS, 79.5 mS

Receiver Sensitivity: -45 dBm

Coupled Power Output: -30 to -36 dBm

Optic Wavelength: 850 nm

LED Indicators: Carrier Detect and Fiber Optic Output

Connectors: DB-25 male or female on RS-232 side; ST or SMA connectors on fiber side

Power Supply: No external power required; uses power from RS-232 data and control signals

Temperature Range: 0-60°C (32-140°F)

Altitude: 0-4572 meters (0-15,000 feet)

Humidity: Up to 95% non-condensing

Weight: 62 grams (2 oz.)

Dimensions: 6.8 x 5.3 x 1.9 cm (2.66" x 2.10" x 0.73")

APPENDIX B. PIN CONFIGURATIONS

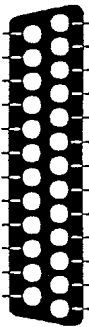
DIRECTION	"DCE" STANDARD SETTING	DIRECTION
To Model 1110	 <p>1- (FG) Frame Ground 2- (TD) Transmit Data 3- (RD) Receive Data 4- (RTS) Request to Send 5- (CTS) Clear to Send 6- (DSR) Data Set Ready 7- (SG) Signal Ground 8- (DCD) Data Carrier Detect</p>	To Model 1110 From Model 1110 To Model 1110 From Model 1110 From Model 1110 From Model 1110

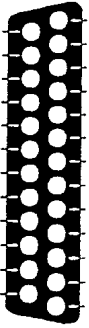
DIRECTION	"DTE" STANDARD SETTING	DIRECTION
From Model 1110	 <p>1- (FG) Frame Ground 2- (TD) Transmit Data 3- (RD) Receive Data 4- (RTS) Request to Send 5- (CTS) Clear to Send 6- (DSR) Data Set Ready 7- (SG) Signal Ground 8- (DCD) Data Carrier Detect</p>	From Model 1110 To Model 1110 From Model 1110 To Model 1110 To Model 1110 To Model 1110

APPENDIX C. BLOCK DIAGRAM

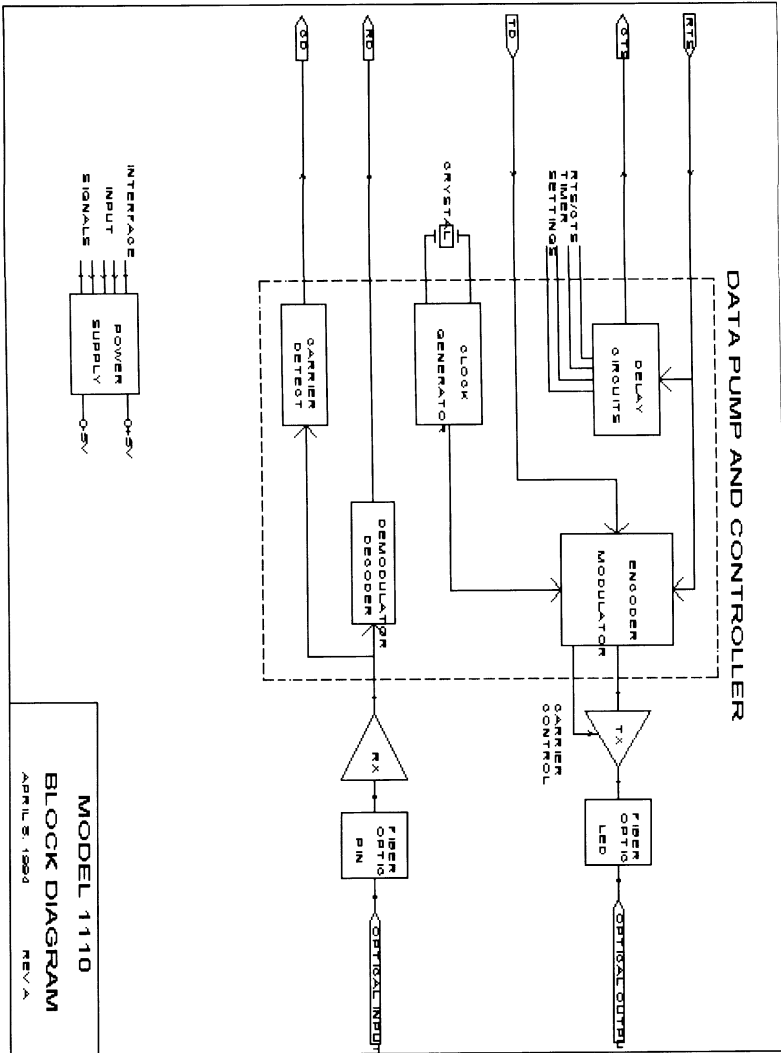

APPENDIX D: Declaration of Conformity

DECLARATION OF CONFORMITY	
WITH	
EUROPEAN UNION DIRECTIVE	
Date of Issue:	09 December 1998
Certificate Reference:	00149DDO
Directive:	89/367EEC Electromagnetic Compatibility
Conforming Apparatus:	Data Communication Devices B & B Models per attached sheet
Manufacturer:	Parco Electronics Company 7622 Ravenhill Road Drive, Gaithersburg, Maryland 20879 U. S. A.
Harmonized Standards Applied:	EN55022 Class A Radiated and Conducted Emissions EN50082-1 Generic Immunity Part I Residential, Commercial and Light Industrial Environment

We hereby certify that the apparatus described above conforms with the protection requirements of Council Directive 89/367EEC as the approximation of the laws of the Member States relating to electromagnetic compatibility.

Gaithersburg, Maryland

C. J. Whitley
C. J. Whitley, Compliance Engineer

Robert E. Purton
Robert E. Purton, President

DECLARATION OF CONFORMITY	
WITH	
EUROPEAN UNION DIRECTIVE	
Date of Issue:	09 December 1998
Conforming Apparatus:	Data Communication Devices B & B Models as listed below:
Models:	1110a-ST, 1140a-ST

FEDERAL COMMUNICATIONS COMMISSION RADIO FREQUENCY INTERFACE STATEMENT

Class A Equipment

This equipment has been tested and found to comply with the limits for Class A digital device, pursuant to Part 15 of the FCC Rules. These limits are designed to provide reasonable protection against harmful interference when the equipment is operated in a commercial environment. This equipment generates, uses, and can radiate radio frequency energy and, if not installed and used in accordance with the instructions, may cause harmful interference to radio communications. Operation of this equipment in a residential area is likely to cause harmful interference, in which case the user will be required to correct the interference at personal expense.