



SSP-200/300
Single Channel RS-422/485 PCMCIA
Asynchronous Adapter

for PCMCIA Card Standard compatible machines

User's Manual

QUATECH, INC.
662 Wolf Ledges Parkway
Akron, Ohio 44311

TEL: (330) 434-3154
FAX: (330) 434-1409
www.quatech.com

Warranty Information

Quatech Inc. warrants the SSP-200/300 to be free of defects for one (5) year from the date of purchase. Quatech Inc. will repair or replace any adapter that fails to perform under normal operating conditions and in accordance with the procedures outlined in this document during the warranty period. Any damage that results from improper installation, operation, or general misuse voids all warranty rights.

The authors have taken due care in the preparation of this document and any associated software program(s). In no event will Quatech Inc. be liable for damages of any kind, incidental or consequential, in regard to or arising out of the performance or form of the materials presented herein and in the program(s) accompanying this document. No representation is made regarding the suitability of this product for any particular purpose.

Quatech Inc. reserves the right to edit or append to this document or the product(s) to which it refers at any time and without notice.

Please complete the following information and retain for your records. Have this information available when requesting warranty service.

Date of purchase: _____

Model Number: SSP-200/300

Product Description: Single Channel Asynchronous RS-422/485
Communications PCMCIA Adapter

Serial Number: _____

CE Declaration of Conformity

Manufacturer's Name: Quatech, Inc.

Manufacturer's Address: 662 Wolf Ledges Parkway
Akron, OH 44311 (USA)

Application of Council Directive: 89/336/EEC

**Standards to which
Conformity is Declared:** * EN50081-1
(EN55022)
* EN50082-1
(IEC 801-2, IEC 801-3, & IEC 801-4)

Type of Equipment: Information Technology Equipment

Equipment Class: Commercial, Residential, & Light
Industrial

Product Name: PCMCIA Card

Model Number : SSP-200/300

Table of Contents

1 . Introduction	1-1
2 . DOS / Windows 3.x Installation	2-1
2.1 SSP-200/300 Client Driver for DOS	1-2
2.1.1 Client Driver Installation	1-2
2.1.2 Command Line Options	2-3
2.1.3 Common Problems	1-8
2.2 SSP-200/300 Enabler for DOS	2-9
2.2.1 Command Line Options	1-10
2.2.2 Common Problems	1-14
3 . Windows 95/98/Millennium (ME)	3-1
3.1 Installing a SSP-200/300 Under Windows 95/98/ME	3-1
3.2 SSP-200/300 Resource Settings in Windows 95/98/ME	3-1
3.3 Viewing Resource Settings with Device Manager	3-2
3.4 Changing Resource Settings with Device Manager	3-2
3.5 Frequently Asked Questions	3-5
4 Windows 2000	3-6
4.1 Installing a SSP-200/300 Under Windows 2000.	3-6
4.2 SSP-200/300 Resource Settings in Windows 2000	3-6
4.2.1 Viewing Resource Settings with Device Manager	3-7
4.2.2 Changing Resource Settings with Device Manager	3-7
5 Windows NT	3-10
5.1 Installing SSP-200/300	3-10
6 . Hardware Information	3-14
6.1 Auxiliary Channel Configuration	3-14
6.1.1 Auxiliary Channel: RTS-CTS Handshaking.	3-14
6.1.2 Auxiliary Channel: Handshaking Disabled.	3-15
6.2 Half Duplex Operation	3-16
6.3 Termination Resistors	3-18
6.4 PCMCIA Configuration Register	3-19
7 . External Connections	6-1
8 . Specifications	7-1

List of Figures

Figure 1. SSP-200/300 Card and Cable Assembly	1-1
Figure 2. Client Driver versus Enabler for DOS/Windows 3.x.	2-1
Figure 3. DOS Client Output Enable Options.	2-3
Figure 4. DOS Enabler Output Enable Options.	2-11
Figure 9. Auxiliary Channel RTS-CTS Handshaking	3-14
Figure 10. Auxiliary Channel Handshaking Disabled	3-15
Figure 11. RS-422/485 Driver Enable Options	3-16
Figure 12. RS-422/485 Termination	3-18
Figure 13. PCMCIA Configuration Options Register	3-19
Figure 14. SSP-200/300 Adapter Cable.	6-1
Figure 15. RS-422/485 Signal Assignment.	6-1

1. Introduction

The SSP-200/300 is a single channel RS-422/RS-485 asynchronous serial adapter for systems equipped with PCMCIA Type II and/or Type III expansion sockets. The SSP-200/300 is a PCMCIA Type II (5 mm) card and is PCMCIA PC Card Standard Specification 2.1 compliant.

The SSP-200/300's serial port is implemented using a 16C750 Universal Asynchronous Receiver/Transmitter (UART), which is the recommended communications interface for multitasking environments and with applications involving high data transfer rates.

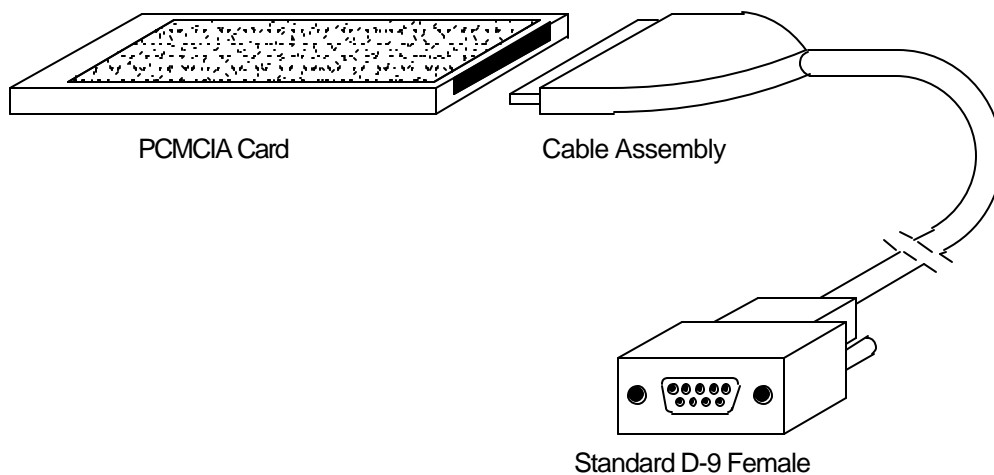

Figure 1. SSP-200/300 Card and Cable Assembly

The SSP-200/300 provides four differential signal pairs (two input and two output): TxD, RxD, AUXOUT, and AUXIN. TxD and RxD are always present at the connector. The AUXOUT and AUXIN signals can be used to support RTS/CTS handshaking, external clocking, or external signal loopback. The default configuration is RTS/CTS handshaking, with RTS transmitted through AUXOUT and CTS received through AUXIN. The role of AUXOUT and AUXIN can be set when the SSP-200/300 is configured.

The SSP-200/300 may be configured to operate in either the Full Duplex or Half Duplex mode; the SSP-200/300 may be configured so that the output drivers are always enabled, RTS or DTR enable the output drivers, or the output drivers are automatically enabled only when data is being transmitted. See the **Hardware Information** section for details on these topics.

(This page intentionally left blank.)

2. DOS / Windows 3.x Installation

Two configuration software programs are provided with the SSP-200/300: a Client Driver, and a card Enabler. Both of these programs are executed from DOS (before entering Windows) and allow operation of the SSP-200/300 in both the DOS and Windows 3.x environments. For optimal operation, however, the Client Driver is the preferred method of installation and configuration. The table below highlights the differences between these programs.

Client Driver (recommended)	Enabler
File type: DOS device driver	File type: DOS executable
Interfaces to PCMCIA Card and Socket Services software (PCMCIA host adapter independent)	Interfaces directly to Intel 82365SL and other PCIC compatible PCMCIA host adapters
Allows automatic configuration of SSP-200/300 adapters upon insertion (Hot Swapping)	Does not support automatic configuration of adapters upon insertion (Hot Swapping)
Requires PCMCIA Card and Socket Services software	Does not require PCMCIA Card and Socket Services software

Figure 2. Client Driver versus Enabler for DOS/Windows 3.x.

Card and Socket Services software is commercially available from several vendors for most desktop and laptop PCs. If you are unsure whether Card and Socket Services software is currently installed on your system, install the SSP-200/300 Client Driver as discussed in following section. When loaded, the Client Driver will display an error message if Card and Socket Services software is not detected.

2.1 SSP-200/300 Client Driver for DOS

In order to use the SSP-200/300 Client Driver, the system must be configured with Card and Socket Services software. Card and Socket Services software is not provided with the SSP-200/300 but is available from Quatech.

IMPORTANT:

Some versions of Card and Socket Services dated before 1993 do not support general purpose I/O cards. If after careful installation of the Client Driver the adapter does not configure or operate properly, an updated version of Card and Socket Services may be required.

2.1.1 Client Driver Installation

The following procedure is used to install the SSP-200/300 Client Driver:

1. Copy the Client Driver from the SSP-200/300 distribution diskette onto the system's hard drive.
2. Using an ASCII text editor, open the system's CONFIG.SYS file located in the root directory of the boot drive.
3. Locate the line(s) in the CONFIG.SYS file where the Card and Socket Services software is installed.
4. **AFTER** the line(s) installing the Card and Socket Services software, add the following line to the CONFIG.SYS file: `DEVICE = drive:\path\SSP230CL.SYS options`
where *options* are the SSP-200/300 Client Driver command line options discussed on the following pages.
5. Save the CONFIG.SYS file and exit the text editor.
6. Insert the SSP-200/300 into one of the system's PCMCIA slots.

NOTE: Since the SSP-200/300 Client Driver supports "Hot Swapping", it is not necessary to have the SSP-200/300 installed when booting the system. By inserting the card before booting, however, the Client Driver will report the adapter configuration during the boot process thereby verifying the changes made to the CONFIG.SYS.

7. Reboot the system and note the message displayed when the SSP-200/300 Client Driver is loaded. If the Client Driver reports an "invalid command line option", correct the entry in the CONFIG.SYS file and reboot the system again. If the Client Driver reports "Card and Socket Services not found", a version of Card and Socket Services must be installed on the system or the SSP-200/300 Enabler program must be used to configure the adapter. If the Client Driver reports the desired adapter configuration, the installation process is complete

and the SSP-200/300 may be removed and/ or inserted from the system as desired. On each insertion into the PCMCIA socket, the SSP-200/300 will be automatically reconfigured according to the command line options.

2.1.2 Command Line Options

The SSP-200/300 Client Driver accepts up to eight command line arguments from the user to determine the configuration of the SSP-200/300. If any arguments are provided, the Client Driver will attempt to configure any SSP-200/300s with the options specified in the order they are entered on the command line. Each argument must be enclosed in parenthesis and must be separated from other arguments by a **space** on the command line. Within each argument, any or all of the following parameters may be specified using a **comma (no spaces)** to separate each parameter:

Baddress specifies a the base I/O address of the SSP-200/300in hexadecimal. This address must reside on an even 8-byte boundary. If this option is omitted, a base address will be assigned by Card and Socket Services.

Iirq specifies the interrupt level (IRQ) of the SSP-200/300in decimal. *irq* must be one of the following values: 3, 4, 5, 7, 9, 10, 11, 12, 14, 15, or 0 if no IRQ is desired. If this option is omitted, an interrupt level will be assigned by Card and Socket Services.

Ssocket specifies which PCMCIA socket the SSP-200/300must be inserted into for this configuration argument to be used. *socket* must be in the range 0 - 15. If this option is omitted, the configuration argument will apply to SSP-200/300s inserted into any socket.

Odriver specifies RS-422/485 output driver enable option for the SSP-200/300 port. The SSP-200/300's port may be configured for either full duplex or half duplex operation with this option. If this option is omitted, the default setting is the RS-422/485 port is configured for full duplex operation with the RS-422/485 output drivers always enabled. In half duplex mode, the RS-422/485 transmitter may be enabled and disabled via the RTS (request to send) or DTR (data terminal ready) signals. Both RTS and DTR are controlled through the Modem Control Register of the 16750. See the **Hardware Information** section for more information.

Option	Port Output Driver
o0	Always Enabled
o1	DTR Controlled
o2	RTS Controlled

Figure 3. DOS Client Output Enable Options.

H instructs the client driver to enable the RTS-CTS modem control handshake on the RS-422/485 port. When modem control handshaking in enabled, the 16C750 UART's RTS and CTS signals are connected to the RS-422/485 auxiliary channel. The auxiliary

channel may then be used for handshaking between the SSP-200/300's port and a peripheral device. When modem control handshaking is disabled, the RTS and CTS signals from the 16C750 UART are looped back to each other. If this option is omitted, the default setting is RTS-CTS modem control handshake disabled. See the **Hardware Information** section for more information.

2.1.2.1 Example 1

DEVICE = C:\SSP-200\SSP230CL.SYS

In example 1, no command line arguments are specified. The Client Driver will configure a SSP-200/300 inserted into any socket with a base address and IRQ assigned by Card and Socket Services. The SSP-200/300 RS-422/485 output drivers will always be enabled, and RTS-CTS modem control handshaking will be disabled.

2.1.2.2 Example 2

DEVICE = C:\SSP-200\SSP230CL.SYS (b290,i11)

In example 2, a single command line argument is provided. The Client Driver will attempt to configure a SSP-200/300 inserted into any socket with a base address of 290H and IRQ 11. If address 290H or IRQ 11 is unavailable, the SSP-200/300 will not be configured. If the Client Driver can successfully configure the SSP-200/300 unit, the RS-422/485 output drivers will always be enabled, and RTS-CTS modem control handshaking will be disabled.

2.1.2.3 Example 3

DEVICE = C:\SSP-200\SSP230CL.SYS(s0,b300,i5,o2)

In example 3, a single command line argument is provided. The Client Driver will attempt to configure a SSP-200/300 inserted into socket 0 with a base address of 300H and IRQ 5. If address 300H or IRQ 5 is unavailable, the SSP-200/300 will not be configured. In addition, if a SSP-200/300 is inserted into any other socket, it will not be configured. If the Client Driver can successfully configure the SSP-200/300, the RS-422/485 output drivers will be enabled and disabled via the RTS signal, and RTS-CTS modem control handshaking will be disabled.

2.1.2.4 Example 4

```
DEVICE = C:\SSP-200\SSP230CL.SYS(i5,h,b300)
```

In example 4, a single command line argument is provided. Because the parameter order is not significant, the Client Driver will attempt to configure a SSP-200/300 inserted into any socket with a base address of 300H and IRQ 5. If address 300H or IRQ 5 is unavailable, the SSP-200/300 will not be configured. If the Client Driver can successfully configure the SSP-200/300, the RS-422/485 output drivers will always be enabled, and RTS-CTS modem control handshaking will be enabled on the RS-422/485 port's auxiliary channel.

2.1.2.5 Example 5

```
DEVICE = C:\SSP-200\SSP230CL.SYS (b300,i5) (i10) ( )
```

In example 5, three command line arguments are provided. The Client Driver will first attempt to configure a SSP-200/300 inserted into any socket with a base address of 300H and IRQ 5. If address 300H or IRQ 5 is unavailable, the Client Driver will proceed to the second command line argument and attempt to configure the card with a base address assigned by Card and Socket Services and IRQ 10. If IRQ 10 is also unavailable, the Client Driver will proceed to the third command line argument and attempt to configure the SSP-200/300 with a base address and an IRQ assigned by Card and Socket Services. If the Client Driver can successfully configure the SSP-200/300, the RS-422/485 output drivers for will always be enabled, and RTS-CTS modem control handshaking will be disabled.

2.1.2.6 Example 6

```
DEVICE = C:\SSP-200\SSP230CL.SYS (b300,i5) ( ) (i10)
```

In example 6, the three command line arguments of example 5 have been rearranged. The Client Driver will first attempt to configure a SSP-200/300 inserted into any socket with a base address of 300H and IRQ 5. If address 300H or IRQ 5 is unavailable, the Client Driver will proceed to the second command line argument and attempt to configure the card with a base address and IRQ assigned by Card and Socket Services. Since the second command line argument includes all available address and IRQ resources, the third command line argument will never be reached by the Client Driver. It is the user's responsibility to place the command line arguments in a logical order.

2.1.2.7 Example 7

```
DEVICE = C:\SSP-200\SSP230CL.SYS (s0,b300,i5) (s1,b340,i10)
```

The type of configuration shown in example 7 may be desirable in systems where more than one SSP-200/300 is to be installed. In this example, the Client Driver will attempt to configure a SSP-200/300 inserted into socket 0 with a base address of 300H and IRQ 5. If the SSP-200/300 is inserted into socket 1, the Client Driver will attempt to configure it with base address 340H and IRQ 10. This allows the user to force the SSP-200/300's address and IRQ settings to be socket specific which may simplify cable connections and software development. As in the previous examples, however, if the requested address or interrupt resources are not available, the SSP-200/300 will not be configured.

2.1.3 Common Problems

Generic Client Drivers:

Many Card and Socket Services packages include a generic client driver (or SuperClient) which configures standard I/O devices. If one of these generic client drivers is installed, it may configure the SSP-200/300 causing the SSP-200/300 client driver to fail installation. In these cases, the user should do one of the following:

1. Modify the operation of the generic client driver to disable the configuration of modem/serial port cards. Consult the Card and Socket Services documentation for availability and details of this feature.
2. Place the SSP-200/300 client driver before the generic client driver in the CONFIG.SYS.

Available Resources:

One function of the Card and Socket Services software is to track which system resources (memory addresses, I/O addresses, IRQs, etc.) are available for assignment to inserted PCMCIA cards. Sometimes, however, the Card Services software assumes or incorrectly determines that a particular resource is used when it is actually available. Most Card and Socket Services generate a resource table in a file (typically in the form of an .INI file) which the user can modify to adjust the available system resources. Consult the Card and Socket Services documentation for availability and details of this feature.

Multiple Configuration Attempts:

Some Card and Socket Services have a setting which aborts the configuration process after a single configuration failure (such as a request for an unavailable resource). The user should change this setting to allow for multiple configuration attempts. Consult the Card and Socket Services documentation for availability and details of this feature.

Older Versions of Card and Socket Services:

Some versions of Card and Socket Services dated before 1993 do not support general purpose I/O cards. If after careful installation of the Client Driver the SSP-200/300 does not configure or operate properly, an updated version of Card and Socket Services may be required. Card and Socket Services software is available from Quatech.

2.2 SSP-200/300 Enabler for DOS

For systems that are not operating PCMCIA Card and Socket Services software, the SSP-200/300 DOS Enabler may be used to enable and configure the adapter. This Enabler, SSP200EN.EXE, will operate on any DOS system using an Intel 82365SL or PCIC compatible PCMCIA host adapter including the Cirrus Logic CL-PD6710 /6720, the VLSI VL82C146, and the Vadem VG-365 among others.

IMPORTANT:

In order to use the SSP-200/300 Enabler for DOS, the system MUST NOT be configured with Card and Socket Services software. If a Card and Socket Services software is installed, the SSP-200/300 Enabler may interfere with its operation and with the device(s) it controls.

The SSP-200/300 Enabler does not support automatic configuration of adapters upon insertion, more commonly referred to as "Hot Swapping". This means the adapter must be installed in one of the system's PCMCIA sockets before executing SSP200EN.EXE. If more than one adapter is installed in a system, the Enabler must be executed separately for each adapter. Furthermore, SSP200EN.EXE should be executed to release the resources used by the adapter before it is removed from the PCMCIA socket. Since PCMCIA adapters do not retain their configuration after removal, any adapter that is removed from the system must be reconfigured with the Enabler after re-inserting it into a PCMCIA socket.

IMPORTANT:

The Enabler requires a region of high DOS memory when configuring a SSP-200/300. This region is 1000H bytes (4KB) long and by default begins at address D0000H (the default address may be changed using the "W" option). If a memory manager such as EMM386, QEMM, or 386Max is installed on the system, this region of DOS memory must be excluded from the memory manager's control. Consult the documentation provided with the memory manager software for instructions on how to exclude this memory region.

2.2.1 Command Line Options

To configure a SSP-200/300 in the system, the Enabler requires one command line argument from the user to determine the configuration of the card. This argument must be enclosed in parenthesis and within the argument, any or all of the following parameters may be specified using a comma (no spaces) to separate each parameter:

Ssocket specifies which PCMCIA socket the SSP-200/300 must be inserted into for this configuration argument to be used. *socket* must be in the range 0 - 15. This option is required if the 'R' option is not used.

Baddress specifies the base I/O address of the SSP-200/300 in hexadecimal. This address must reside on an even 8-byte boundary. This option is required if the 'R' option is not used.

Iirq specifies the interrupt level (IRQ) of the SSP-200/300 in decimal. *irq* must be one of the following values: 3, 4, 5, 7, 9, 10, 11, 12, 14, 15, or 0 if no IRQ is desired. This option is required if the 'R' option is not used.

Waddress specifies the base address of the memory window required to configure the SSP-200/300. Set *address* = D0 for a memory window at segment D000, *address* = D8 for a memory window at segment D800, etc. Valid settings for *address* are C8, CC, D0, D4, D8, and DC. If this option is omitted, a memory window at segment D000 will be used.

Odriver specifies RS-422/485 output driver enable option for the SSP-200/300. The SSP-200/300's port may be configured for either full duplex or half duplex operation with this option. If this option is omitted, the default setting is the RS-422/485 port is configured for full duplex operation with the RS-422/485 output drivers always enabled. In half duplex mode, the RS-422/485 transmitter may be enabled and disabled via the RTS (request to send) or DTR (data terminal ready) signals. Both RTS and DTR are controlled through the Modem Control Register of the 16750. See the **Hardware Information** section for more information.

Option	Output Driver
o0	Always Enabled
o1	DTR Controlled
o2	RTS Controlled
o3	Auto-toggle

Figure 4. DOS Enabler Output Enable Options.

H instructs the enabler to enable the RTS-CTS modem control handshake on the RS-422/485 port. When modem control handshaking is enabled, the 16C750 UART's RTS and CTS signals are connected to the RS-422/485 auxiliary channel. The auxiliary channel may then be used for handshaking between the SSP-200/300's RS-422/485 port and a peripheral device. When modem control handshaking is disabled, the RTS and CTS signals from the 16C750 UART are looped back to each other. If this option is omitted, the default setting is RTS-CTS modem control handshake disabled. See the **Hardware Information** section for more information .

Before removing a SSP-200/300 from its PCMCIA socket, the Enabler should be executed to free the system resources allocated when the card was installed. For this operation the Enabler provides on additional command line option:

R instructs the enabler to release the resources previously allocated to the SSP-200/300. When the 'R' option is used, any settings specified by the 'B', 'T', 'O', and 'H' options are ignored.

2.2.1.1 Example 1

SSP230EN.EXE

In example 1, no command line argument is specified. The Enabler will report an error and display the proper usage of the command.

2.2.1.2 Example 2

SSP230EN.EXE (s0,b300,i5)

In example 2, the Enabler will configure the SSP-200/300 in socket 0 with a base address of 300H and IRQ 5 using a configuration memory window at segment D000. The SSP-200/300 unit's RS-422/485 output drivers will always be enabled, and RTS-CTS modem control handshaking will be disabled.

2.2.1.3 Example 3

SSP230EN.EXE (i10,h,b340,s1)

In example 3, the Enabler will configure the SSP-200/300 in socket 1 with a base address of 340H and IRQ 10 using a configuration memory window at segment D000. The SSP-200/300's RS-422/485 output drivers will always be enabled, and RTS-CTS modem control handshaking will be enabled on the RS-422/485 auxiliary channel.

2.2.1.4 Example 4

SSP230EN.EXE (s0,b300,i3,wd8)

In example 4, the Enabler will configure the SSP-200/300 in socket 0 with a base address of 300H and IRQ 3 using a configuration memory window at segment D800. The SSP-200/300's RS-422/485 output drivers will always be enabled, and RTS-CTS modem control handshaking will be disabled

2.2.1.5 Example 5

SSP230EN.EXE (o1,i5,b340,s1)

In example 2, the Enabler will configure the SSP-200/300 in socket 1 with a base address of 340H and IRQ 5 using a configuration memory window at segment D000. The SSP-200/300's RS-422/485 output drivers will be enabled and disabled via the DTR signal, and RTS-CTS modem control handshaking will be disabled

2.2.1.6 Example 6

SSP230EN.EXE (s0,b300,i5,r)

In example 6, the Enabler will release the configuration used by the SSP-200/300 in socket 0 using a configuration memory window at segment D000. The base address and IRQ parameters are ignored and may be omitted.

2.2.1.7 Example 7

SSP230EN.EXE (s1,r,wcc)

In example 7, the Enabler will release the configuration used by the SSP-200/300 in socket 1 using a configuration memory window at segment CC00.

2.2.2 Common Problems

Memory Range Exclusion:

The Enabler requires a region of high DOS memory when configuring aSSP-200/300. This region is 1000H bytes (4KB) long and by default begins at address D0000H (the default address may be changed using the "W" option). If a memory manager such as EMM386, QEMM, or 386Max is installed on the system, this region of DOS memory must be excluded from the memory manager's control. Consult the documentation provided with the memory manager software for instructions on how to exclude this memory region.

Furthermore, some systems use the high memory area for BIOS shadowing to improve overall system performance. In order for the Enabler to operate, any BIOS shadowing must be disabled in the address range specified for the configuration window. BIOS shadowing can usually be disabled through the system's CMOS setup utility.

Socket Numbers:

The Enabler requires the SSP-200/300's socket number to be specified on the command line and the SSP-200/300 must be inserted into the socket before the Enabler is invoked. Some vendors number their sockets from 1 to N while other vendors number their sockets from 0 to N-1. For the SSP-200/300 Enabler, the lowest socket number in the system is designated socket 0.

Card and Socket Services Software:

In order to use the SSP-200/300 Enabler for DOS, the system MUST NOT be configured with Card and Socket Services software. If a Card and Socket Services software is installed, the Enabler may interfere with its operation and with the device(s) it controls. For systems configured with Card and Socket Services, the SSP-200/300 Client Driver is the recommended method of configuration.

3. Windows 95/98/Millennium (ME)

To allow easy configuration of the SSP-200/300, an Windows 95/98/ME "INF" configuration file has been written for the hardware. It supports the AUXIN/AUXOUT options and the RS-422/485 output driver enable options for full and half duplex operation.

3.1 Installing a SSP-200/300 Under Windows 95/98/ME

1. Insert the SSP-200/300 into any available PC Card socket.
2. The first time a new PC Card type is installed the **New Hardware Found** window opens. After this first installation Windows **95/98/ME** will automatically detect and configure the card. If the **New Hardware Found** window does not open, then skip to the next section, "SSP-200/300 Resource Settings".
3. The **New Hardware Found** window provides several options to configure the SSP-200/300 card. Click the "**Search for the best driver for your device**" option button. Click "NEXT" to continue.
4. An "**Install from Disk**" dialog box should appear. Insert the Quatech COM CD file, select the correct drive letter and path, and click "OK". Windows 95/98/ME will browse the path for the aforementioned files.
5. During the installation process, it may be required to supply the computer with the Windows 95/98/ME CD or installation CDs. Insert the CD and click "OK".

The SSP-200/300 PC Card should now be configured. With the default configuration, the SSP-200/300's interrupt status register will be enabled, the 16C750 UART's scratchpad register will be disabled, the RS-422/485 output drivers will always be enabled, and RTS-CTS modem control handshaking will be enabled. In the future, Windows 95/98/ME will automatically recognize and configure the SSP-200/300 in this default configuration.

3.2 SSP-200/300 Resource Settings in Windows 95/98/ME

Windows **95/98/ME** maintains a registry of all known hardware installed within the computer. Inside this hardware registry Windows **95/98/ME** keeps track of all the computer's resources, such as base I/O addresses, IRQ levels, and DMA channels. In the case of a **PC Card (PCMCIA)** type board, Windows **95/98/ME** configures the new hardware using free resources it finds within the hardware registry, and updates the registry automatically.

To view and/or edit hardware devices in Windows **95/98/ME** use the system **Device Manager**. To access Device Manager double click the **System** icon in the Windows **95/98/ME** control panel, or click the **My Computer** icon on the Windows **95/98/ME** desktop with the right mouse button and

select **Properties** from the pull down menu. Consult Windows **95/98/ME** on-line help for details on the use of the **Device Manager**.

3.3 Viewing Resource Settings with Device Manager

1. Start the Windows **95/98/ME Device Manager**.
2. Double click on the hardware class **Quatech Comm Adapters** to list hardware devices in the class.
3. The SSP-200/300 “parent device” belongs to this hardware class. The device name for the SSP-200/300 is **Quatech SSP-200/300: RS-422/RS-485 Serial Port PC Card**.
4. Open the **Properties** dialog for the SSP-200/300 device, then click the **Resources** tab to view the Input/Output Range and Interrupt Request resource allocations.
5. Double click the hardware class **Ports (Com and LPT)**. The **Quatech Communications Port** listed in this class is a “child device” of the SSP-200/300 “parent device.”
6. Open the **Properties** dialog for the COM port, then click the **Resources** tab to view the Input/Output Range and Interrupt Request resource allocations. These will match those of the “parent device.”
7. Record the COM Port device name (COM1, COM2, etc.) for the SSP-200/300. This name is required by a Windows **95/98/ME** application when accessing a particular port.

3.4 Changing Resource Settings with Device Manager

1. Start the Windows **95/98/ME Device Manager**.
 2. Double click on the hardware class **Quatech Comm Adapters** to list hardware devices in the class.
 3. The SSP-200/300 “parent device” belongs to this hardware class. The device name for the SSP-200/300 is **Quatech SSP-200/300: RS-422/RS-485 Serial Port PC Card**.
 4. Open the **Properties** dialog for the SSP-200/300 device, then click the **Resources** tab to view the Input/Output Range and Interrupt Request resource allocations.
 5. Several predefined **Basic Configurations** have been included for the SSP-200/300 (see Figure 5. SSP-200/300 Basic Configuration Table). The Basic Configurations provide many combinations of the operating modes and options listed below. See the **Hardware Information** section of this manual for complete descriptions.
- ✍ RS-422/485 output drivers enable option: The SSP-200/300’s ports may be configured for either full duplex or half duplex operation with this option. The default setting is the RS-422/485 ports are configured for full duplex operation with the RS-422/485 output drivers always enabled. In half duplex mode, the RS-422/485 transmitter may be enabled

and disabled via the RTS (request to send) or DTR (data terminal ready) signals, or set to enable only when data is being transmitted (auto-toggle). Both RTS and DTR are controlled through the Modem Control Register of the 16750.

When the **Use Automatic Settings** check box is enabled Windows 95/98/ME will attempt to configure the SSP-200/300 in the order listed in the Basic Configurations table.

Basic Configuration	RTS - CTS Handshaking**	I/O Range***	RS-422/485 Output Drivers	Clock Speed	Scratch Pad/ ISR
0000*	Handshaking	3F8-3FF	Always Enabled	Normal	ISR
0001*	Handshaking	2F8-2FF	Always Enabled	Normal	ISR
0002*	Handshaking	3E8-3EF	Always Enabled	Normal	ISR
0003*	Handshaking	2E8-2EF	Always Enabled	Normal	ISR
0004	Handshaking	Any	Always Enabled	Normal	ISR
0005	Handshaking	Any	Always Enabled	8x	ISR
0006	Handshaking	Any	Auto Toggle	Normal	ISR
0007	Handshaking	Any	RTS Controlled	Normal	ISR
0008	Handshaking	Any	DTR Controlled	Normal	ISR
0009	Loopback	Any	Always Enabled	Normal	ISR
000A	Clocking	Any	Always Enabled	Normal	ISR
000B	Handshaking	Any	Auto Toggle	8x	ISR
000C	Handshaking	Any	RTS Controlled	8x	ISR
000D	Handshaking	Any	DTR Controlled	8x	ISR
000E	Loopback	Any	Always Enabled	8x	ISR
000F	Clocking	Any	Always Enabled	8x	ISR
0010	Loopback	Any	Auto Toggle	Normal	ISR
0011	Clocking	Any	Auto Toggle	Normal	ISR
0012	Loopback	Any	RTS Controlled	Normal	ISR
0013	Clocking	Any	RTS Controlled	Normal	ISR
0014	Loopback	Any	DTR Controlled	Normal	ISR
0015	Clocking	Any	DTR Controlled	Normal	ISR
0016	Loopback	Any	Auto Toggle	8x	ISR
0017	Clocking	Any	Auto Toggle	8x	ISR
0018	Loopback	Any	RTS Controlled	8x	ISR
0019	Clocking	Any	RTS Controlled	8x	ISR
001A	Loopback	Any	DTR Controlled	8x	ISR
001B	Clocking	Any	DTR Controlled	8x	ISR
001C	Handshaking	Any	Always Enabled	Normal	Scratch Pad
001D	Handshaking	Any	Always Enabled	8x	Scratch Pad
001E	Handshaking	Any	Auto Toggle	Normal	Scratch Pad
001F	Handshaking	Any	RTS Controlled	Normal	Scratch Pad
0020	Handshaking	Any	DTR Controlled	Normal	Scratch Pad
0021	Loopback	Any	Always Enabled	Normal	Scratch Pad
0022	Clocking	Any	Always Enabled	Normal	Scratch Pad
0023	Handshaking	Any	Auto Toggle	8x	Scratch Pad
0024	Handshaking	Any	RTS Controlled	8x	Scratch Pad
0025	Handshaking	Any	DTR Controlled	8x	Scratch Pad
0026	Loopback	Any	Always Enabled	8x	Scratch Pad
0027	Clocking	Any	Always Enabled	8x	Scratch Pad
0028	Loopback	Any	Auto Toggle	Normal	Scratch Pad
0029	Clocking	Any	Auto Toggle	Normal	Scratch Pad
002A	Loopback	Any	RTS Controlled	Normal	Scratch Pad
002B	Clocking	Any	RTS Controlled	Normal	Scratch Pad
002C	Loopback	Any	DTR Controlled	Normal	Scratch Pad
002D	Clocking	Any	DTR Controlled	Normal	Scratch Pad
002E	Loopback	Any	Auto Toggle	8x	Scratch Pad
002F	Clocking	Any	Auto Toggle	8x	Scratch Pad

0030	Loopback	Any	RTS Controlled	8x	Scratch Pad
0031	Clocking	Any	RTS Controlled	8x	Scratch Pad
0032	Loopback	Any	DTR Controlled	8x	Scratch Pad
0033	Clocking	Any	DTR Controlled	8x	Scratch Pad

* Indicates "COM" mode addressing. Addresses 3F8, 2F8, 3E8, and 2E8 are the standard addresses for COM1, COM2, COM3, and COM4, respectively. Windows 95/98/ME enumerates any COM port at a non-standard address starting with COM5.

** Handshaking indicates RTS routed to AUXOUT, AUXINrouted to CTS, and TCLK routed to RCLK. Loopback indicates RTS routed to CTS, AUXINrouted to AUXOUT, and TCLK routed to RCLK. Clocking indicates RTS routed to CTS, AUXIN routed to RCLK, and TCLK routed to AUXOUT.

*** Any indicates variable value; this value may or may not be user selectable depending on platform.

6. Select a **Basic Configurations** that displays "No conflicts" in the bottom display region titled **Conflicting Device List** from the drop down list. Some applications may not be able to access ports higher than COM4. To use the SSP-200/300 PCMCIA serial ports with these applications you might be forced to remove other serial communications devices from your system
7. To modify the **Interrupt Request** setting click the resource name and click the **Change Setting** button. An Edit Resource window will open up. Inside this window click on the up/down arrows to the right of the Interrupt Request value. This scrolls you through all of the allowable resources for your hardware. Pay attention to the conflict information at the bottom of the window. Do not select a value that causes a conflict with any other installed hardware.
8. If any changes have been made to the SSP-200/300's configuration the card will automatically be reconfigured to the new resources specified. Any time a PCMCIA card of this type is inserted Windows 95/98/ME will attempt to configure the card at these resource settings. Click the **Use Automatic Settings** box to reset this card type for automatic configuration.

3.5 Frequently Asked Questions

Basic Configuration List Not Available:

A problem noted on some systems is after a basic configuration has been manually selected the basic configurations list for the SSP-200/300 is no longer available. The solution to this problem is to check the "Use Automatic Settings" box and allow Windows 95/98/ME to reconfigure the SSP-200/300 card. The basic configurations list should once again be visible.

Base I/O Address Resource Modification Not Allowed:

The SSP-200/300 is configured to allow only a fixed number of base I/O addresses. To change the I/O address resources for the SSP-200/300 select another "Basic Configuration". Refer to the Basic Configurations table for a list of the available I/O address resources for the SSP-200/300

4 Windows 2000

To allow easy configuration of the SSP-200/300, an Windows 2000 "INF" configuration file has been written for the hardware. This configuration file supports the SSP-200/300 in both addressing modes: block mode and "com" mode. Additionally, the RTS-CTS modem control handshake option and the RS-422/485 output driver enable option for full and half duplex operation is supported.

4.1 Installing a SSP-200/300 Under Windows 2000.

1. Insert the Quatech COM CD into an available CD-ROM.
2. Insert the SSP-200/300 into any available PC Card socket.

Windows 2000 will automatically search the Quatech COM CD and install the proper INF file for the SSP-200/300

4.2 SSP-200/300 Resource Settings in Windows 2000

Windows 2000 maintains a registry of all known hardware installed within the computer. Inside this hardware registry Windows 2000 keeps track of all the computer's resources, such as base I/O addresses, IRQ levels, and DMA channels. In the case of a **PC Card (PCMCIA)** type board, Windows 2000 configures the new hardware using free resources it finds within the hardware registry, and updates the registry automatically.

To view and / or edit hardware devices in Windows 2000 use the system **Device Manager**. To access Device Manager double click the **System** icon in the Windows 2000 control panel, or click the **My Computer** icon on the Windows 2000 desktop with the right mouse button and select **Properties** from the pull down menu. Click on the **Hardware** tab then click on the **Device Manager**. Consult Windows 2000 on-line help for details on the use of the **Device Manager**.

Windows 2000 handles the SSP-200/300 as a "parent/child device".

- v The SSP-200/300 is the "parent device" and is listed under the hardware class **Quatech Multiport Serial Devices** in the device manager.
- v The serial port is a "child device" of the "parent device" SSP-200/300 (Quatech PCMCIA Serial Port). There is 1 child COM port for the SSP-200/300 (Quatech PCMCIA Serial Port) which is listed under the hardware class **Ports (Com & LPT)**.
- v

4.2.1 Viewing Resource Settings with Device Manager

1. Start the Windows 2000 **Device Manager**.
2. Double click on the hardware class **Quatech Multiport Serial Devices** to list hardware devices in the class.
3. The SSP-200/300 “parent device” belongs to this hardware class. The device name for the SSP-200/300 is **Quatech SSP-200/300 PCMCIA RS-422/RS-485 Serial Adapter**.
4. Open the **Properties** dialog for the SSP-200/300 device, then click the **Resources** tab to view the Input/Output Range and Interrupt Request resource allocations. Examine and remember the Input/Output Range, then close the properties window.
5. Double click the hardware class **Ports (Com and LPT)**. The **Quatech PCMCIA Serial Port** listed in this class is the “child device” of the SSP-200/300 “parent device.”
6. Use the COM Port device names (COM5, COM6, etc.) to access any of the particular serial ports on the SSP-200/300. This name is required by a Windows **2000** application when accessing a particular port

4.2.2 Changing Resource Settings with Device Manager

1. Start the Windows 2000 **Device Manager**.
2. Double click on the hardware class **Quatech Multiport Serial Devices** to list hardware devices in the class.
3. The SSP-200/300 “parent device” belongs to this hardware class. The device name for the SSP-200/300 is **Quatech SSP-200/300 PCMCIA RS-422/RS-485 Serial Adapter**.
4. Open the **Properties** dialog for the SSP-200/300 device, then click the **Resources** tab to view the Input/Output Range and Interrupt Request resource allocations.
5. Select a **Basic Configurations** that displays "No conflicts" in the bottom display region titled **Conflicting Device List** from the drop down list. Some applications may not be able to access ports higher than COM6. To use the SSP-200/300 PCMCIA serial ports with these applications you might be forced to remove other serial communications devices from your system.

Basic Configuration	RTS - CTS Handshaking**	I/O Range***	RS-422/485 Output Drivers	Clock Speed	Scratch Pad/ ISR
0000*	Handshaking	3F8-3FF	Always Enabled	Normal	ISR
0001*	Handshaking	2F8-2FF	Always Enabled	Normal	ISR
0002*	Handshaking	3E8-3EF	Always Enabled	Normal	ISR
0003*	Handshaking	2E8-2EF	Always Enabled	Normal	ISR
0004	Handshaking	Any	Always Enabled	Normal	ISR
0005	Handshaking	Any	Always Enabled	8x	ISR
0006	Handshaking	Any	Auto Toggle	Normal	ISR
0007	Handshaking	Any	RTS Controlled	Normal	ISR
0008	Handshaking	Any	DTR Controlled	Normal	ISR
0009	Loopback	Any	Always Enabled	Normal	ISR
0010	Clocking	Any	Always Enabled	Normal	ISR
0011	Handshaking	Any	Auto Toggle	8x	ISR
0012	Handshaking	Any	RTS Controlled	8x	ISR
0013	Handshaking	Any	DTR Controlled	8x	ISR
0014	Loopback	Any	Always Enabled	8x	ISR
0015	Clocking	Any	Always Enabled	8x	ISR
0016	Loopback	Any	Auto Toggle	Normal	ISR
0017	Clocking	Any	Auto Toggle	Normal	ISR
0018	Loopback	Any	RTS Controlled	Normal	ISR
0019	Clocking	Any	RTS Controlled	Normal	ISR
0020	Loopback	Any	DTR Controlled	Normal	ISR
0021	Clocking	Any	DTR Controlled	Normal	ISR
0022	Loopback	Any	Auto Toggle	8x	ISR
0023	Clocking	Any	Auto Toggle	8x	ISR
0024	Loopback	Any	RTS Controlled	8x	ISR
0025	Clocking	Any	RTS Controlled	8x	ISR
0026	Loopback	Any	DTR Controlled	8x	ISR
0027	Clocking	Any	DTR Controlled	8x	ISR
0028	Handshaking	Any	Always Enabled	Normal	Scratch Pad
0029	Handshaking	Any	Always Enabled	8x	Scratch Pad
0030	Handshaking	Any	Auto Toggle	Normal	Scratch Pad
0031	Handshaking	Any	RTS Controlled	Normal	Scratch Pad
0032	Handshaking	Any	DTR Controlled	Normal	Scratch Pad
0033	Loopback	Any	Always Enabled	Normal	Scratch Pad
0034	Clocking	Any	Always Enabled	Normal	Scratch Pad
0035	Handshaking	Any	Auto Toggle	8x	Scratch Pad
0036	Handshaking	Any	RTS Controlled	8x	Scratch Pad
0037	Handshaking	Any	DTR Controlled	8x	Scratch Pad
0038	Loopback	Any	Always Enabled	8x	Scratch Pad
0039	Clocking	Any	Always Enabled	8x	Scratch Pad
0040	Loopback	Any	Auto Toggle	Normal	Scratch Pad
0041	Clocking	Any	Auto Toggle	Normal	Scratch Pad
0042	Loopback	Any	RTS Controlled	Normal	Scratch Pad
0043	Clocking	Any	RTS Controlled	Normal	Scratch Pad
0044	Loopback	Any	DTR Controlled	Normal	Scratch Pad
0045	Clocking	Any	DTR Controlled	Normal	Scratch Pad
0046	Loopback	Any	Auto Toggle	8x	Scratch Pad
0047	Clocking	Any	Auto Toggle	8x	Scratch Pad

0048	Loopback	Any	RTS Controlled	8x	Scratch Pad
0049	Clocking	Any	RTS Controlled	8x	Scratch Pad
0050	Loopback	Any	DTR Controlled	8x	Scratch Pad
0051	Clocking	Any	DTR Controlled	8x	Scratch Pad
0052	Handshaking	Memory Mapped	Always Enabled	1x	Scratch Pad

* Indicates "COM" mode addressing. Addresses 3F8, 2F8, 3E8, and 2E8 are the standard addresses for COM1, COM2, COM3, and COM4, respectively. Windows 95/98/ME enumerates any COM port at a non-standard address starting with COM5.

** Handshaking indicates RTS routed to AUXOUT, AUXINrouted to CTS, and TCLK routed to RCLK. Loopback indicates RTS routed to CTS, AUXINrouted to AUXOUT, and TCLK routed to RCLK. Clocking indicates RTS routed to CTS, AUXIN routed to RCLK, and TCLK routed to AUXOUT.

*** Any indicates variable value; this value may or may not be user selectable depending on platform.

6. Windows 2000 should have chosen an available **Interrupt Request** setting automatically when the I/O address range was configured by a Basic Configuration selection. This default **Interrupt Request** setting should not need changed as long as "No conflicts" is displayed in the bottom display region titled **Conflicting Device List**. If you are satisfied with Windows 2000 selection then skip the next step
7. To modify the **Interrupt Request** setting click the resource name and click the **Change Setting** button. An Edit Resource window will open up. Inside this window click on the up/down arrows to the right of the Interrupt Request value. This scrolls you through all of the allowable resources for your hardware. Pay attention to the conflict information at the bottom of the window. Do not select a value that causes a conflict with any other installed hardware.
8. If any changes have been made to the SSP-200/300's configuration the card will automatically be reconfigured to the new resources specified. Any time a PCMCIA card of this type is inserted Windows 2000 will attempt to configure the card at these resource settings. Click the **Use Automatic Settings** box to reset this card type for automatic configuration

5 Windows NT

5.1 Installing SSP-200/300

To allow easy configuration of the SSP-200/300 the Quatech Device Manager for Windows NT has been written for the hardware.

To begin the installation, open Windows Explorer and search for the 'Setup.exe' command to install the Quatech Device Manager. <See following Windows Explorer figure.> (D:\Serial Port Adapters\Drivers\Windows NT 4.0 for PCI, PCMCIA,ISA). Once the installation is complete an icon will be placed on the desktop.

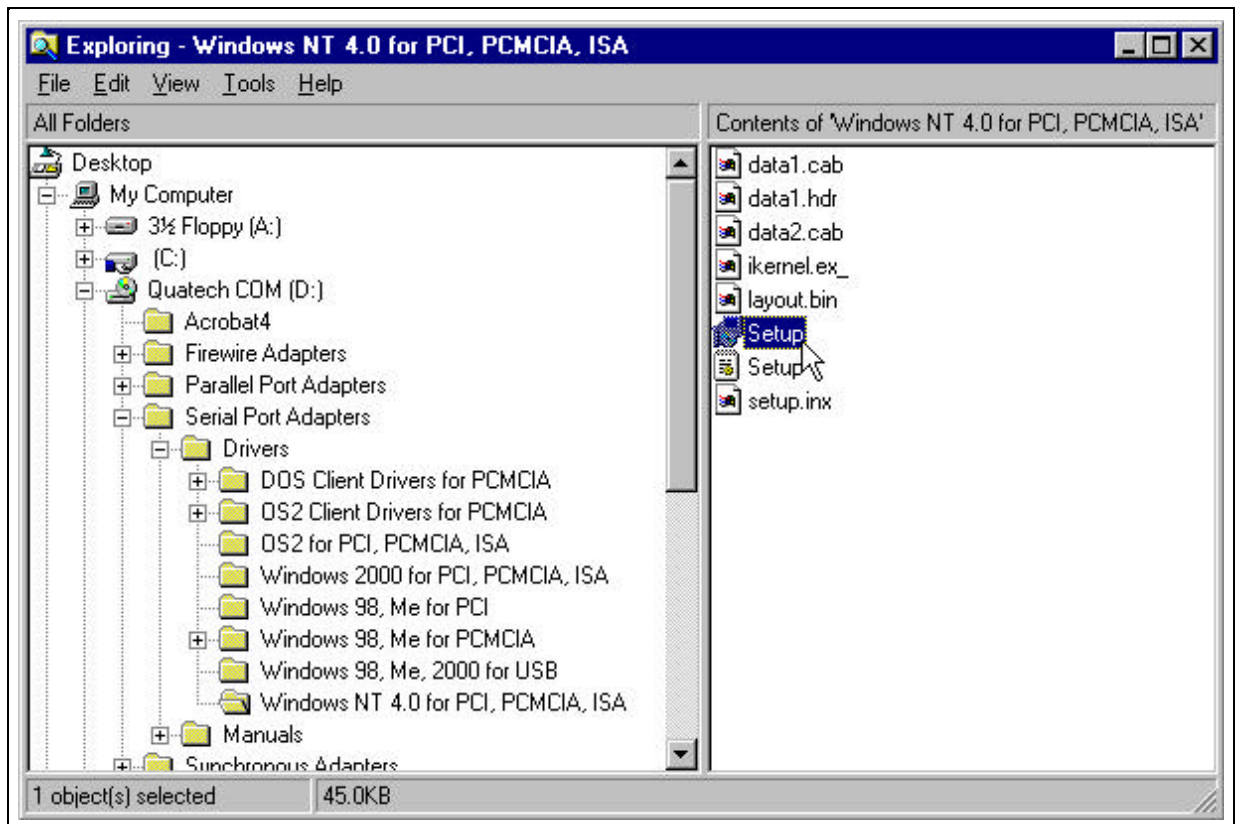

Windows NT Explorer

1. Locate and double click the Quatech Device Manager icon on the desktop

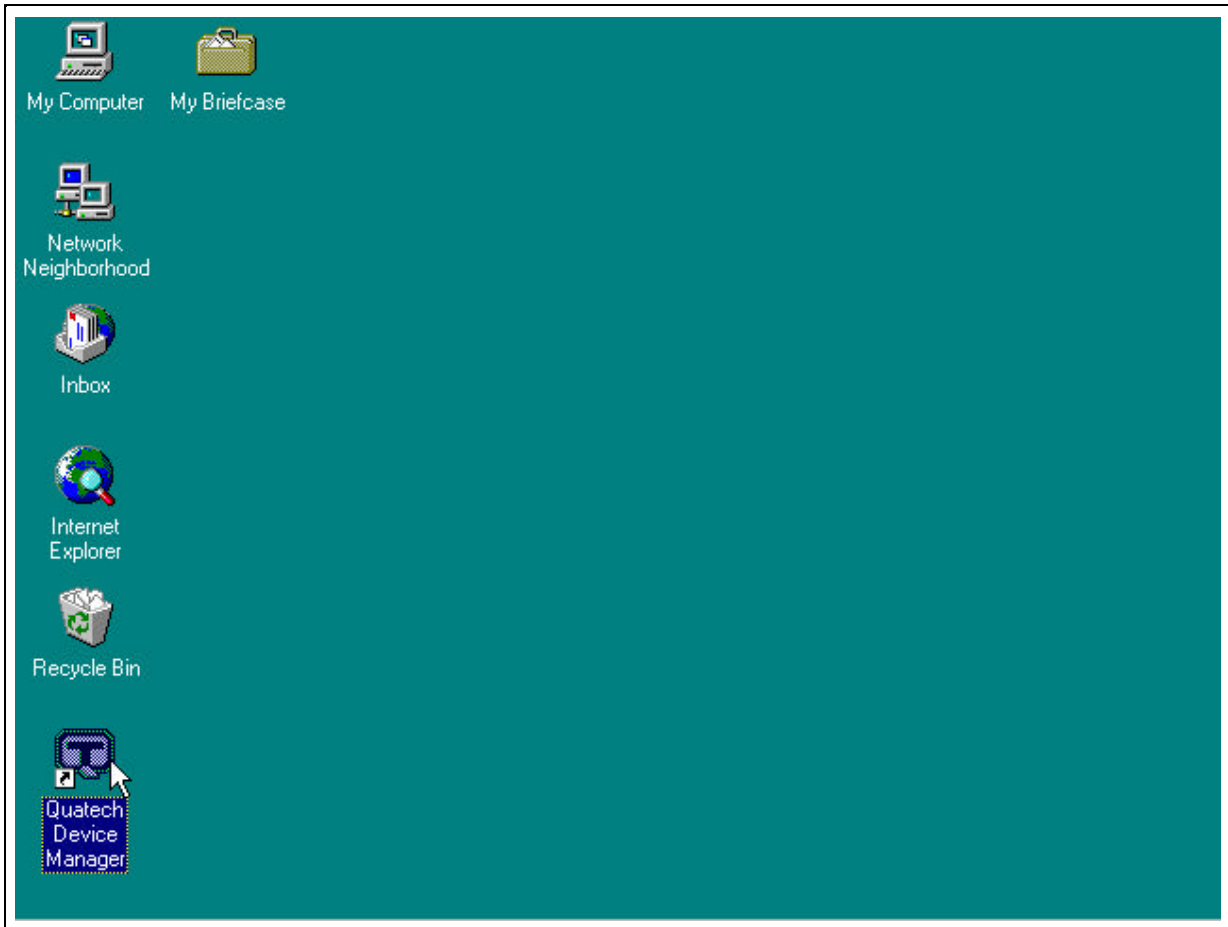

Device Manager Icon on Desktop

2. Click the 'Add' button at the bottom of the Quatech Device Manager Window

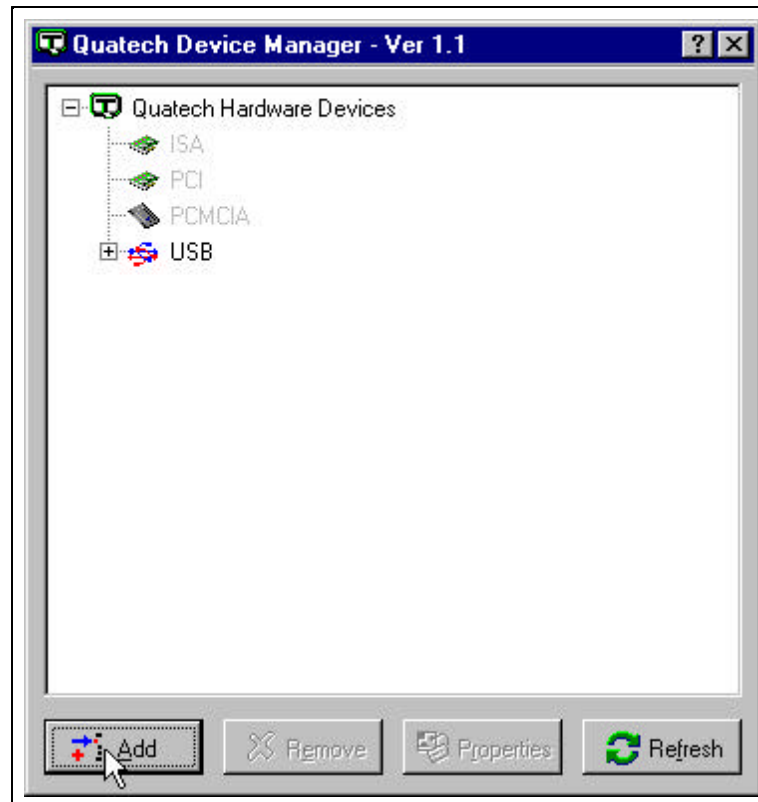

3. Follow the steps for the 'Add Quatech Hardware Wizard'.

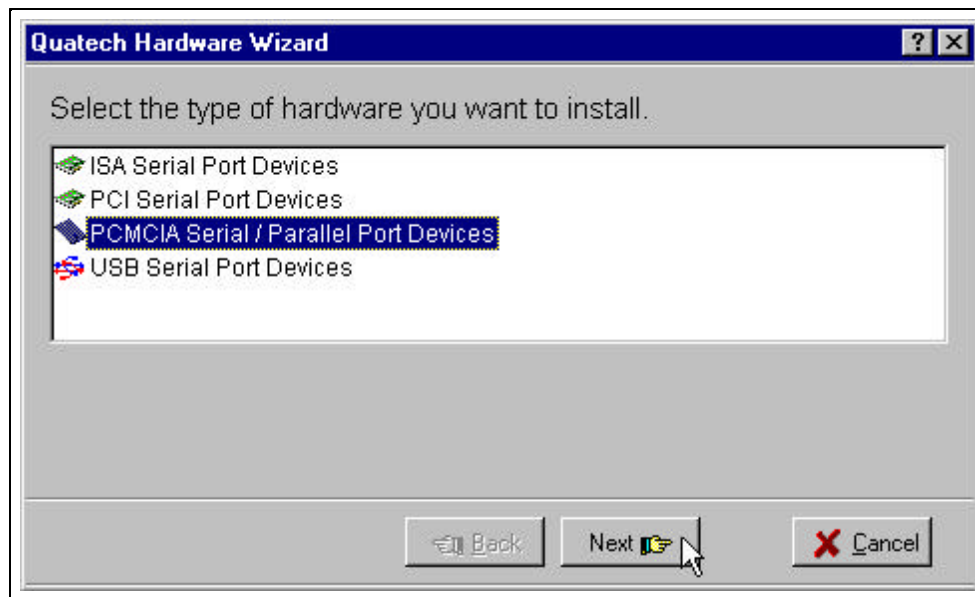

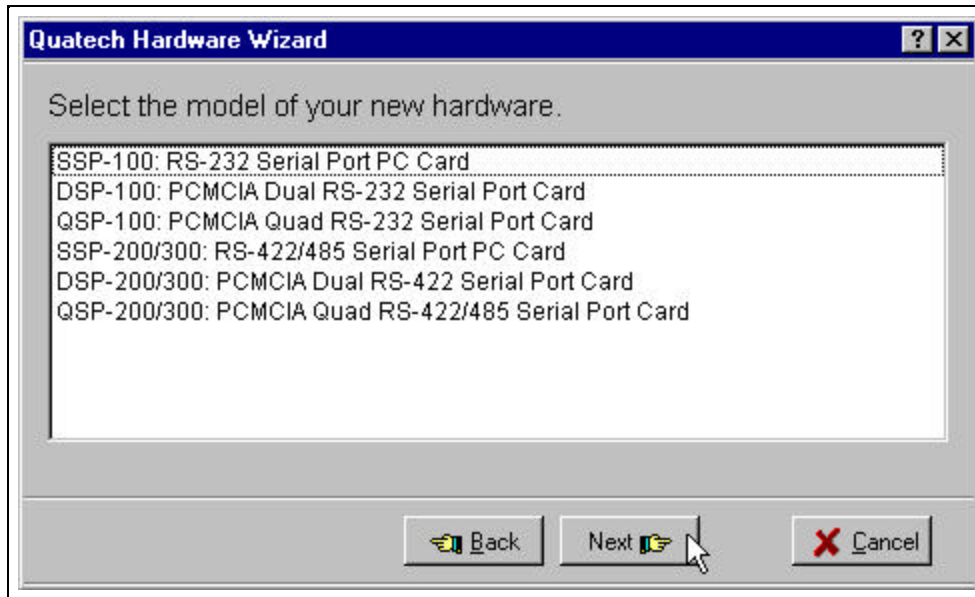

4. Complete the final steps of the installation, insert the PCMCIA Card and re-boot the computer.

Additional help is available online

The SSP-200/300 PC Card should now be configured. In the future, Windows NT will automatically recognize and configure the SSP-200/300.

Note: Windows NT does not support 'Plug and Play' for PCMCIA cards. The PCMCIA Card must be inserted prior to starting Windows NT and can not be removed and reinserted while Windows NT is running.

6. Hardware Information

6.1 Auxiliary Channel Configuration

An auxiliary channel is provided which allows for handshaking between the SSP-200/300 port and a peripheral device. This auxiliary channel may be configured in one of two ways:

- v RTS-CTS handshake enabled.
- v handshaking is disabled.

6.1.1 Auxiliary Channel: RTS-CTS Handshaking.

The RTS-CTS handshake may be enabled so that RTS (request to send) is the auxiliary output signal on AUX OUT+ (pin 1) and AUX OUT- (pin 6). Similarly, CTS (clear to send) is the auxiliary input signal on AUX IN+ (pin 5) and AUX IN- (pin 9). This configuration is shown below.

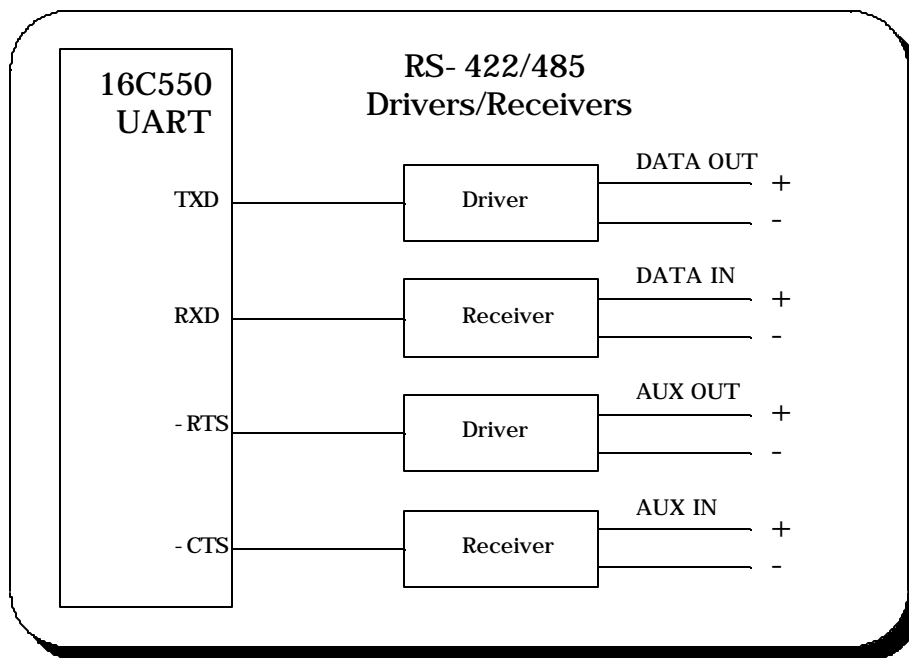

Figure 9. Auxiliary Channel RTS-CTS Handshaking

6.1.2 Auxiliary Channel: Handshaking Disabled.

The SSP-200/300 ports may be configured so that the RTS-CTS handshake is disabled. This is the default configuration. In this configuration, RTS and CTS from the 16C750 UART will be looped back to each other. In addition, the auxiliary output and input signals will be looped back to each other. This configuration is shown below:

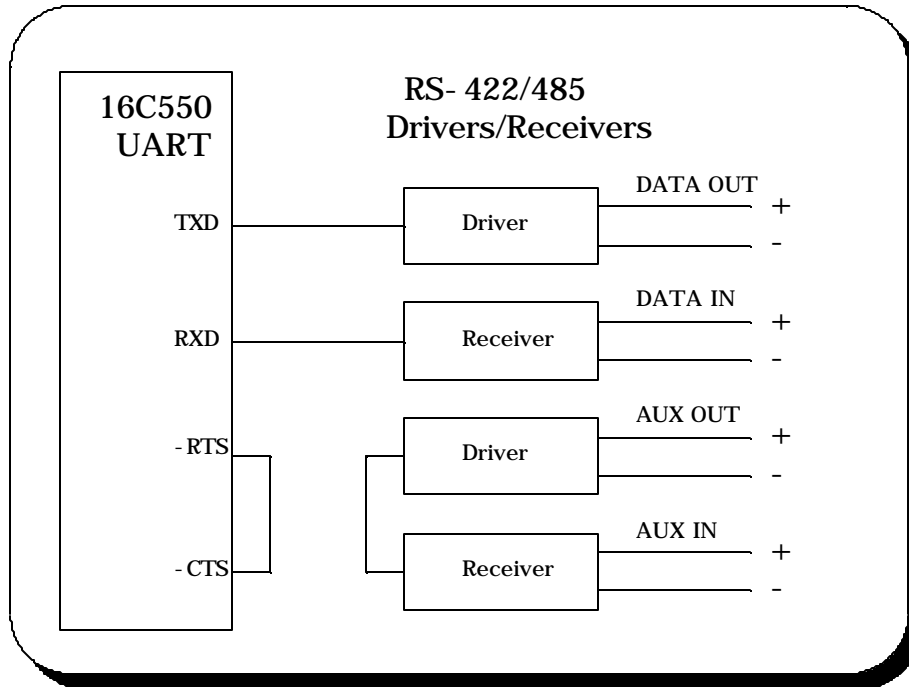

Figure 10. Auxiliary Channel Handshaking Disabled

6.2 Half Duplex Operation

The SSP-200/300's ports may be configured for either full duplex or half duplex operation. By default, the RS-422/485 ports are configured for full duplex operation with the RS-422/485 output drivers always enabled.

In half duplex mode, the RS-422/485 transmitter may be enabled and disabled via the RTS (request to send) or DTR (data terminal ready) signals. Both RTS and DTR are controlled through the Modem Control Register of the 16750.

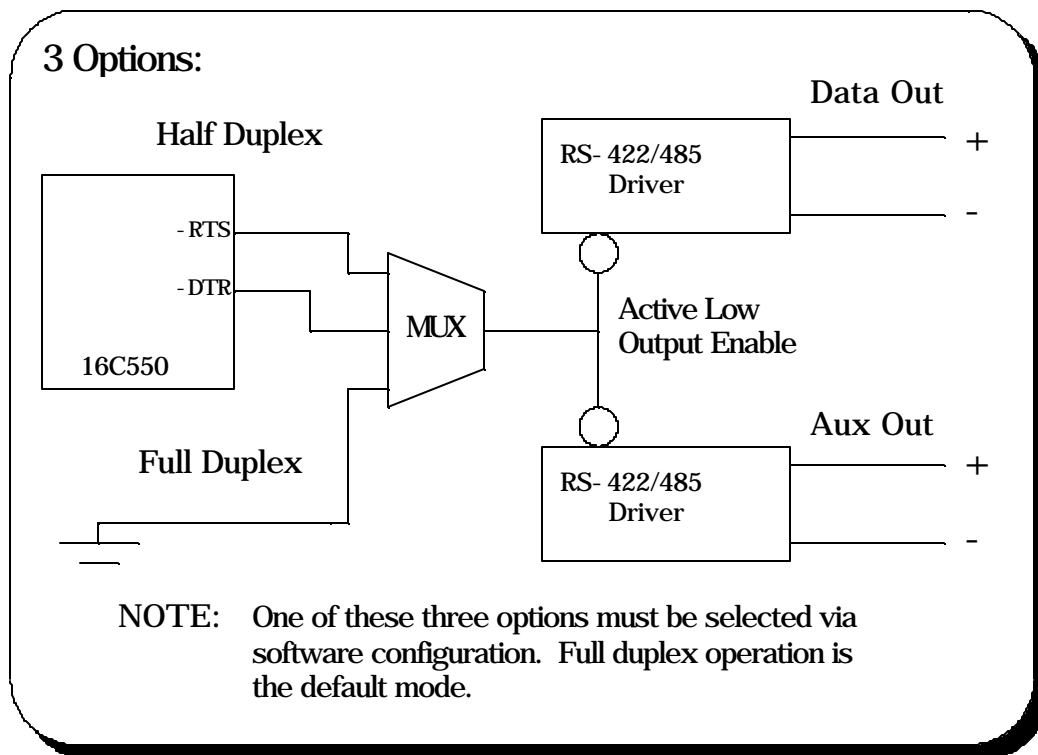

Figure 11. RS-422/485 Driver Enable Options

If RTS is selected as the signal to enable the output drivers, setting 'bit 1' of the Modem Control Register (to logic '1') will enable the output drivers and clearing 'bit 1' of the Modem Control Register (to logic '0') will force the outputs into a high impedance state.

Similarly, if DTR is chosen as the signal to enable the output drivers setting 'bit 0' of the Modem Control Register (to logic '1') will enable the output drivers and clearing 'bit 0' of the Modem Control Register (to logic '0') will force the outputs into a high impedance state.

Selection of half duplex mode operation is dependent upon the configuration software and/or the operating system used. Each of these, however, ultimately control the half duplex mode by accessing the PCMCIA Configuration Register on the SSP-200/300.

CAUTION:

When operating in half duplex mode, the transmitter output drivers **must** **be** disabled before receiving any information. Failure to do so will result in two output drivers being connected together which may cause damage to the adapter, the computer, and/or the peripheral equipment.

6.3 Termination Resistors

No termination resistors are provided on the SSP-200/300 ports. Both output and input signals are connected only to the external connector. Any termination which is required must be added externally.

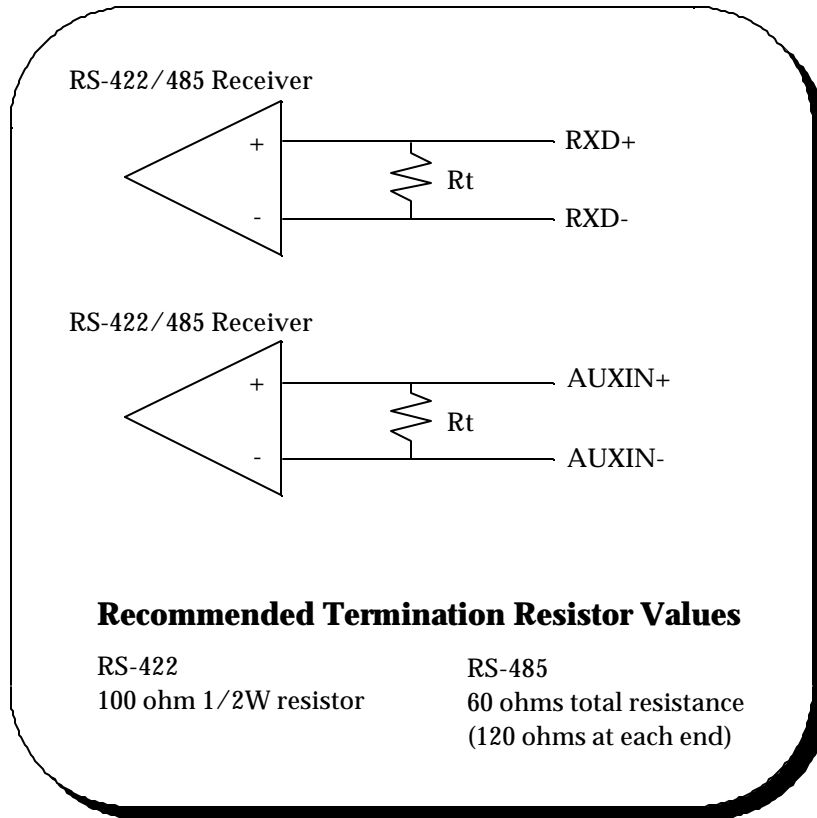

Figure 12. RS-422/485 Termination

6.4 PCMCIA Configuration Register

Some PCMCIA software utilities allow the PCMCIA Configuration Option Register to be examined. The PCMCIA Configuration Option Register of the SSP-200/300 is defined as follows:

BIT	DESCRIPTION	
4-7	Reserved	Reserved
2-3	OutputEn	00 = Outputs always enabled (default) 01 = DTR used as output enable 10 = RTS used as output enable
1	ModemCntrl	1 = RTS- CTS handshake 0 = RTS-CTS loopback
0	Reserved	Reserved

Figure 13. PCMCIA Configuration Options Register

7. External Connections

An adapter cable is included with the SSP-200/300 to convert the 9-pin PCMCIA output connector into a standard D-9 female connector, data terminal equipment (DTE), as shown in the figures below.

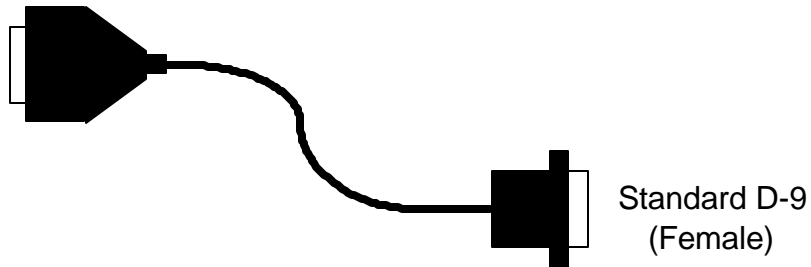

Figure 14. SSP-200/300 Adapter Cable.

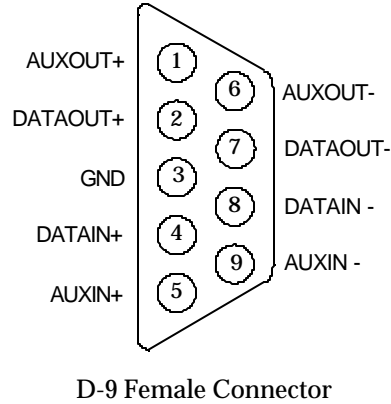

Figure 15. RS-422/485 Signal Assignment.

(This page intentionally left blank.)

8. Specifications

Bus Interface	PCMCIA PC Card Standard 2.1 compliant
Physical Dimensions	Type II PCMCIA card (5mm)
Maximum Baud Rate	120K
Power Requirements	+5 volts 8.85 mA (typical) 14.14 mA (maximum)
Connector	Adapter to standard female D-9

SSP-200/300
User's Manual
Revision 1.00
March 2002

P/N 940-0075-220