

Product Description

Model EIR505-xx

Documentation Number: EIR505-xx_0708m



707 Dayton Road -- P.O. Box 1040 -- Ottawa, IL 61350 USA

Phone (815) 433-5100 -- General Fax (815) 433-5105

Phone (815) 433-5100 -- **General Fax** (815) 433-5105

Website: www.bb-elec.com

Sales e-mail: orders@bb-elec.com -- **Fax** (815) 433-5109

Technical Support e-mail: support@bb.elec.com -- **Fax** (815) 433-5104

European Headquarters

B&B Electronics

Westlink Commercial Park -- Oranmore, Co. Galway, Ireland

Phone +353 91-792444 -- **Fax** +353 91-792445

Website: www.bb-europe.com

Sales e-mail: sales@bb-europe.com

Technical Support e-mail: support@bb-europe.com

© 2008 B&B Electronics Mfg. Co. Inc. - Revised February 2008

Five Port Managed Industrial Ethernet Switches

User Manual

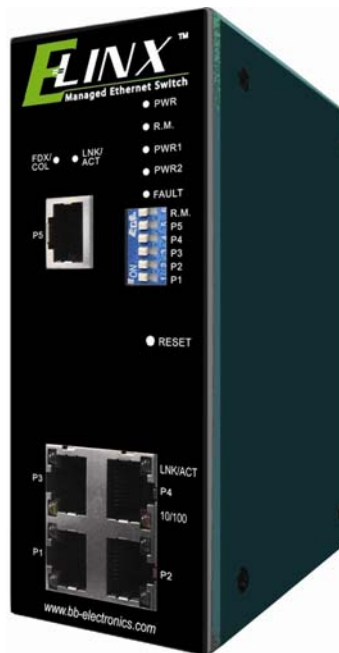

FCC

This Equipment has been tested and found to comply with the limits for a Class-A digital device, pursuant to Part 15 of the FCC rules. These limits are designed to provide reasonable protection against harmful interference. This equipment generates uses and can radiate radio frequency energy and, if not installed and used in accordance with the instructions, may cause harmful interference to radio communications. However, there is no guarantee that interference will not occur in a particular installation. If this equipment does cause harmful interference to radio or television reception, which can be determined by turning the equipment off and on, the user is encouraged to try to correct the interference by one or more of the following measures:

- Reorient or relocate the receiving antenna.
- Increase the separation between the equipment and receiver.
- Connect the equipment into an outlet on a circuit different from that to which the receiver is connected.
- Consult the dealer or an experienced radio/TV technician for help.

CE

This is a Class-A product. In a domestic environment this product may cause radio interference in which case the user may be required to take adequate measures.

Content

Features	7
Package Contents	8
Hardware Description.....	9
Physical Dimension (W x H x D)	9
Front Panel.....	9
Reset Button.....	9
Bottom View	10
DIP-switch	11
LED Indicators.....	12
Ports.....	13
Cabling	15
Wiring the Power Inputs	15
Wiring the Fault Alarm Contact	16
Mounting Installation.....	17
DIN-Rail Mounting	17
Panel Mounting	19
Hardware Installation.....	20
Network Application	21
X-Ring Application.....	21

Coupling Ring Application	22
Dual Homing Application	23
Web-Based Management	24
About Web-based Management	24
Preparing for Web Management	24
System Login.....	25
Port status	26
Single Port Information	27
Port Statistics	27
Port Control	28
Switch Settings.....	29
Port Mirroring.....	30
VLAN configuration	31
Port-based VLAN	32
802.1Q VLAN	34
IP Address.....	37
SNTP Configuration	38
IP Security	41
RSTP Configuration	42

System Configuration	42
Per Port Configuration	44
X-Ring	45
QoS Configuration	47
IGMP	49
Security Manager	50
Configuration Backup	51
TFTP Restore Configuration	51
TFTP Backup Configuration	51
TFTP Update Firmware	52
Factory Default	53
System Reboot	53
Save Configuration	54
Rate Control	54
Trouble shooting	56
Technical Specification	57

Introduction

The Elinx EIR505 series of Industrial Managed Ethernet Switches provide powerful functionality in a small package. Designed for industrial applications, these switches are highly reliable.

Features

- Conforms to IEEE 802.3 10Base-T, 802.3u 100Base-TX/100Base-FX
- 5-port 10/100TX industrial switch (Fiber Optic models have 1 100FX port)
- RJ-45 ports support auto MDI/MDI-X
- Store-and-Forward switching architecture
- Wide-range redundant input power connections
- DIN rail and panel mount design
- Easy to configure
- Web based management
- IEEE 802.1p class of service and port based, Tag based, and Type of service priority method
- Each port supports 4 priority queues
- Port based VLAN / 802.1 Q Tag VLAN
- IGMP with Query mode for multi media application
- DHCP client
- Ingress packet filter and egress rate limit.
- Relay alarm output for system events
- Input power reverse polarity protection
- Port mirror for TX only, TX and RX packet
- IEEE 802.3x flow control
 - Flow control with full-duplex
 - Back pressure with half-duplex
- X-Ring function
- SNTP
- TFTP firmware update, system configuration restore and backup
- 1Mbits Embedded memory
- 2K MAC address table

Package Contents

- 5 Port Managed Industrial Switch
- One DIN-Rail Mount (attached to the switch)
- One Panel mount plate and six screws
- One Quick Start Guide
- One CD ROM containing a users manual

If any item is missing or damaged, contact B&B Electronics.

Hardware Description

Physical Dimension (W x H x D)

2.3 x 5.7 x 4.3 in (5.8 x 14.5 x 10.9 cm)

Front Panel

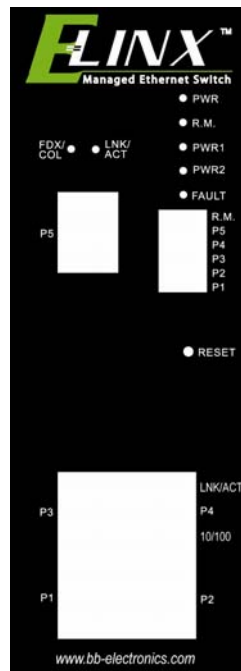

EIR505 Front Panel

Reset Button

The reset button is used to restart the reboot the switch or restore it to the factory default configuration.

- **Restart:** Press the button for 2 seconds and release.
- **Set to factory default value:** Press the button for 5 seconds and release.

DIP-switch

The six position DIP-switch is used to configure the relay alarm ring master mode. The default value for each position is **OFF**. Software configuration is also required for the alarm relay. The alarm relay contacts are normally open.

DIP Switch No	Status	Description
1	OFF	Disable port 1 Alarm
	ON	Enable port 1 Alarm.
2	OFF	Disable port 2 Alarm
	ON	Enable port 2 Alarm.
3	OFF	Disable port 3 Alarm
	ON	Enable port 3 Alarm.
4	OFF	Disable port 4 Alarm
	ON	Enable port 4 Alarm.
5	OFF	Disable port 5 Alarm
	ON	Enable port 5 Alarm.
6	OFF	Disable the master ring function.
	ON	Enable the switch as the ring master in the X-Ring group.

LED Indicators

There are 7 diagnostic LEDs located on the front panel. They provide real-time status information.

LED	Status	Meaning
Power	Green	The switch is on
	Off	The switch is off or no power input is available
R.M. (Ring Master)	Green	The switch is the master of X-Ring group
	Off	The industrial switch is not the master of an X-Ring group
Power 1	Green	Power source 1 is available
	Off	Power source 1 is not available
Power 2	Green	Power source 2 is available
	Off	Power source 2 is not available
Fault	Yellow	Power failure or port failure (See Alarm setting for details).
	Off	Normal Operation
LNK/ACT (port 5) RJ-45 or Fiber Optic	Green	The port is linked
	Blinking	The port is transmitting or receiving
	Off	No device attached
FDX/COL (port 5) RJ-45 or Fiber Optic	Yellow	The port is operating in full-duplex mode
	Blinking	Data Packet Collision
	Off	The port in half-duplex mode or is not connected to a device

Ports

■ RJ-45 ports

There are 5x 10/100Mbps auto-sensing ports for 10Base-T or 100Base-TX device connection. The ports are auto-sensing and auto MDI/MDIX.

RJ-45 Pin Assignments

Pin Number	Assignment
1	Tx+
2	Tx-
3	Rx+
6	Rx-

All ports on this switch support automatic MDI/MDI-X operation. Straight-through cables can be used for all network connections. In straight-through cable, pins 1, 2, 3, and 6, at one end of the cable, are connected straight through to pins 1, 2, 3 and 6 at the other end of the cable. The table below shows the 10BASE-T/100BASE-TX MDI and MDI-X port pin outs.

Pin MDI-X	Signal Name	MDI Signal Name
1	Receive Data plus (RD+)	Transmit Data plus (TD+)
2	Receive Data minus (RD-)	Transmit Data minus (TD-)
3	Transmit Data plus (TD+)	Receive Data plus (RD+)
6	Transmit Data minus (TD-)	Receive Data minus (RD-)

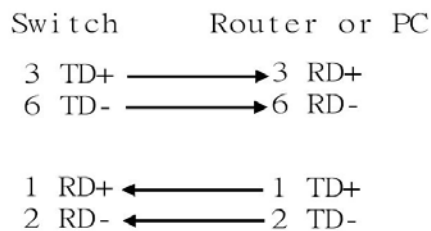

Straight Through Cable Schematic

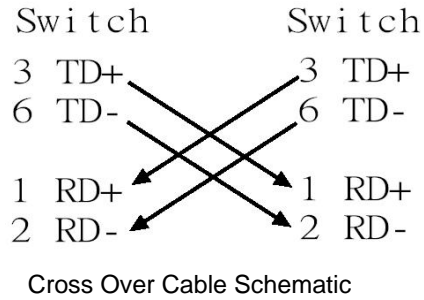

■ **Fiber Port**

There is one 100Base-FX port. The fiber port is SC type connector in multi mode (2Km) or single mode (30Km).

Connect the fiber port as described below.

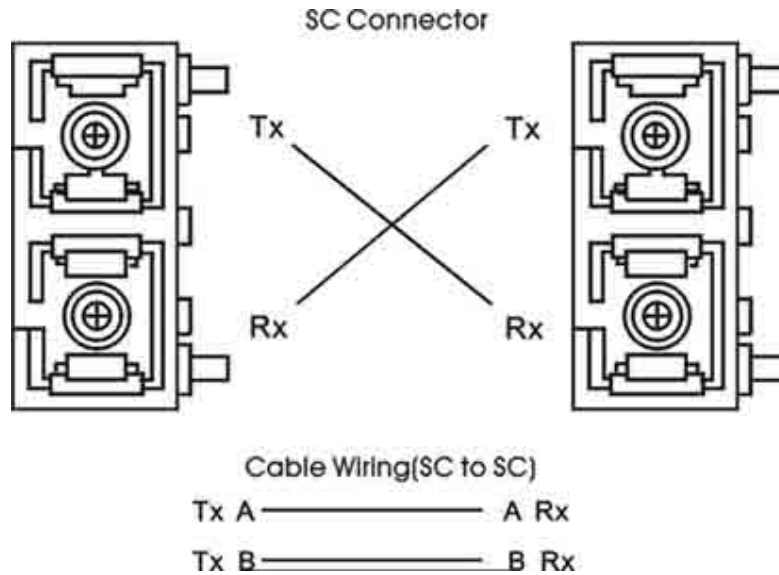

ATTENTION



This is a Class 1 Laser/LED product. Do not stare into the Laser/LED Beam.

Cabling

- Use Category 5 cabling for RJ-45 port connections. The cable must be less than 328 ft (100 meters) long.
- Use 8/125 or 9/125 um for single-mode fiber. Distances up to **30 Kilometers** are supported.
- Fuse 50 or 62.5/125 um for multi-mode fiber cable. Distances up to **2Kmare** supported.

Wiring the Power Inputs

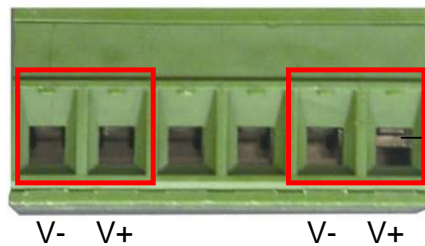

1. Insert the positive and negative wires into the V+ and V- connector on the terminal block connector

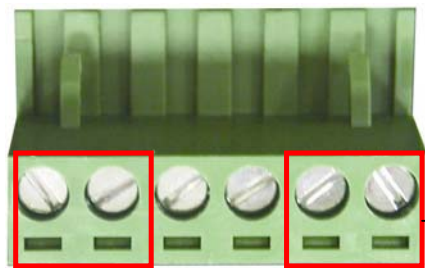

2. Tighten the wire-clamp screws

[NOTE] Use 12~ 24 AWG wire.

Wiring the Fault Alarm Contact

The fault alarm contacts are located in the middle of terminal block. Insert the wires and set the Dipswitch to “ON”. When a power source fails or a link fault occurs, the contacts will close.

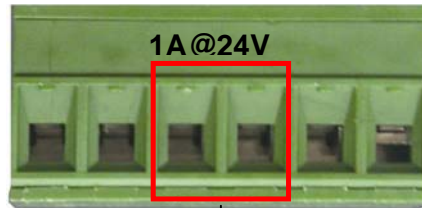

Insert the wires into the fault alarm contact

[NOTE] The wire range of terminal block is from 12~ +24 AWG.

[NOTE] Relay contacts are normally open.

[NOTE] The relay alarm also requires software configuration. Refer to the web based management Alert section.

Mounting Installation

DIN-Rail Mounting

Rear Panel of
the switch

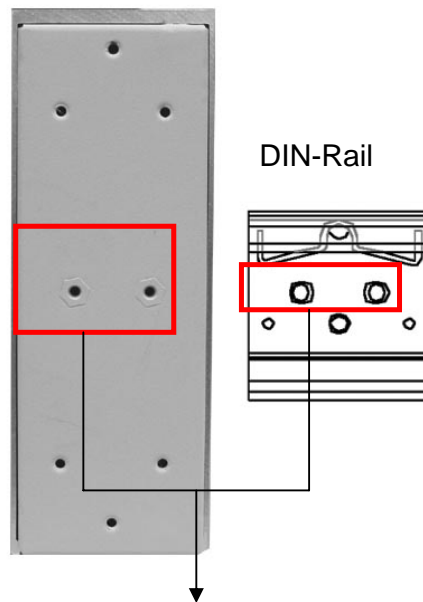

DIN-Rail

- Use the screws to attach the DIN-Rail to the industrial switch
- To remove the DIN-Rail, reverse the step 1.

1. First, insert the top of DIN-Rail into the track.

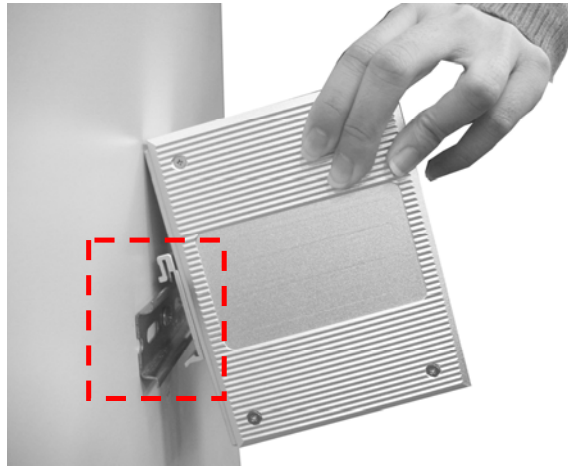

2. Then, lightly push the DIN-Rail into the track.

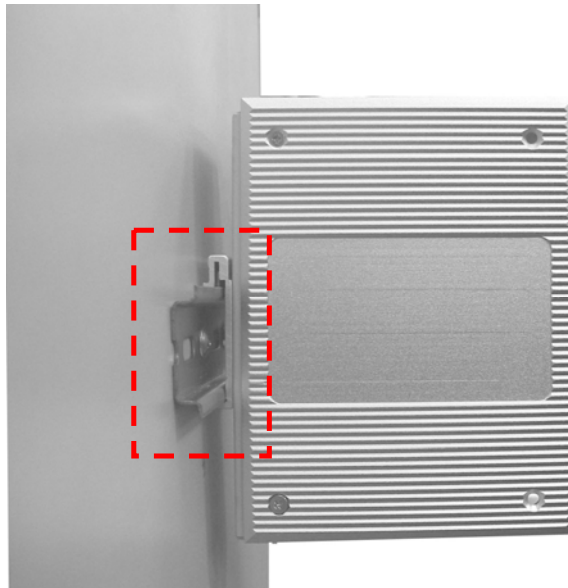

3. Ensure the DIN-Rail is tightly secured to the track.
4. To remove the industrial switch from the track, reverse steps above.

Panel Mounting

Follow the steps below to mount the industrial switch with the Panel mount plate.

1. Remove the DIN-Rail from the industrial switch.
2. Place the wall Panel plate on the rear of the industrial switch.
3. Use the screws to attach the Panel plate to the industrial switch
4. Use the hook holes at the corners of the panel mount plate to attach the industrial switch to the panel.
5. To remove the panel mount plate, reverse steps above

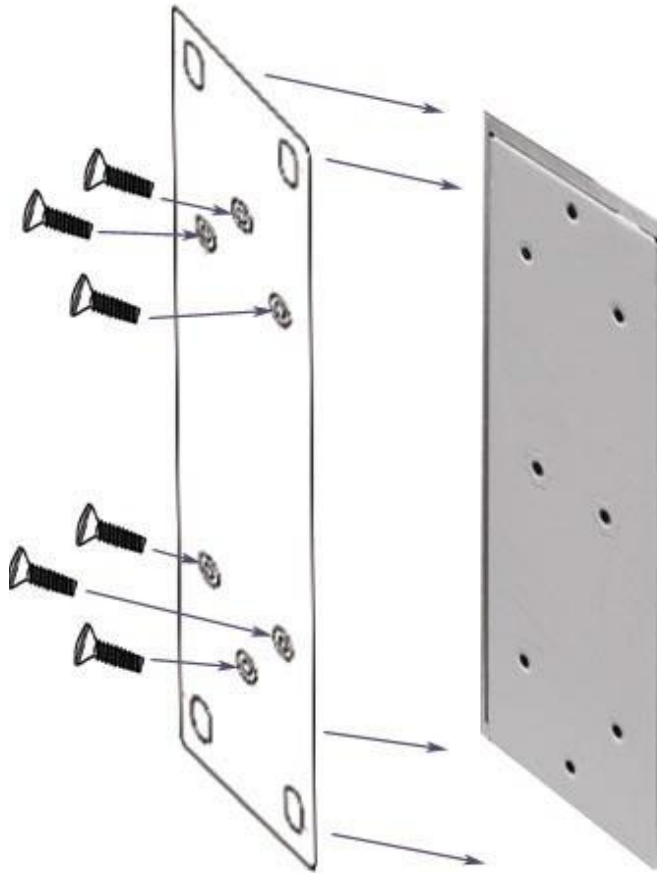

Hardware Installation

1. Unpack the Industrial switch.
2. Ensure the DIN-Rail is tightly screwed to the Industrial switch. If not, refer to **DIN-Rail Mounting** section for DIN-Rail installation. To panel mount the Industrial switch, refer to **Panel Mounting** section.
3. Apply power to the switch (refer to the **Wiring the Power Inputs** section). The power LED will light.
4. Connect CAT 5 cables to the Industrial switch's RJ-45 ports and to the network devices.

[NOTE] If the network devices do not support MID/MDIX, a crossover cable may be required.

5. Connect the fiber optic cables to the industrial switch and network device. Ensure that the switch's fiber optic transmitter is connected to the network devices receiver and vice versa.
6. When all the connections are made and the LEDs show normal indications, the installation is complete.

Network Application

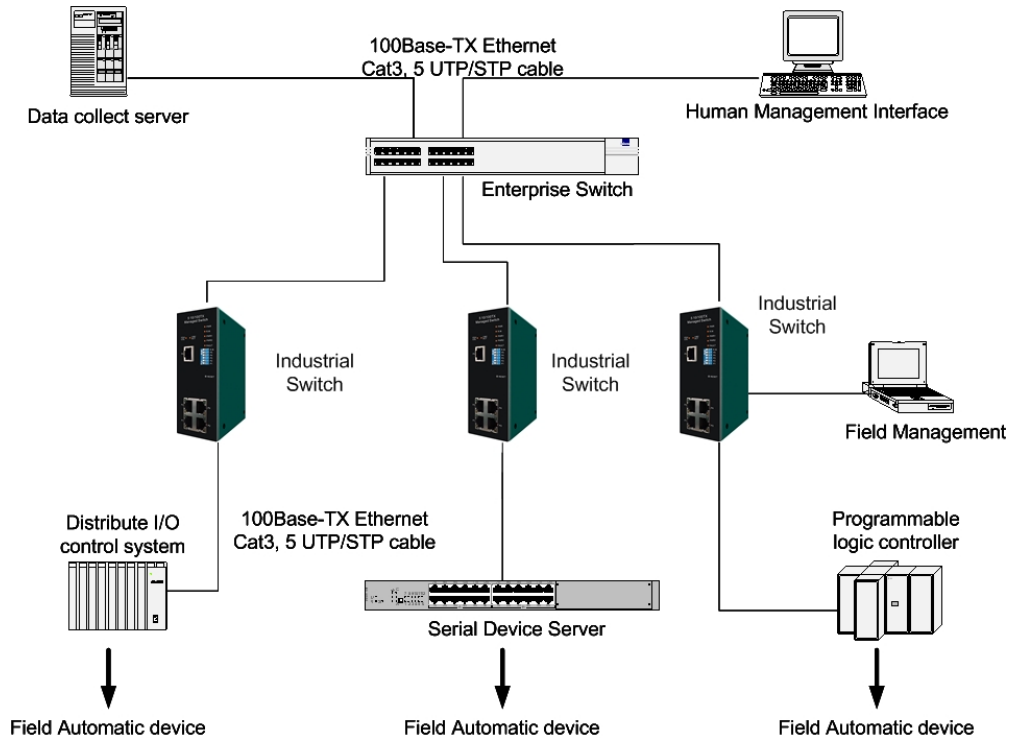

X-Ring Application

The EIR505 series of Industrial Switches incorporate the X-Ring Protocol to ensure network reliability and system restoration within 300 ms in the event of a connection failure. The X-Ring algorithm is similar to the spanning tree protocol (STP) algorithm but it has faster recovery time. The following figure below is an example of an X-Ring application.

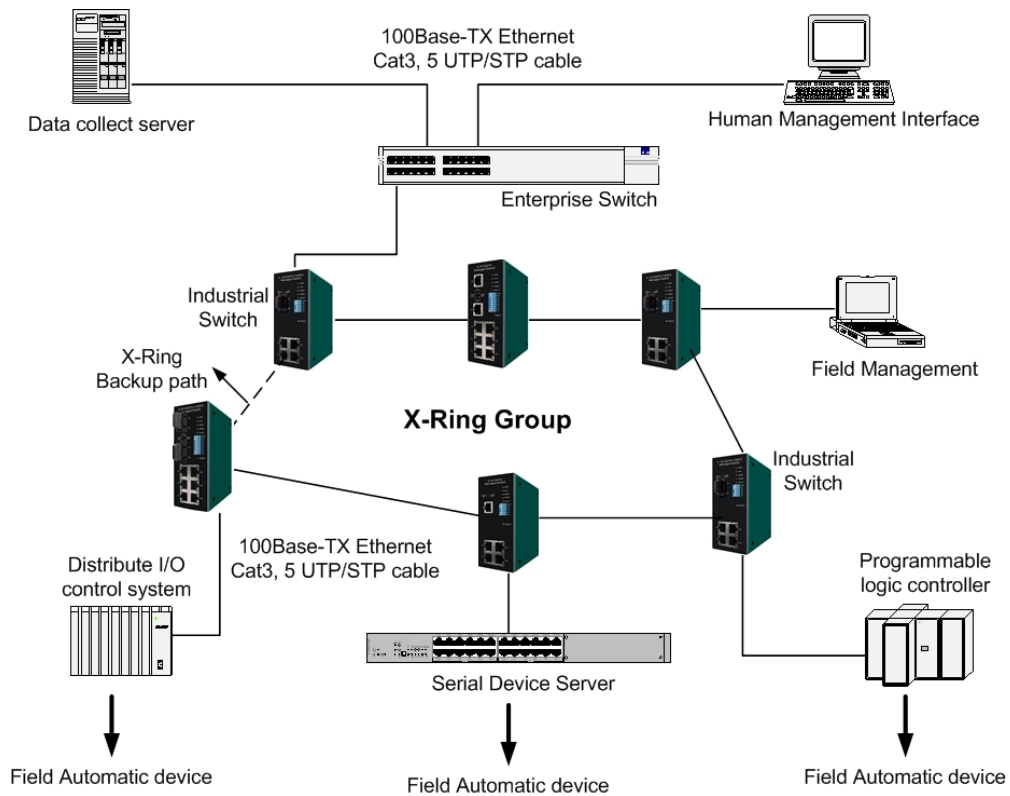

Coupling Ring Application

If the network has more than one X-Ring group, the coupling ring function is used to connect them and add redundancy. This ensures that transmissions between the two ring groups will not fail. The figure below is an example of the coupling ring application.

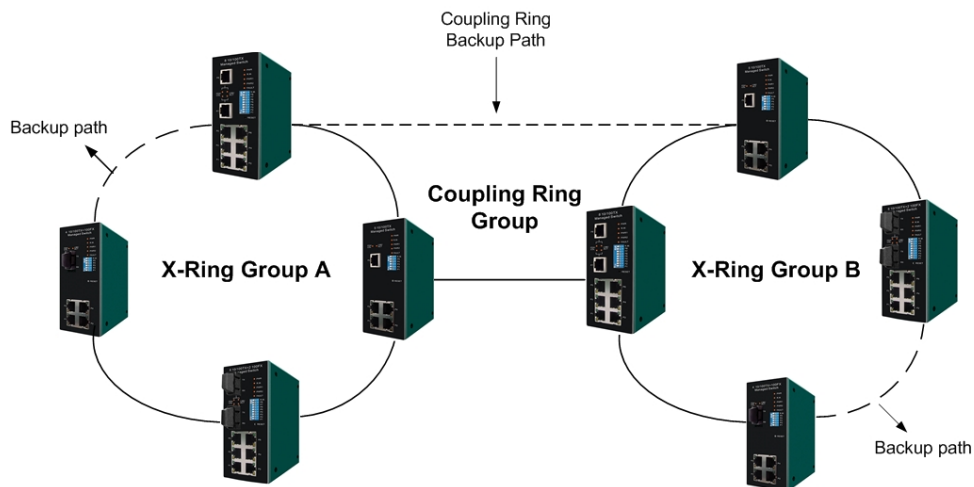

Dual Homing Application

The Dual Homing function is used to prevent a connection loss between the X-Ring group and the upper level/core switch. Assign a port in each X-ring group to be the Dual Homing ports. The Dual Homing function can only be used when the X-Ring function is active. Each X-Ring group can have one Dual Homing port.

[NOTE] In the Dual Homing architecture, the upper level switches must have Rapid Spanning Tree Protocol enabled.

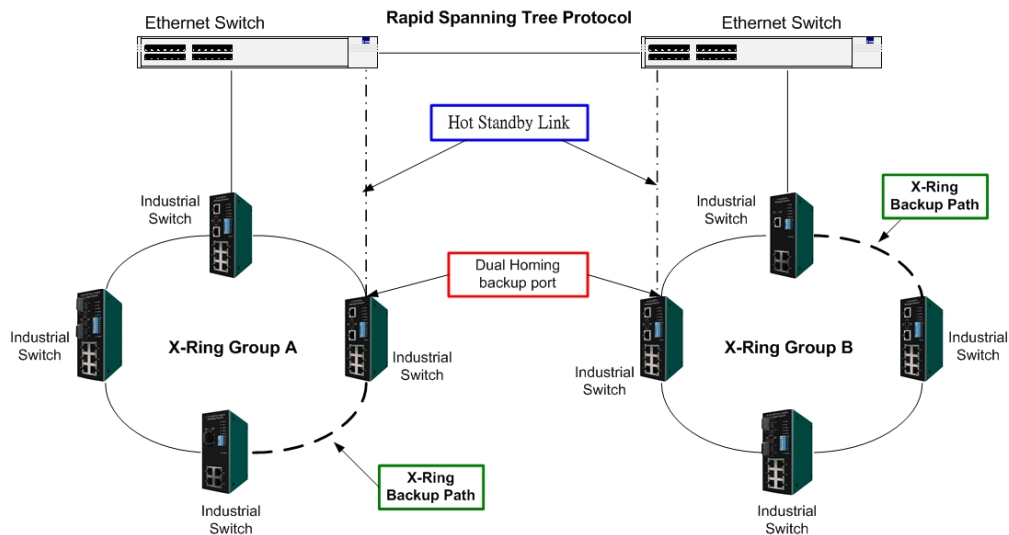

Web-Based Management

About Web-based Management

The switch has an embedded HTML web site residing in flash memory. This site offers advanced management features and allows the switch to be configured from anywhere on the network.

The web site is designed for Internet Explorer 5.0 and uses Java Applets to reduce bandwidth consumption, enhance access speed, and present an intuitive user interface.

[NOTE] By default, IE5.0 and later versions do not allow Java Applets to activate sockets. The user must modify the browser setting to enable Java Applets to operate network ports.

Preparing for Web Management

Before using web management, install the industrial switch on the network and verify that a PC on the local network can connect with the switch through the web browser. The default IP Address, Subnet Mask, Username and Password is listed below:

- IP Address: **192.168.16.1**
- Subnet Mask: **255.255.255.0**
- Default Gateway: **192.168.16.254**
- User Name: **root**
- Password: **root**

System Login

1. Launch Internet Explorer on the PC.
2. Enter "http:// "+" the IP address of the switch", in the address window and then Press "**Enter**".
3. The login screen will appear.
4. Enter the user name and password.
5. Press "**Enter**" or "**OK**", the home screen will appear.

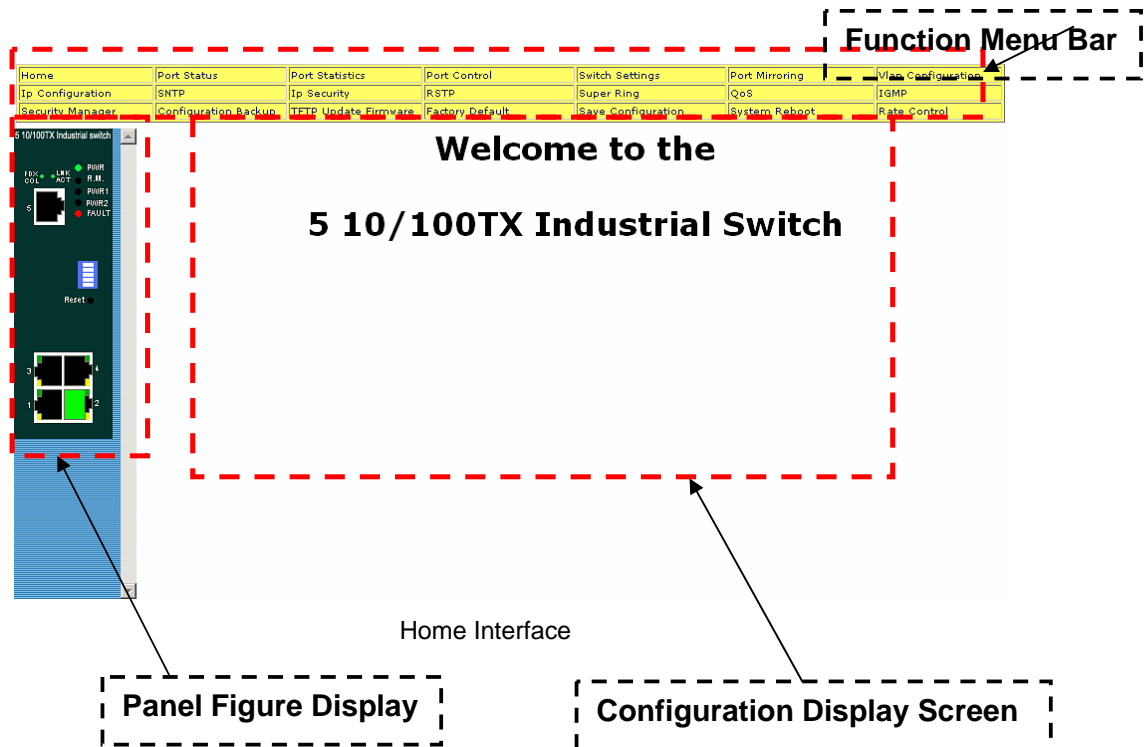

Port status

Shows the status of each port

- **Port:** Displays the port number
- **Type:** Displays the speed and mode, ex: 100TX = 100Mbps
- **Link:** Displays the ports status (up or down)
- **State:** Displays the ports status (disabled or enabled). Unlinked is displayed as “off ”
- **Negotiation:** Displays the auto negotiation mode (auto or forced).
- **Speed Duplex:** Displays the port connection speed. “Config” is the configured value. “Actual” is the current value.
- **Flow Control:** Displays the flow control status as “Symmetric” or “Asymmetric” in full mode. “Disable” means that flow control is not enabled “Config” indicates that the value is user configured. “Actual” is the current value of the port.

Port Status

Port	Type	Link	State	Negotiation	Speed Duplex		Flow Control	
					Config	Actual	Config	Actual
Port.01	100TX	Down	Enable	Auto	100 Full	N/A	Symmetric	N/A
Port.02	100TX	Up	Enable	Auto	100 Full	100 Full	Symmetric	ON
Port.03	100TX	Down	Enable	Auto	100 Full	N/A	Symmetric	N/A
Port.04	100TX	Down	Enable	Auto	100 Full	N/A	Symmetric	N/A
Port.05	100TX	Down	Enable	Auto	100 Full	N/A	Symmetric	N/A

Port Status interface

Single Port Information

Click the desired port on the Panel figure. The single port information window will display the current port information.

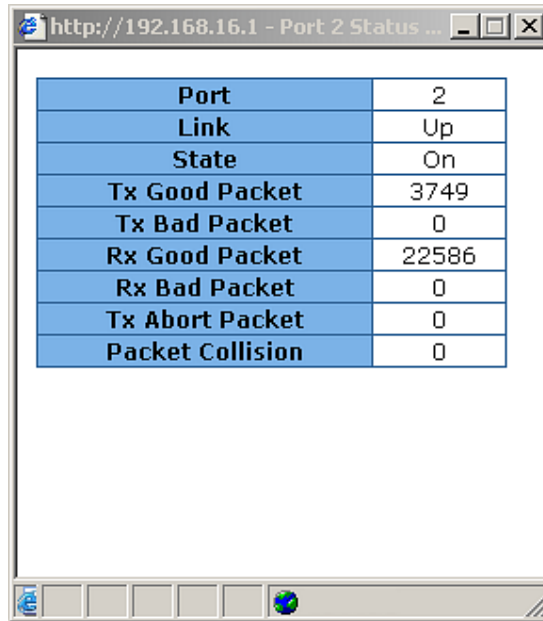

The screenshot shows a web browser window with the address bar containing 'http://192.168.16.1 - Port 2 Status ...'. The main content area displays a table with the following data:

Port	2
Link	Up
State	On
Tx Good Packet	3749
Tx Bad Packet	0
Rx Good Packet	22586
Rx Bad Packet	0
Tx Abort Packet	0
Packet Collision	0

Port information interface

Port Statistics

Displays port statistics. Click button to reset.

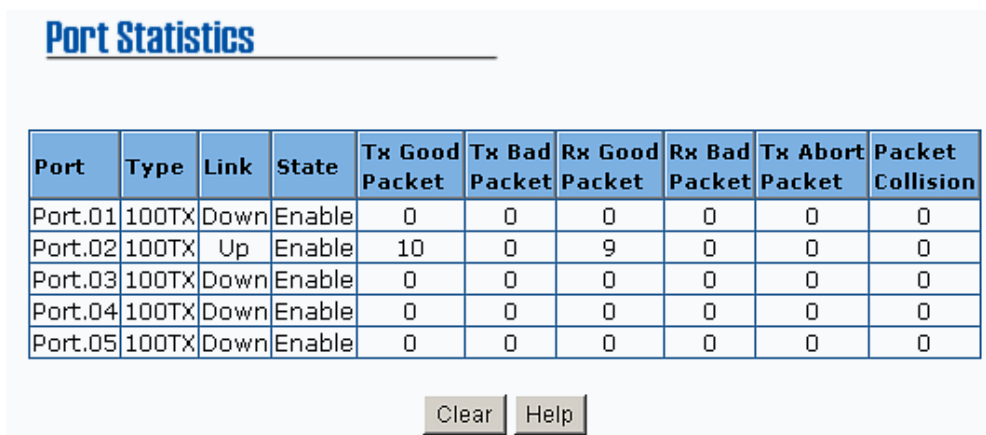

The screenshot shows a web page titled 'Port Statistics'. Below the title is a table with the following data:

Port	Type	Link	State	Tx Good Packet	Tx Bad Packet	Rx Good Packet	Rx Bad Packet	Tx Abort Packet	Packet Collision
Port.01	100TX	Down	Enable	0	0	0	0	0	0
Port.02	100TX	Up	Enable	10	0	9	0	0	0
Port.03	100TX	Down	Enable	0	0	0	0	0	0
Port.04	100TX	Down	Enable	0	0	0	0	0	0
Port.05	100TX	Down	Enable	0	0	0	0	0	0

Below the table are two buttons: and .

Port Statistics Interface

Port Control

Used to set up the port.

1. Select the port by scrolling down the **Port** column. The current port information will be displayed in the table below.
2. **State:** Enables or disables the port.
3. **Negotiation:** Sets the negotiation mode to Auto, Nway (specify the speed/duplex of the port and enable auto-negotiation), or Forced.
4. **Speed:** Sets the transmit speed of the port
5. **Duplex:** Sets the port to full-duplex or half-duplex
6. **Flow control:** Sets flow control function to **Symmetric** or **Asymmetric** in Full Duplex mode(The default value is **Disable**)
7. Click the button to apply configurations
8. Select the port again to verify the configuration.

[NOTE] If the configuration is not saved it will be lost when the switch is powered off.

Port Controls

Port	State	Negotiation	Speed	Duplex	Flow Control
Port.01					
Port.02					
Port.03	Enable	Auto	100	Full	Symmetric
Port.04					
Port.05					

Port	Type	Link	State	Negotiation	Speed Duplex		Flow Control	
					Config	Actual	Config	Actual
Port.01	100TX	Down	Enable	Auto	100 Full	N/A	Symmetric	N/A

Port Control interface

Switch Settings

Used to assign the system name, location and to view system information

- **System Name:** Assigns a name to the switch. The maximum length is 64 bytes
- **System Location:** Assigns a physical location for the switch. The maximum length is 64 bytes
- **System Description:** Displays the description of switch. This is read only and cannot be modified
- **Firmware Version:** Displays the firmware version
- **Kernel Version:** Displays the kernel software version
- **Hardware version:** Display the hardware version
- **MAC Address:** Display the unique hardware address assigned by manufacturer (this value is different for each switch)

Port Mirroring

Port mirroring is a method to monitor traffic in switched networks. This is accomplished by mirroring the traffic going in and out of the monitored ports to a specifically designated port (the mirror port).

1. **Port Mirroring Mode:** Sets the mirror mode. Select disable to disable port mirroring. Select TX to monitor data being transmitted by a port. Select both to monitor port data being transmitted and received by a port. The default value is “Disable”.
2. **Analysis Port:** This is the port used to see all monitored port traffic (This port can be connected to a LAN analyzer or Netxray).
3. **Monitor Port:** Check the box to monitor the port. Up to 4 ports can be designated as monitor ports.

[NOTE]

If the configuration is not saved, it will be lost when the port is powered off.

Port Mirroring Mode :	Disable
Analysis Port :	None
Monitor Port	State
Port.01	<input type="checkbox"/>
Port.02	<input type="checkbox"/>
Port.03	<input type="checkbox"/>
Port.04	<input type="checkbox"/>
Port.05	<input type="checkbox"/>

Apply Help

Port Mirroring interface

VLAN configuration

A Virtual LAN (VLAN) can be thought of as a broadcast domain that exists within a switch or a defined set of switches. By grouping switch ports into VLANs, traffic flooding is limited since devices can only communicate directly with devices belonging to the VLAN. Creating a VLAN from a switch is the logical equivalent of reconnecting a group of devices to another Layer 2 switch. However, the network devices retain their same physical connection. The EIR505 series switches support port-based and 802.1Q (tagged-based) VLAN. In the default configuration, the VLAN option is disabled.

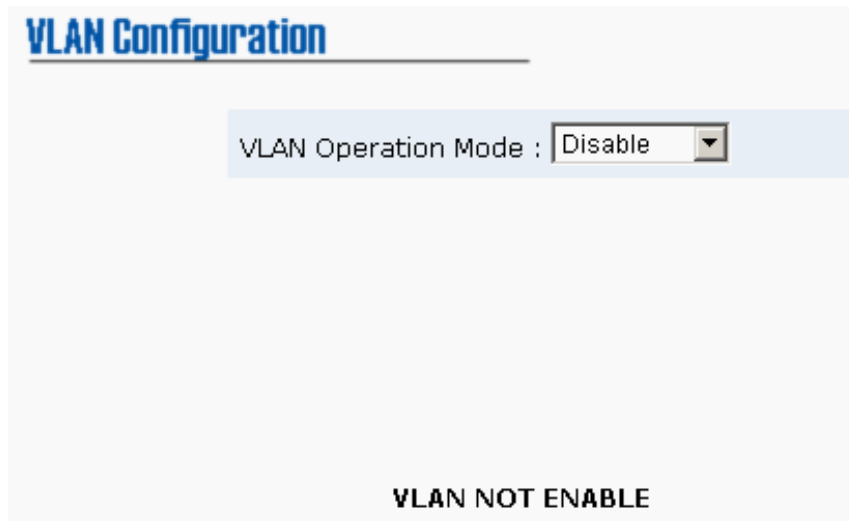

VLAN Configuration interface

Port-based VLAN

With port-based VLAN, the port is assigned to a VLAN. Therefore all devices attached to a given port should be members of the same VLAN. As with other VLAN configurations, the packets forwarded using this method do not leak into other VLAN domains on the network. After the port has been assigned to a VLAN, devices on the port cannot send to or receive from devices in other VLANs without the intervention of another layer 3 device or the ability to tag the data packet with a specific PVID.

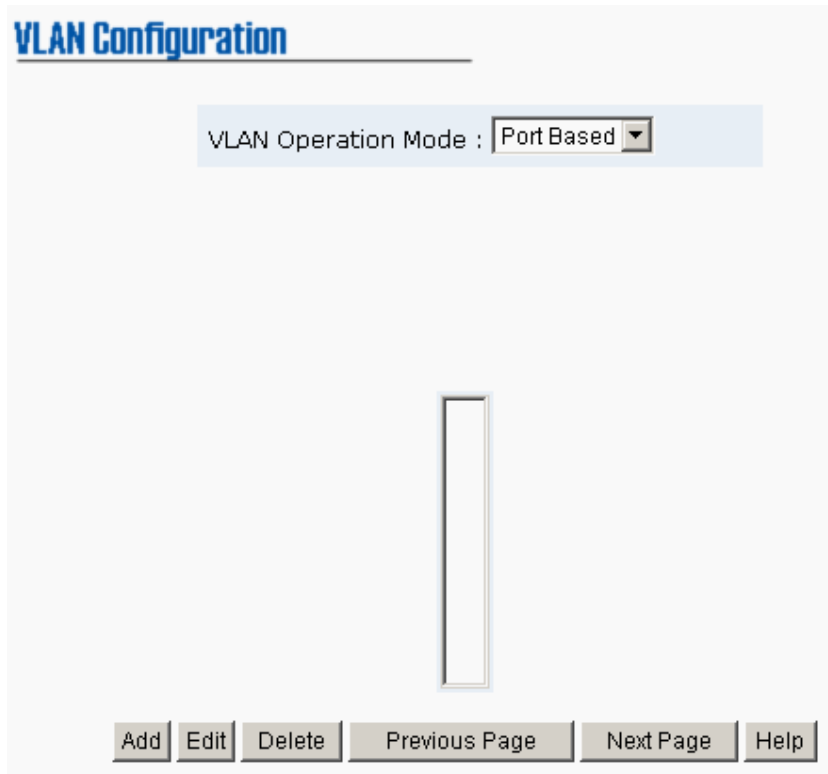

VLAN – Port Base interface

1. Click **Add** to add a new VLAN group. The EIR505 series supports up to 64 VLAN groups
2. Enter Group name, VLAN ID and select the members of VLAN group
3. Click **Apply**

VLAN Configuration

VLAN Operation Mode :

Group Name

VLAN ID

Port.01
Port.02
Port.03
Port.04
Port.05

VLAN—Port Base Add interface

4. The VLAN group will be displayed after apply is clicked
5. Click to view the next VLAN group
6. Use button to delete unwanted VLANs
7. Use button to modify existing VLANs

[NOTE] If the configuration is not saved, it will be lost when the switch is powered off

802.1Q VLAN

Tagged-based VLAN is an IEEE 802.1Q specification which allows VLANs to be created across devices from different vendors. IEEE 802.1Q VLAN uses a technique to insert a “tag” into the Ethernet frame. The tag contains a VLAN Identifier (VID).

When the 802.1Q VLAN is enabled, all ports on the switch belong to a default VLAN (VID 1). The default VLAN can't be deleted. The EIR505 series will support up to 64 VLAN groups.

VLAN Configuration

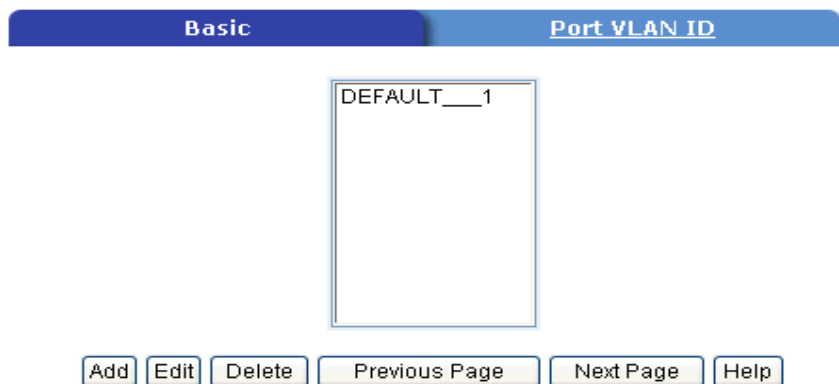
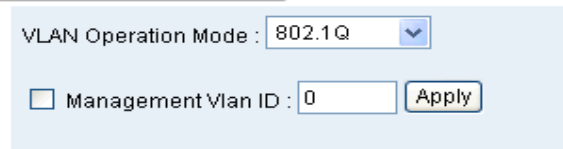

Basic	Port VLAN ID
DEFAULT__1	

802.1q VLAN interface

■ Basic

1. Click
2. **Management VLAN ID:** Used for Remote Management Security. When this option is selected, remote management is only available to the members of the indicated VLAN Group. Enter the specific VLAN ID number in Management VLAN ID column, check the box, and click the button. Example: If the management VLAN ID is 101 and the

VLAN group ID 101 includes ports 1, 2, and 4, only ports 1, 2, and 4 can perform remote management functions on the switch. If a port is in multiple VLAN groups, it can still perform management functions as long as one VLAN group ID is equal to the Management VLAN ID.

3. **Group Name:** assign a name for the new VLAN
4. **VLAN ID:** fill in a VLAN ID. The default is 1
5. From the Available ports box, select ports to add to the VLAN group and click **Add** button

VLAN Configuration

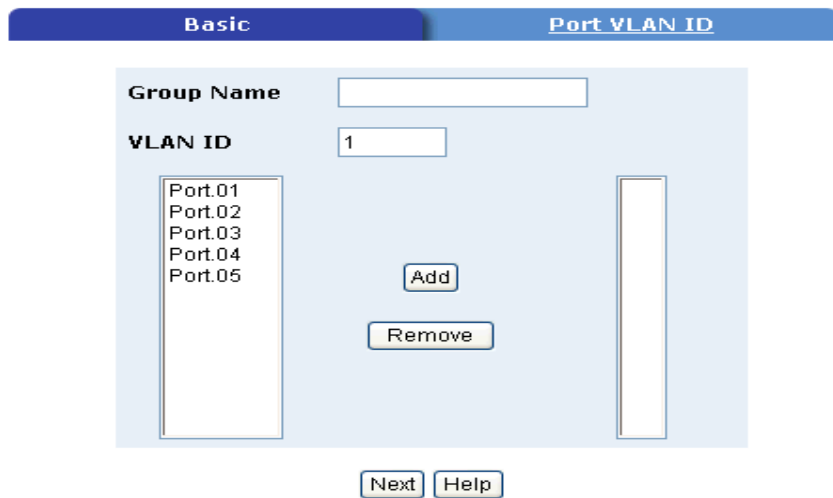
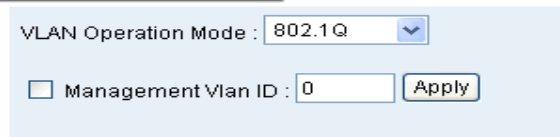

802.1q VLAN –Add interface

6. Click **Next** to bring up the configuration interface:

VLAN Configuration

VLAN Operation Mode : 802.1Q ▾

Management Vlan ID : 0

VLAN Name	VLAN002	
VLAN ID	2	
UnTag Member		
Port.01	Untag ▾	Port.02 Untag ▾
Port.03	Untag ▾	

7. Select outgoing frames as VLAN-Tagged frames or untagged and then click

■ Port VID: Configure port VID settings

1. **Port VLAN ID:** enter the port VLAN ID
2. And then, click
3. To reset to the default values, click button

VLAN Configuration

VLAN Operation Mode : 802.1Q

Management Vlan ID : 0

Basic Port VLAN ID

Port	Port VLAN ID
Port.01	
Port.02	
Port.03	
Port.04	

Port	VLAN ID
Port.01	1

802.1q VLAN – Port VLAN ID interface

[NOTE] If the configuration is not saved, it will be lost if the switch is powered off.

IP Address

Configure the IP Settings and DHCP client function

- **DHCP Client:** Use to enable or disable the DHCP client function. When the DHCP client function is enabled, the industrial switch will be assigned an IP address from the network DHCP server. After the “Apply” button is clicked, dialog box will indicate that the user that when the DHCP client is enabled, the current IP will lost and the new IP must be looked up on the DHCP server. The switch’s MAC Address will be required to look up the new IP Address on the DHCP Server. To cancel the DHCP client function, click “cancel”.
- **IP Address:** Assign a static IP address. This is not required if DHCP Client is enabled. The default IP is 192.168.10.1.

- **Subnet Mask:** Assign the subnet mask of the IP address. This is not required if the DHCP Client is enabled.
- **Gateway:** Assign the network gateway. The default gateway is 192.168.10.254.
- Click

IP configuration interface

SNTP Configuration

SNTP (Simple Network Time Protocol) allows the switch to synchronize its time with an SNTP Server.

1. **SNTP Client:** Enable or Disable SNTP
2. **Daylight Saving Time:** Enables or disables daylight saving time. When enabled, the daylight saving time period must be entered.
3. **UTC Time zone:** Used to calculate local time. Set the switch location time zone.

Local Time Zone	Conversion from UTC	Time at 12:00 UTC
November Time Zone	- 1 hour	11am
Oscar Time Zone	-2 hours	10 am
ADT - Atlantic	-3 hours	9 am

Daylight		
AST - Atlantic Standard EDT - Eastern Daylight	-4 hours	8 am
EST - Eastern Standard CDT - Central Daylight	-5 hours	7 am
CST - Central Standard MDT - Mountain Daylight	-6 hours	6 am
MST - Mountain Standard PDT - Pacific Daylight	-7 hours	5 am
PST - Pacific Standard ADT - Alaskan Daylight	-8 hours	4 am
ALA - Alaskan Standard	-9 hours	3 am
HAW - Hawaiian Standard	-10 hours	2 am
Nome, Alaska	-11 hours	1 am
CET - Central European FWT - French Winter MET - Middle European MEWT - Middle European Winter	+1 hour	1 pm

SWT - Swedish Winter		
EET - Eastern European, Russia Zone 1	+2 hours	2 pm
BT - Baghdad, USSR Zone 2	+3 hours	3 pm
ZP4 - Russia Zone 3	+4 hours	4 pm
ZP5 - Russia Zone 4	+5 hours	5 pm
ZP6 - Russia Zone 5	+6 hours	6 pm
WAST - West Australian Standard	+7 hours	7 pm
CCT - China Coast, USSR Zone 7	+8 hours	8 pm
JST - Japan Standard, Russia Zone 8	+9 hours	9 pm
EAST - East Australian Standard GST Guam Standard, Russia Zone 9	+10 hours	10 pm
IDLE - International Date Line NZST - New Zealand Standard NZT - New Zealand	+12 hours	Midnight

4. **SNTP Sever IP:** Enter the IP address of the SNTP server.
5. **Switch Timer:** Displays the switch's current time
6. **Daylight Saving Period:** Enter the daylight saving time period
7. **Daylight Saving Offset (mins):** Configuring the offset value in minutes
8. Click to active the configuration

[NOTE] If the configuration is not saved, it will be lost when the switch is powered off.

SNTP Configuration

SNTP Client :

Daylight Saving Time :

UTC Timezone	<input type="text" value="(GMT)Greenwich Mean Time: Dublin, Edinburgh, Lisbon, London"/>	
SNTP Server IP	<input type="text" value="0.0.0.0"/>	
Switch Timer	<input type="text"/>	
Daylight Saving Period	<input type="text" value="20040101 00:00"/>	<input type="text" value="20040101 00:00"/>
Daylight Saving Offset(mins)	<input type="text" value="0"/>	

SNTP Configuration

IP Security

IP security function grants 10 specific IP addresses permission to access the switch through a web browser for the switch management.

1. **Enable the IP Security:** Mark the check box to enable
2. **Security IP 1 ~ 10:** Enter up to 10 specific IP address.
3. Click

[NOTE] If the configuration is not saved, it will be lost when the switch is powered off.

IP Security

Enable IP Security

Security IP1	0.0.0.0
Security IP2	0.0.0.0
Security IP3	0.0.0.0
Security IP4	0.0.0.0
Security IP5	0.0.0.0
Security IP6	0.0.0.0
Security IP7	0.0.0.0
Security IP8	0.0.0.0
Security IP9	0.0.0.0
Security IP10	0.0.0.0

Apply Help

IP Security Interface

RSTP Configuration

The Rapid Spanning Tree Protocol (RSTP) is an evolution of Spanning Tree Protocol (STP). It provides a faster spanning tree convergence after a topology change. The switch will auto detect a device that is running STP or RSTP protocol.

System Configuration

Modify RSTP state parameters

- **RSTP mode:** Enable or disable RSTP function.
- **Priority (0-61440):** a value used to identify the root bridge. The bridge with the lowest value has the highest priority and is selected as the root. If the value changes, the switch must be rebooted. The priority value must be multiple of 4096 according to the protocol standard rule.
- **Max Age (6-40):** the number of seconds a bridge waits without receiving Spanning-tree Protocol configuration messages before attempting a reconfiguration. Enter a value between 6 and 40.

- **Hello Time (1-10):** The time that the control switch sends out a BPDU packet to check RSTP status. Enter a value between 1 and 10.
- **Forward Delay Time (4-30):** The number of seconds a port waits before changing from its Rapid Spanning-Tree Protocol learning and listening states to the forwarding state. Enter a value between 4 through 30.
- Click

[NOTE]

1. Use the following rule to configure the MAX Age, Hello Time, and Forward Delay Time.

$$2 \times (\text{Forward Delay Time value} - 1) \geq \text{Max Age value} \geq 2 \times (\text{Hello Time value} + 1)$$

If the configuration is not saved it will be lost when the switch is powered off.

Rapid Spanning Tree

System Configuration | Per Port Configuration

RSTP Mode	Disable
Priority (0-61440)	32768
Max Age (6-40)	20
Hello Time (1-10)	2
Forward Delay Time (4-30)	15

Priority must be a multiple of 4096
 $2 \times (\text{Forward Delay Time} - 1)$ should be greater than or equal to the Max Age.
 The Max Age should be greater than or equal to $2 \times (\text{Hello Time} + 1)$.

Root Bridge Information

Bridge ID	N/A
Root Priority	N/A
Root Port	N/A
Root Path Cost	N/A
Max Age	N/A
Hello Time	N/A
Forward Delay	N/A

RSTP– System Configuration Interface

Per Port Configuration

Configure path cost and priority of every port

1. Select the port in Port column
2. **Path Cost:** The cost of the path to the other bridge from this transmitting bridge at the specified port. Enter a number 1 through 200000000
3. **Priority:** Network Priority. Enter a number from 0 to 240. The value must be a multiple of 16
4. **Admin P2P:** Some of the rapid state transactions that are possible within RSTP are dependent upon whether the port concerned can only be connected to one other bridge (i.e. it is served by a point-to-point LAN segment), or whether it can be connected to two or more bridges (i.e. it is served by a shared medium LAN segment). This function allows the P2P status of the link to be manipulated administratively. True is P2P enabling. False is P2P disabling
5. **Admin Edge:** The port directly connected to end stations cannot create a bridging loop. To configure the port as an edge port, set the port to "True" status
6. **Admin Non Stp:** The port includes the STP mathematic calculation. **True** does not include the STP mathematic calculation. **False** includes the STP mathematic calculation
7. Click

[NOTE] If the configuration is not saved, it will be lost when the switch is powered off.

Rapid Spanning Tree

System Configuration

Per Port Configuration

Port	Path Cost (1-200000000)	Priority (0-240)	Admin P2P	Admin Edge	Admin Non Stp
Port.01					
Port.02					
Port.03	200000	128	Auto	True	False
Port.04					
Port.05					

priority must be a multiple of 16

Apply Help

RSTP Port Status

Port	Path Cost	Port Priority	Admin P2P	Admin Edge	Stp Neighbor	State	Role
Port.01	200000	128	True	True	False	Disabled	Disabled
Port.02	200000	128	True	False	True	Forwarding	Root
Port.03	200000	128	True	True	False	Disabled	Disabled
Port.04	200000	128	True	True	False	Disabled	Disabled
Port.05	200000	128	True	True	False	Disabled	Disabled

RSTP – Per Port Configuration interface

X-Ring

X-Ring provides network redundancy similar to the Spanning Tree and Rapid Spanning Tree Protocols. However, recovery time is greatly reduced when the X-Ring protocol is used. The protocol identifies one switch as the Ring Master. Packets are blocked from the redundant path unless a ring member becomes disconnected from the rest of the network. When this happens, the protocol automatically restores connectivity using the redundant path.

In the X-Ring topology, every switch should enable X-Ring function and assign two member ports to the ring. Only one switch in the X-Ring group would be set as the backup switch. Other switches are called working switches and their two member ports are called working ports. If a network connection failure occurs, the backup port will automatically become a working port to recover.

The switch has a Dipswitch to configure the switch as the ring master. The

ring master has the rights to negotiate and place a command to other switches in the X-Ring group. If more than one switch is in master mode, the software will select the switch with lowest MAC address number as the ring master. An LED on the front panel indicates that the switch is the ring master.

Coupling ring is used to connect 2 or more X-Ring groups providing a redundant back-up Dual homing is used to recover from a connection loss between an X-Ring group and the upper level/core switch.

- **Enable X-Ring:** Mark the check box to enable the X-Ring function
- **1st & 2nd Working Ports:** Assign two ports as the member ports. One port will be working port and one port will be the backup port. The system will automatically decide which port is working port and which port is backup port
- **Enable Coupling Ring:** Mark the check box to enable the coupling ring function
- **Coupling port:** Assign the member port
- **X-Ring Master:** Set the switch labeled RM on front panel to on position. This establishes that switch as a master for the ring.
- **Enable Dual Homing:** Set up one of port to be the Dual Homing port. In an X-Ring group, only one can be a Dual Homing port. This function will only work when the X-Ring function is enabled
- Click

X-Ring

Enable X-Ring
1st Working Port
2nd Working Port

Enable Couple Ring
Coupling Port
Control Port

Enable Dual Homing

X-Ring Interface

[NOTE]

1. When the X-Ring function is enabled, the RSTP function must be disabled.
 2. **If the configuration is not saved, it will be lost when the switch is powered off.**
-

QoS Configuration

- **Qos Policy:** select the Qos policy rule
 - **Using the 8,4,2,1 weight fair queue scheme:** The switch will follow 8:4:2:1 rate to process priority queue from Highest to lowest. For example: the system will process 8 high queue packets, 4 middle queue packets, 2 low queue packets, and one lowest queue packets at the same time
 - **Use the strict priority scheme:** The highest queue will always be processed first.
- **Priority Type:** Every port has 5 priority types
 - **Port-base:** The port priority will follow the **default port priority** assigned – High, middle, low, or lowest
 - **COS only:** The port will follow the **COS priority** assigned
 - **TOS only:** The port will follow the **TOS priority** assigned
 - **COS first:** The port will follow COS priority first, and then another priority rule
 - **TOS first:** The port will follow TOS priority first, and then another priority rule
- **COS priority:** Set the COS priority level 0~7
- **TOS priority:** The system provides 0 to 63 TOS priority levels. Each level has 4 types of priority – high, mid, low, and lowest. The default value is “Lowest”. When the IP packet is received, the system will check the TOS value.

[NOTE] QoS and Rate control cannot be used simultaneously.

QoS

Qos Policy

- Use an 8,4,2,1 weighted fair queuing scheme
- Use a strict priority scheme

Priority Type:

Port.01	Port.02	Port.03	Port.04	Port.05
Port-based ▾	Port-based ▾	Port-based ▾	Port-based ▾	Port-based ▾

Default Port Priority:

Port.01	Port.02	Port.03	Port.04	Port.05
Lowest ▾	Lowest ▾	Lowest ▾	Lowest ▾	Lowest ▾

Apply Help

COS

Priority	0	1	2	3	4	5	6	7
	Lowest ▾	Lowest ▾	Lowest ▾	Lowest ▾	Lowest ▾	Lowest ▾	Lowest ▾	Lowest ▾

Apply Help

TOS

Priority	0	1	2	3	4	5	6	7
	Lowest ▾	Lowest ▾	Lowest ▾	Lowest ▾	Lowest ▾	Lowest ▾	Lowest ▾	Lowest ▾
Priority	8	9	10	11	12	13	14	15
	Lowest ▾	Lowest ▾	Lowest ▾	Lowest ▾	Lowest ▾	Lowest ▾	Lowest ▾	Lowest ▾
Priority	16	17	18	19	20	21	22	23
	Lowest ▾	Lowest ▾	Lowest ▾	Lowest ▾	Lowest ▾	Lowest ▾	Lowest ▾	Lowest ▾
Priority	24	25	26	27	28	29	30	31
	Lowest ▾	Lowest ▾	Lowest ▾	Lowest ▾	Lowest ▾	Lowest ▾	Lowest ▾	Lowest ▾
Priority	32	33	34	35	36	37	38	39
	Lowest ▾	Lowest ▾	Lowest ▾	Lowest ▾	Lowest ▾	Lowest ▾	Lowest ▾	Lowest ▾
Priority	40	41	42	43	44	45	46	47
	Lowest ▾	Lowest ▾	Lowest ▾	Lowest ▾	Lowest ▾	Lowest ▾	Lowest ▾	Lowest ▾
Priority	48	49	50	51	52	53	54	55
	Lowest ▾	Lowest ▾	Lowest ▾	Lowest ▾	Lowest ▾	Lowest ▾	Lowest ▾	Lowest ▾
Priority	56	57	58	59	60	61	62	63
	Lowest ▾	Lowest ▾	Lowest ▾	Lowest ▾	Lowest ▾	Lowest ▾	Lowest ▾	Lowest ▾

Apply Help

QoS configuration Interface

IGMP

The Internet Group Management Protocol (IGMP) is an internal protocol of the Internet Protocol (IP) suite. IP manages multicast traffic by using switches, routers, and hosts that support IGMP. Enabling IGMP allows the ports to detect IGMP queries and report packets and manage IP multicast traffic through the switch. IGMP has three fundamental types of messages:

Message	Description
Query	A message sent from an IGMP router or switch requesting a response from each host belonging to the multicast group.
Report	A message sent by a host indicating that the host wants to be or is a member of a given group.
Leave Group	A message sent by a host indicating that the host has is no longer a member of a specific multicast group.

[NOTE] If the configuration is not saved, it will be lost when the switch is powered off.

IGMP

IP Address _____ VLAN ID _____ Member Port _____

235.080.068.083 _____ 1 _____ ****6**

IGMP Protocol:

IGMP Query :

IGMP Snooping interface

Security Manager

Use to change the web management login user name and password.

1. **User name:** enter the new user name(The default is "root")
2. **Password:** enter the new password(The default is "root")
3. **Confirm password:** reenter the new password
4. Click

[NOTE] If the configuration is not saved, it will be lost when the switch is powered off.

Security Manager

User Name :

New Password :

Confirm Password :

Security Manager Interface

Configuration Backup

Used to backup the configuration to a TFTP server and load the backup configuration from the TFTP server.

TFTP Restore Configuration

Restore flash ROM value from the TFTP server.

1. **TFTP Server IP Address:** Enter the TFTP server IP
2. **Restore File Name:** Enter the file name
3. Click

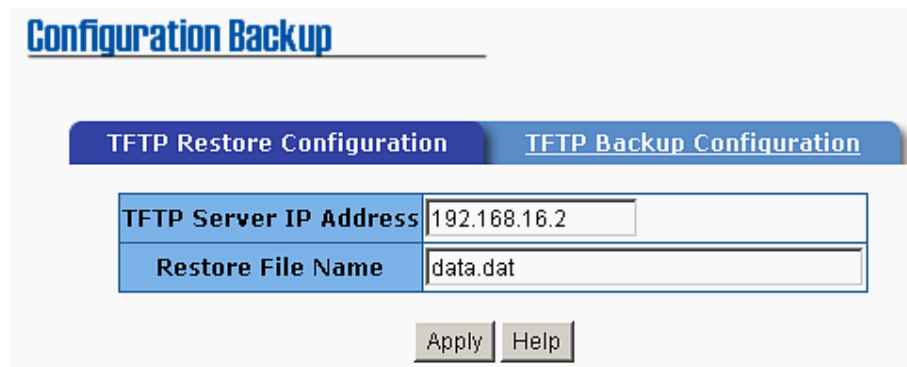

The screenshot shows a web-based configuration interface. At the top, there is a header 'Configuration Backup' with a blue underline. Below this, there are two tabs: 'TFTP Restore Configuration' (which is active and highlighted in blue) and 'TFTP Backup Configuration'. Under the active tab, there are two input fields. The first is labeled 'TFTP Server IP Address' and contains the text '192.168.16.2'. The second is labeled 'Restore File Name' and contains the text 'data.dat'. Below these fields are two buttons: 'Apply' and 'Help'.

TFTP Restore Configuration interface

TFTP Backup Configuration

Save current flash ROM value to the TFTP server

1. **TFTP Server IP Address:** Enter the TFTP server IP
2. **Backup File Name:** Enter the file name
3. Click

Configuration Backup

TFTP Restore Configuration	TFTP Backup Configuration
TFTP Server IP Address	192.168.10.2
Backup File Name	data.dat
<input type="button" value="Apply"/> <input type="button" value="Help"/>	

TFTP Backup Configuration interface

TFTP Update Firmware

Use to update firmware. Ensure the TFTP server is ready and the firmware image is stored on the TFTP server,

1. **TFTP Server IP Address:** Enter the TFTP server IP Address
2. **Firmware File Name:** Enter the name of firmware image
3. Click

TFTP Update Firmware

TFTP Server IP Address	192.168.16.2
Firmware File Name	image.bin
<input type="button" value="Apply"/> <input type="button" value="Help"/>	

TFTP Update Firmware interface

Factory Default

Reset the Switch to the default configuration. **NOTE: The IP Address, subnet mask, default gateway, username, and password will remain as configured by the user.**

- Click 

Factory Default

Please click **[Default]** button to restore factory default setting.

Factory Default interface

System Reboot

Reboot the switch in software reset

- Click 

System Reboot

Please click **[Reboot]** button to restart switch device.



System Reboot interface

Save Configuration

Save the configuration to flash memory. If the switch is powered off without saving the configuration, all changed configuration will lost

- Click 

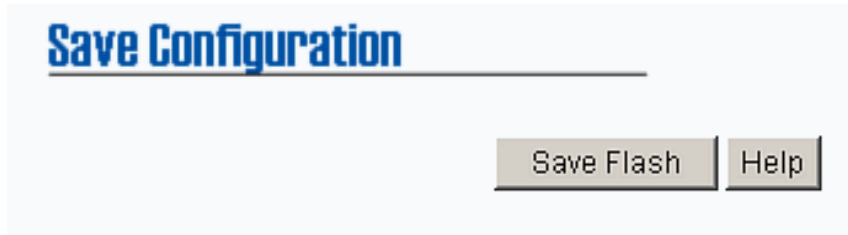

Save Configuration Interface

Rate Control

Set up each port's bandwidth rate and packet limitation type

- **Limit Packet type:** Select the packet type to filter. The packet filter types are all packet types, broadcast/multicast/unknown, unicast packets, broadcast/multicast packets, and broadcast packet only. The broadcast/multicast/unknown, unicast packet, broadcast/multicast packet, and broadcast packet only are only for ingress. The egress rate only supports all packet types.
- Ports 1 through 5 support port ingress and egress rate control. For example, assume port 1 is 10Mbps, users can set its effective egress rate to 1Mbps, and the ingress rate to 500Kbps.
 - **Ingress:** Select the port effective ingress rate. The valid range value is 1MB, 2MB, 4MB, 8MB, 16MB, 32MB and 64MB. The default value is "disable"
 - **Egress:** Select the port effective ingress rate. The valid range value is 128kbps, 256Kbps, 512Kbps, 1MB, 2MB, 4MB, and 8MB. The default value is "disable"

- Click 

[NOTE] If the configuration is not saved, it will be lost when the switch is powered off.

[NOTE] QOS and Rate control cannot exist at the same.

Rate Control

	Limit packet type	Ingress	Egress
Port.01	All	Disable	Disable
Port.02	All	Disable	Disable
Port.03	All	Disable	Disable
Port.04	All	Disable	Disable
Port.05	All	Disable	Disable

Apply Help

Rate Control Interface

Trouble shooting

- Verify the power supply is correct (12-48V DC) Do not exceed 48V DC.
- Ensure the proper UTP cable is used for RJ-45 connections: 100Ω Category 3, 4 or 5 cable for 10Mbps connections or 100Ω Category 5 cable for 100Mbps connections. Ensure that the length of any twisted-pair connection does not exceed 328 feet (100 meters).
- **LED Indicators:** Assist in identifying problems.

Technical Specification

Standards	<p>IEEE 802.3 10Base-T Ethernet</p> <p>IEEE 802.3u 100Base-TX Fast Ethernet</p> <p>IEEE802.3x Flow Control and Back-pressure</p> <p>IEEE802.1d spanning tree / IEEE802.1w rapid spanning tree</p> <p>IEEE802.1p class of service</p> <p>IEEE802.1Q VLAN Tag</p>
Protocol	CSMA/CD
Management	Provides Web interface management and one default button for system default setting
Technology	Store and forward switching architecture
Transfer Rate	<p>14,880 pps for Ethernet port</p> <p>148,800 pps for Fast Ethernet port</p>
Transfer packet size	64bytes to 1522 bytes (with VLAN tag)
MAC address	2K MAC address table
Memory Buffer	1Mbits
Back-plane	1.0 Gbps
Packet throughput ability	1.49Mpps @64bytes (4TX +1 FX)

LED	Per port: Link/Activity (Green), Full duplex/Collision (Yellow) Per unit: Power (Green), Power 1 (Green), Power 2 (Green), Fault (Yellow), Master (Green)
Network Cable	10Base-T: 2-pair UTP/STP Cat. 3, 4, 5 cable EIA/TIA-568 100-ohm (100m) 100Base-TX: 2-pair UTP/STP Cat. 5 cable EIA/TIA-568 100-ohm (100m)
Optical cable	SC (Multi-mode): 50/125um~62.5/125um SC (Single mode): 9/125um~10/125um Available distance: 2KM (Multi-mode) / 30KM (single-mode) Wavelength: 1310nm (multi-mode/ single mode)
Power Supply	Redundant 12 to 48 V DC power inputs with reverse polarity protection
Power consumption	3.64 Watts
Packet filter	4 selection rules : <ul style="list-style-type: none"> ■ All packets ■ Broadcast/ multicast/ unknown unicast packets ■ Broadcast/ multicast packets ■ Broadcast packets only
Class of service	IEEE802.1p class of service support, 4 priority queues per port.

Quality of service	port based Tag based IPv4 Type of service
X-Ring	300 ms Recovery Time
VLAN	Port based VLAN and IEEE802.1Q Tag VLAN. Both port based and Tag based VLAN groups (up to 64).
Spanning tree	IEEE802.1d spanning tree and IEEE802.1w rapid spanning tree.
IGMP	IGMP v1 and Query mode. Up to 256 groups.
SNTP	Simple Network time protocol
Management IP security	IP address security to prevent intrusion
Port mirror	TX packet only or both TX and RX packet.

Install	DIN rail and panel mount
Alarm	Relay output for port breakdown and power source failure. Alarm Relay Contact Rating: 1A @ 24 VDC Contacts normally open
Firmware update	TFTP firmware update TFTP configuration backup and restore.
DHCP client	DHCP client function to obtain the IP address from a DHCP server.
Bandwidth control	<ul style="list-style-type: none"> ■ Ingress packets filter and egress packet limit ■ The egress rate control supports all of packet type and the limit rates are 128kbps, 256Kbps, 512Kbps, 1MB, 2MB, 4MB, and 8MB ■ Ingress filter packet type combination rules are Broadcast/Multicast/Unknown Unicast packet, Broadcast/Multicast packet, Broadcast packet only and all of packet. The packet filter rate can be set follow as:1Mbps、2Mbps、4Mbps、8Mbps、16Mbps、32Mbps、64Mbps
Operation Temp.	0°C to 60°C (32°F to 140°F)
Operation Humidity	5% to 95% (Non-condensing)
Storage Temperature	-40°C to 85°C
Case	IP-30

Dimensions	2.3 x 5.7 x 4.3 in (5.8 x 14.5 x 10.9 cm)
EMI	FCC Class A, CE EN6100-4-2, CE EN6100-4-3, CE EN-6100-4-4, CE EN6100-4-5, CE EN6100-4-6
Safety	EN60950
Stability testing	IEC60068-2-32 (Free fall), IEC60068-2-27 (Shock), IEC60068-2-6 (Vibration)