



EIR405-SFP-T

User Manual



EIR405-SFP-T

Documentation Number: EIR405-SFP-T-0109m



International Headquarters

B&B Electronics Mfg. Co. Inc.

707 Dayton Road

Ottawa, IL 61350 USA

Phone (815) 433-5100 -- **General Fax** (815) 433-5105

Website: www.bb-elec.com

European Headquarters

B&B Electronics Ltd.

Westlink Commercial Park

Oranmore, Co. Galway, Ireland

Phone +353 91-792444 -- **Fax** +353 91-792445

Website: www.bb-europe.com

©2008 B & B Electronics Mfg. Co. Inc. No part of this publication may be reproduced or transmitted in any form or by any means, electronic or mechanical, including photography, recording, or any information storage and retrieval system without written consent. Information in this manual is subject to change without notice, and does not represent a commitment on the part of B&B Electronics Mfg. Co. Inc.

B&B Electronics Mfg. Co. Inc. shall not be liable for incidental or consequential damages resulting from the furnishing, performance, or use of this manual.

All Brand names used in this manual are the registered trademarks of their respective owners. The use of trademarks or other designations in this publication is for reference purposes only and does not constitute an endorsement by the trademark holder

Table of Contents

1. Overview	1
<i>Introduction</i>	<i>1</i>
<i>Features</i>	<i>2</i>
<i>Packing List</i>	<i>2</i>
2. Hardware Description	3
<i>Front Panel</i>	<i>3</i>
<i>Top View</i>	<i>4</i>
<i>Wiring the Power Inputs</i>	<i>4</i>
<i>Wiring the Fault Alarm Contact</i>	<i>5</i>
<i>LED Indicators</i>	<i>6</i>
<i>Ports</i>	<i>6</i>
<i>Cabling</i>	<i>7</i>
3. Mounting Installation	12
<i>DIN-Rail Mounting</i>	<i>12</i>
<i>Wall Mount Plate Mounting</i>	<i>14</i>
4. Hardware Installation	15
Installation Steps	16
5. Trouble shooting	17
6. Technical Specification	18

Overview

Introduction

The EIR405-SFP-T is an industrial DIN mount, unmanaged 5 port Gigabit Ethernet switch. It has (4) 10/100/1000 copper Ethernet ports and (1) SFP slot used for Gigabit fiber options.

The SFP Advantage

The SFP fiber slot provides flexibility when planning and implementing a network. The SFP slot can accept any SFP-type fiber module and is capable of transmitting distances of 500m in (multi-mode) and 10km, 20km, and greater in (single-mode). The SFP slot also supports SFP modules used for WDM single-fiber transmissions. This means that you can easily change the transmission mode and distance of the switch by simply pulling out the SFP module and plugging in a different module. The SFP modules are hot-swappable and plug-and-play.

High-Speed Transmissions

The EIR405-SFP-T includes a switch controller that can automatically sense transmission speeds (10/100/1000 Mbps). The RJ-45 interface can also be auto-detected, so MDI or MDI-X is automatically selected and a crossover cable is not required. All Ethernet ports have memory buffers that support the store-and-forward mechanism. This assures that data is properly transmitted

Dual Power Input

To reduce the risk of power failure, the EIR405-T provides two 12 to 48 VDC power inputs. If the power fails, the switch will automatically switch to the secondary power input. Also if the power goes out the corresponding P1 or P2 LED will go out and the Fault LED will light. The contacts for the alarm output will also open.

Flexible Mounting

The EIR405-SFP-T can be DIN or Panel mounted. The compact design is suitable for space-constrained environments such as a small cabinet.

Advanced Protection

The power line input on the EIR405-SFP-T supports up to 3,000 VDC EFT protection, which secures the equipment against unregulated voltages and makes the system safer and more reliable. The Ethernet ports support up to 4,000 VDC ESD protections which makes the switch suitable for harsh environments.

Wide Operating Temperature

The operating temperature of the EIR405-SFP-T is -40 to 75°C. This wide range allows the switch to be used in some of the harshest industrial environments that exist.

Easy Troubleshooting

LED indicators make troubleshooting quick and easy. There are 2 LED's for each port that display the link status and transmission speed. Three LED's P1, P2 and Fault help you diagnose if power is present.

Features

- Provides 4 x 10/100/1000Base-T Mbps Ethernet ports
- Provides 1 x SFP (mini-GBIC) port
- Supports full/half duplex flow control
- Supports auto-negotiation (10/100/1000)
- Supports MDI/MDI-X auto-crossover
- Supports MAC Address up to 8Kbytes
- Supports Jumbo Frame of 9Kbytes
- Supports surge (EFT) protection 3,000 VDC for power input
- Supports 4,000 VDC Ethernet ESD protection
- Supports redundant 12 to 48 VDC power inputs
- Provides flexible mounting: DIN-rail, Panel Mounting
- Supports operating temperatures from -40 to 75°C

Packing List

- EIR405-SFP-T, 5 Port Gigabit Industrial Ethernet Switch
- Quick Start Guide
- CD ROM with User Manual
- Wall Mounting Bracket and Screws

Hardware Description

Front Panel

The Front Panel of the EIR405-SFP-T is shown below.

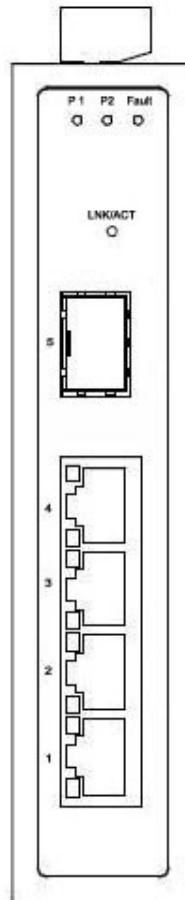

Top View

The top panel view of the EIR405-SFP-T is equipped with one terminal block connector that consists of two 12 to 48 VDC power inputs and the fault alarm output.

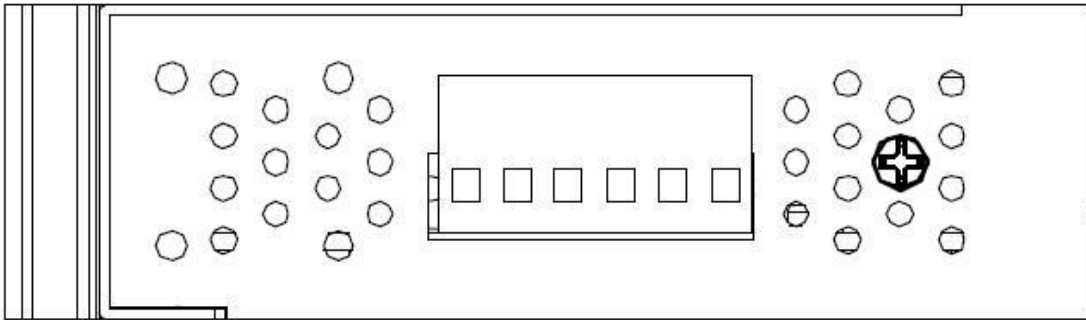

Wiring the Power Inputs

Follow the steps below to insert the power wires.

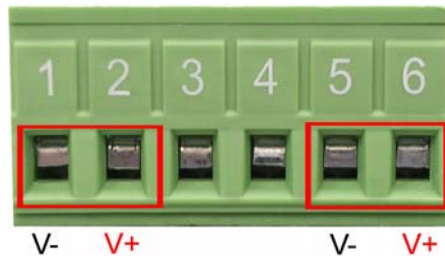

1. Insert the positive and negative wires into the V+ and V- contacts on the terminal block connector.

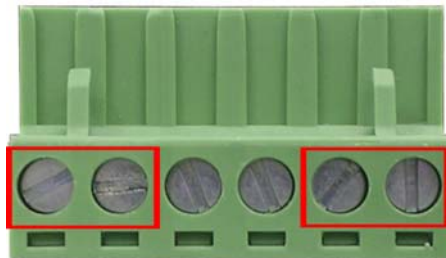

2. Tighten the wire-clamp screws to prevent the wires from becoming loose.

Wiring the Fault Alarm Contact

The fault alarm contact is in the middle of terminal block connector as shown below. If one of the power sources fails a fault will be detected causing the circuit to open.



Insert the wires into the fault alarm contact (No. 3 & 4)

Note *The wire gauge for the terminal block should be 12 to 24 AWG.*

LED Indicators

Below is a table that explains the status of each the power and network status LED's found on the front panel of the EIR405-SFP-T.

LED	Color	Description	
P1	Green	On	Power input 1 is active
		Off	Power input 1 is inactive
P2	Green	On	Power input 2 is active
		Off	Power input 2 is inactive
Fault	Red	On	Power input 1 or 2 is inactive
		Off	Power input 1 and 2 are both functional, or no power is applied
LNK/ACT (SFP)	Green	On	Connected to network
		Flashing	Networking is active
		Off	Not connected to network
Ports 1 to 4 (Upper LED)	Green	On	Connected to network
		Flashing	Networking is active
		Off	Not connected to network
Ports 1 to 4 (Lower LED)	Green	On	Connected to network at speeds of 1000Mbps
		Off	Not connected to network

Ports

RJ-45 ports: The RJ-45 ports auto-sense for 10, 100 or 1000 Mbps devices connections. The auto MDI/MDIX feature allows connections to switches, workstation and other equipment without changing straight through or crossover cabling. The charts below show the cable pin assignments for straight through and crossover cables.

■ RJ-45 Pin Assignments

Pin Number	Assignment
1	Tx+
2	Tx-
3	Rx+
6	Rx-

Note "+" and "-" signs represent the polarity of each wire pair.

All copper ports on the EIR405-SFP-T support automatic MDI/MDI-X operation, you can use straight-through cables (See Figure below) for all network connections to PCs or servers, or to other switches or hubs. In straight-through cables, pins 1, 2, 3, and 6, at one end of the cable, are connected straight through to pins 1, 2, 3 and 6 at the other end of the cable. The table below shows the 10BASE-T / 100BASE-TX MDI and MDI-X port pin outs.

Pin	MDI-X Signal Name	MDI Signal Name
1	Receive Data plus (RD+)	Transmit Data plus (TD+)
2	Receive Data minus (RD-)	Transmit Data minus (TD-)
3	Transmit Data plus (TD+)	Receive Data plus (RD+)
6	Transmit Data minus (TD-)	Receive Data minus (RD-)

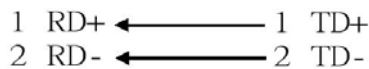
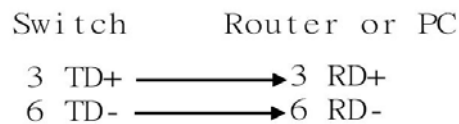

Straight Through Cable Schematic

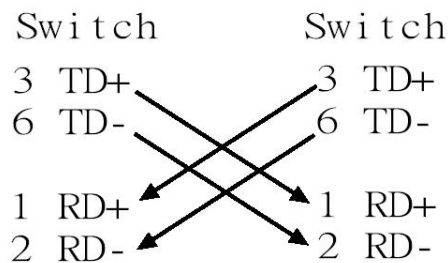

Cross Over Cable Schematic

Cabling

Use unshielded twisted-pair (UTP) or shielded twisted-pair (STP) cable.

10Mbps: Use category 3, 4, 5 or greater cable

100Mbps: Use category 5 or greater

1000Mbps: Use category 5e or greater cable

Cable distances should be less than 100 meters (328 ft.) long.

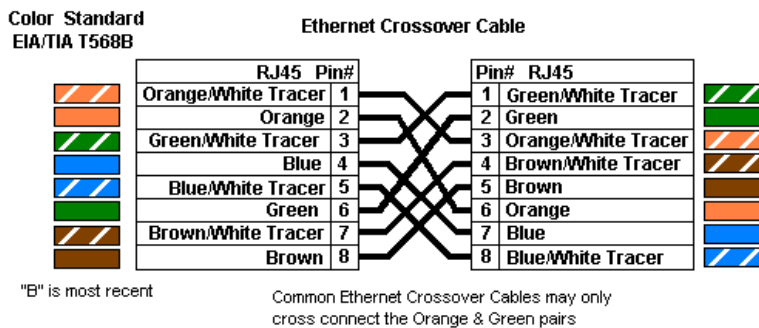
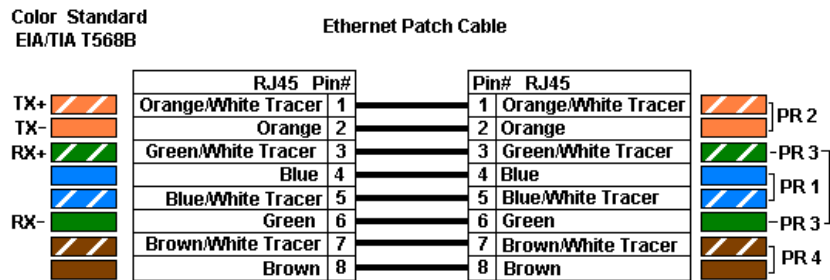
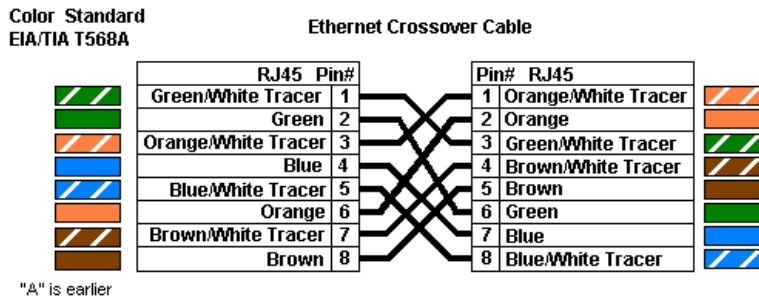
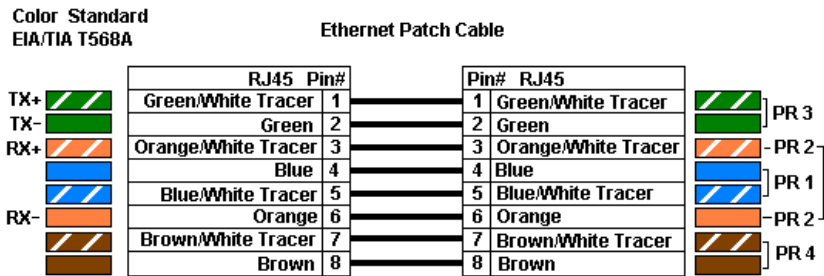
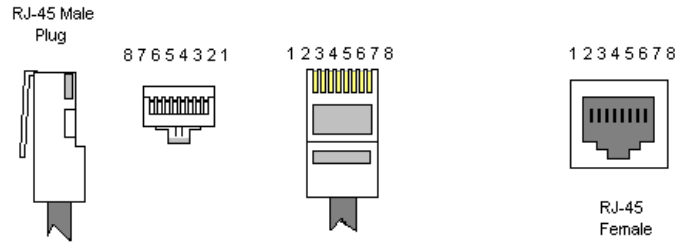

The small form-factor pluggable (SFP) is a compact optical transceiver.

To connect the transceiver and fiber cable, follow the steps below. (Note: SFP modules typically terminate with an LC fiber connector)

First, insert the SFP transceiver into the SFP module cage. Notice that the triangle mark is at the bottom of the module.

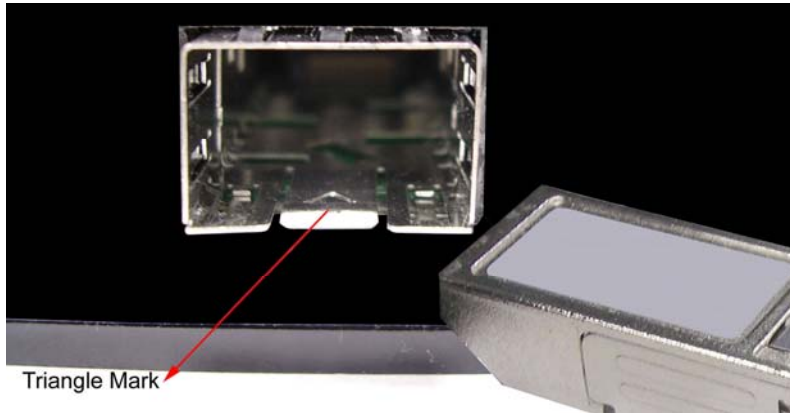

Transceiver Inserted

Second, insert the fiber cable into the transceiver.

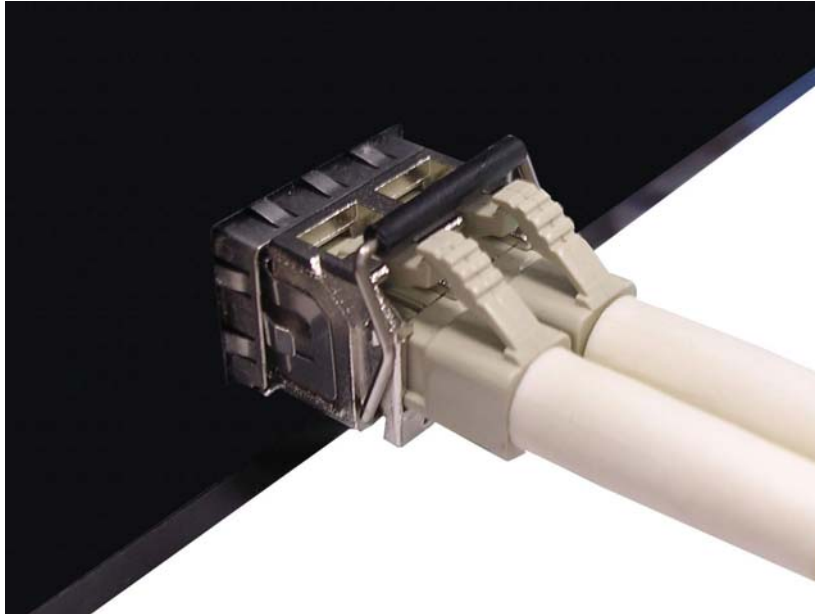

LC fiber cable shown installed into the transceiver

Removing the LC fiber cable and SFP transceiver, follow the steps below:

First, press the upper side of the LC connector down and pull it out before releasing.

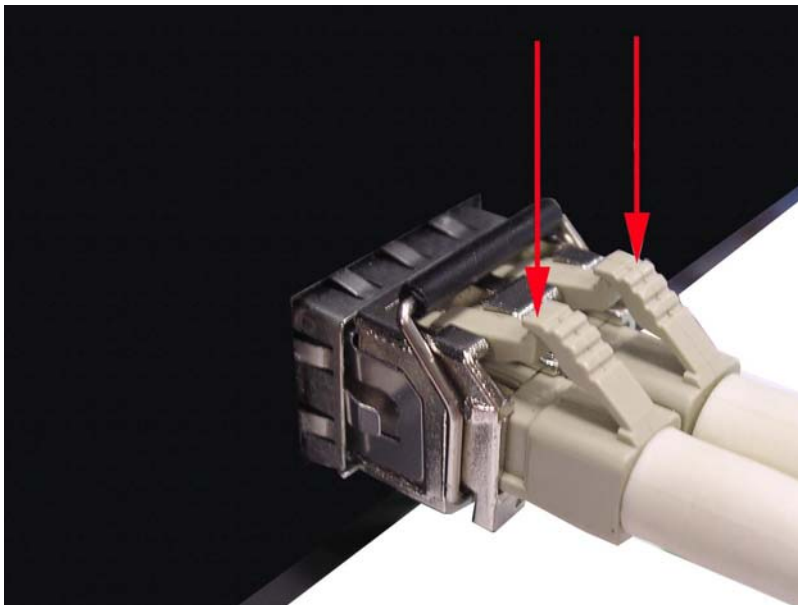

Remove LC connector

Second, swivel the metal latch away from the switch and pull the transceiver out.

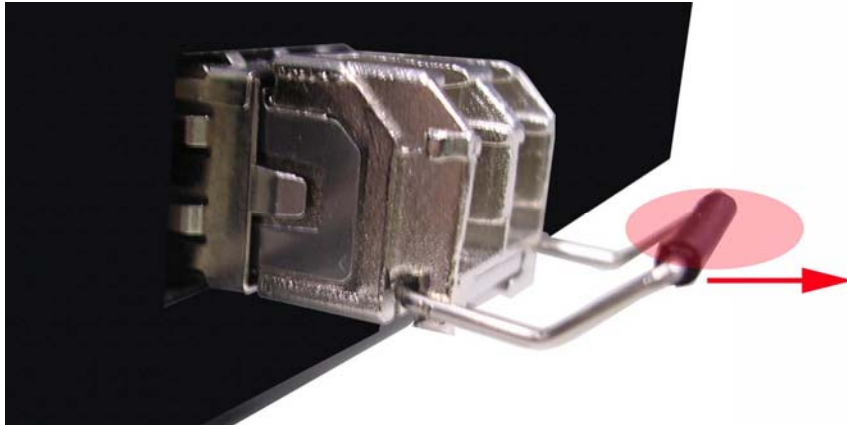

Pull out the SFP module

Mounting Installation

DIN-Rail Mounting

The DIN rail clip comes screwed on to the switch, from the factory. If the DIN rail clip is not screwed on the switch, please see the following figure to re-attach the DIN-Rail clip. Then follow the steps below to hang the switch onto a DIN rail.

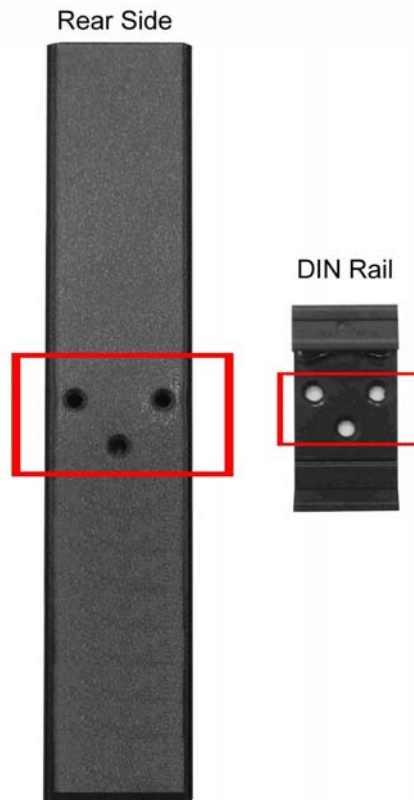

1. Use the screws to screw the DIN rail clip onto switch.
2. To remove the DIN rail clip, reverse step 1.

3. First, insert the top of DIN rail clip onto the piece DIN rail track.



4. Then, lightly push the bottom of the switch so it can snap the rest of the way onto the DIN rail track.

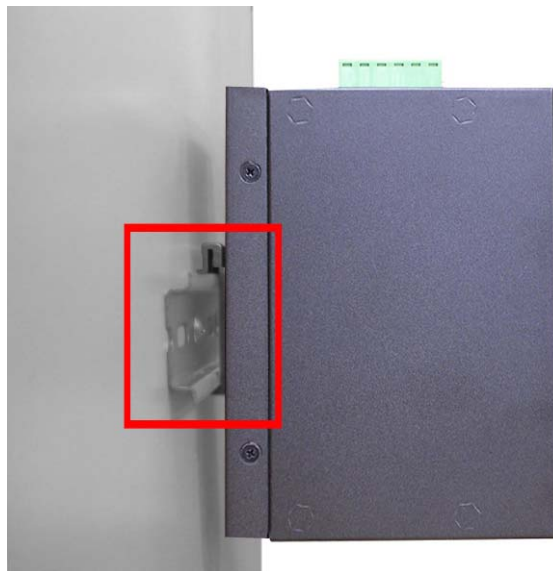

5. Check that the switch is held tightly to the DIN rail track.

6. To remove the switch from the track, reverse the steps above.
 - First pushing down lightly on the switch will give enough room for the bottom of the switch to clear the bottom of the DIN rail track.
 - Pulling slowly at the bottom of the switch will bring the switch out so that the switch can now be carefully lifted off the DIN rail track.

Wall or Panel Mount Plate Mounting

Follow the steps below to mount the switch with the wall mount plates.

1. Remove the DIN rail clip from the switch; loosen the screws to remove the DIN rail clip.
2. Place the wall mount plate on the side panels of the switch.
3. Use the screws to screw the wall mount plate onto switch.
4. Use the hook holes at the corners of the wall mount plates to hang the switch on the wall.
5. To remove the wall mount plate, reverse the above steps.

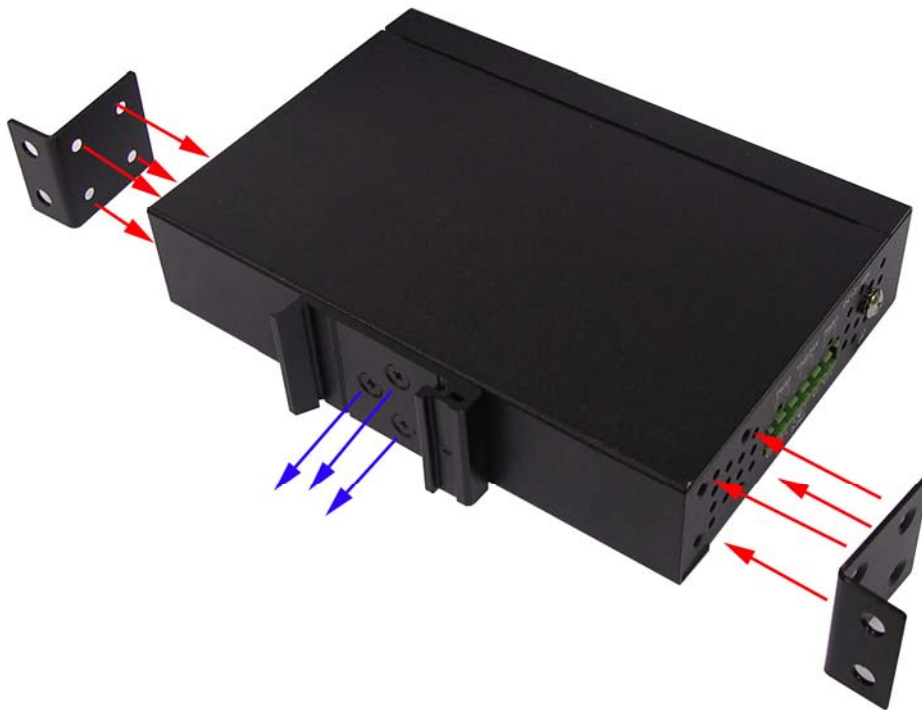

Hardware Installation

The diagram below shows a typical switch installation for the EIR405-SFP-T.

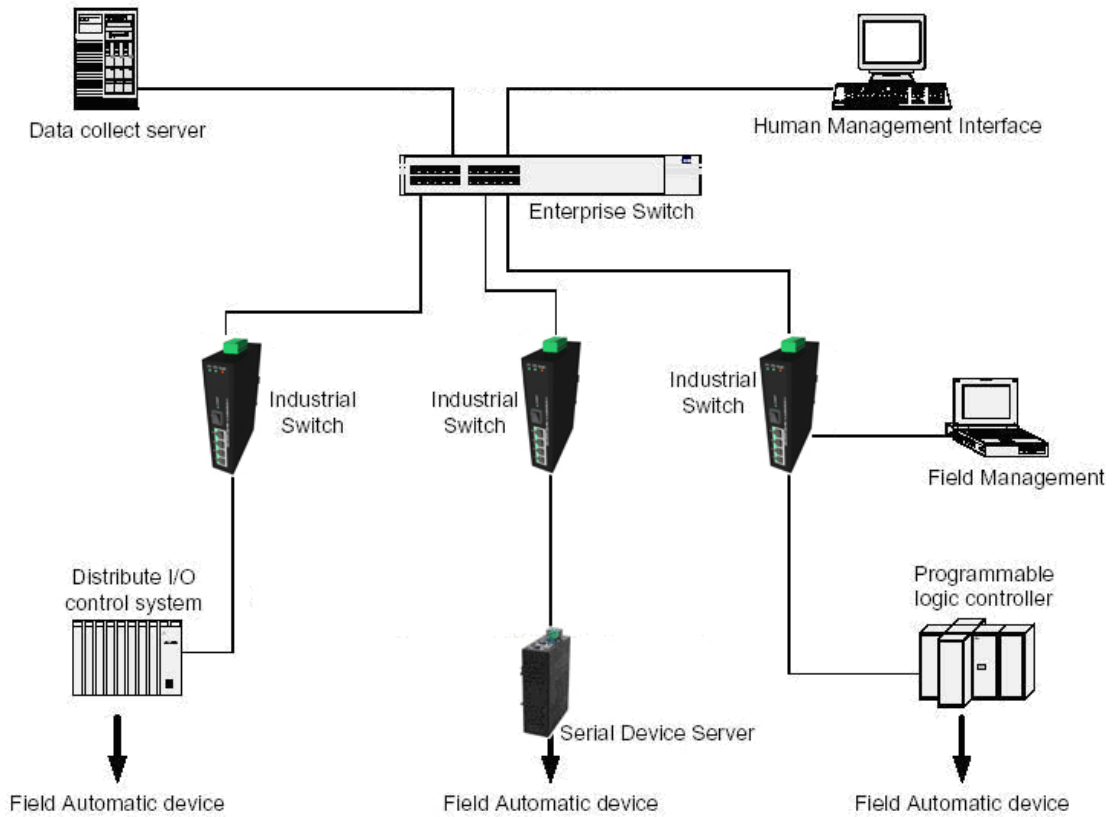

Installation Steps

1. Unpack the switch.
2. Check that the DIN rail clip is screwed onto the switch. If the DIN rail clip is not screwed onto the switch, please refer to **DIN-Rail Mounting** section for DIN-Rail installation. If you want to wall or panel mount the switch, then please refer to **Wall or Panel Mount Plate Mounting** section for wall place installation.
3. Apply power to the switch. If you need help with this please refer to the **Wiring the Power Inputs** section. The power LED on the switch will light up. Please refer to the **LED Indicators** section for meaning of LED lights.
4. Prepare the twisted-pair, Ethernet cable for connection.
5. Insert one side of cable into one of the switches Ethernet ports and the other side of the cable to the network device you want connected ex: switch, PC or Server. The port LED on the Industrial switch will light up when the cable is connected to the network device. Please refer to the **LED Indicators** section for LED light meaning.
6. When all connections are made and the LED lights show normal activity the installation is complete.

Trouble shooting

- Verify that you are using a power supply ranging from 12 to 48VDC. Applying more than 48VDC could cause damage to the switch.
- Be sure the proper cable is used in your network. Refer to the **Cabling** section of this manual for help.
- **Diagnosing LED Indicators:** The switch can be monitored through the LED indicators on the front panel of the switch. The LED's can help describes common problems you may encounter and where you may find possible solutions, to assist in identifying problems.
- If the power indicators do not light on when power is applied, you may have a problem with the power supply. Check for loose power connections, power losses or surges at the power outlet.
- If the switch LED's represent normal operating mode and the cable connections are correct and no data is transmitted or received through the switch, contact your Network Administrator for network configuration and status help.

Technical Specification

Communications

Compatibility	IEEE 802.3, 802.3u, 802.3ab IEEE 802.3x, 802.3z
LAN	10/100/1000Base-T, 1000Base-FX
Transmission Speed	Up to 1000 Mbps

Interface

Connectors	4 x RJ-45 (4-port 10/100/1000TX) 1 x SFP port (mini-GBIC port) 6-pin removable screw terminal (power input & fault relay output)
LED Indicators	Unit: P1, P2, Fault Ethernet port: Link/Active, 1000M SFP: Link/Active

Power

Power Consumption	5.50W
Power Input	2 x Unregulated 12 to 48 VDC
Fault Output	1 Relay Output

Mechanism

Dimensions (WxDxH)	30 x 95 x 140 mm (1.2 x 3.7 x 5.5 in.)
Enclosure	IP-30, Metal shell with solid mounting kits
Mounting	DIN rail 35mm or Wall/Panel

Protection

ESD (Ethernet)	4,000 VDC
Surge (EFT for power)	3,000 VDC
Reverse Power	Yes
Overload current protection	Yes

Environment

Operating Temperature	-40 to 75°C (-40 to 167°F)
Operating Humidity	5% to 95% (non-condensing)
Storage Temperature	-40 to 85°C (-40 to 185°F)

Certifications

Safety	UL, cUL, CE EN60950-1
EMC	FCC Class A, CE EN61000-4-2 (ESD) CE EN61000-4-3 (RS) CE EN61000-4-4 (EFT) CE EN61000-4-5 (Surge) CE EN61000-4-6 (CS) CE EN61000-4-8 CE EN61000-4-11 CE EN61000-4-12 CE EN61000-6-2 CE EN61000-6-4
Free Fall	IEC60068-2-32
Shock	IEC60068-2-27
Vibration	IEC60068-2-6