



# RocketPort<sup>®</sup> Serial Hub *ia* (RPSH-ia)

## 2-Port

### *Hardware Documentation*

#### Product Overview

The RocketPort Serial Hub *ia* is a DIN-rail mountable (24V) serial communications device that easily connects to a 10/100 Base-T Ethernet hub, switch, or network interface card (NIC).

The RocketPort Serial Hub *ia* uses a RISC processor to process asynchronous serial communications, thereby maximizing performance and eliminating throughput bottlenecks.

RocketPort Serial Hub *ia* features include:

- Two DB9 software selectable RS-232, RS-422, or RS-485 asynchronous serial ports.
- Configurable network protocol, allowing the RocketPort Serial Hub *ia* to use IP or MAC (media access control) addressing.  
*Note:* See the [Software Installation](#) documentation for MAC or IP addressing information.
- An optional 24VDC power supply that supports input voltages between 100-240VAC and 50 or 60 Hz operation.
- Auto polarity selection for network connection.
- Diagnostic LEDs

Some drivers feature:

- Multi-server port assignment, permitting the sharing of this device with multiple servers. Each individual server can be configured for MAC or IP addressing.
- Port sharing among servers, the same port can be used for multiple servers.

#### What This Document Contains

Use this document to:

- [Install](#) the RocketPort Serial Hub *ia*.
- [Verify](#) that the RocketPort Serial Hub *ia* passes the hardware diagnostics during the power up phase.
- [Add](#) additional units to an existing RocketPort Serial Hub *ia* environment.
- [Build cables or loopback plugs](#), including:
  - An ethernet crossover cable, if connecting the RocketPort Serial Hub *ia* directly to a NIC card (not included).
  - Null-modem cable for the peripheral devices that you are connecting to the RocketPort Serial Hub *ia* (not included).
  - RS-232/422 loopback plug (one included).
- [Troubleshoot](#) installation or configuration problems.
- Review the RocketPort Serial Hub *ia* [specifications](#) and [agency notices](#).
- [Contact](#) Control<sup>™</sup> or download updated software or documentation.

See the appropriate [Software Installation](#) documentation for software installation information.

The latest driver releases are available at:

- <http://www.comtrol.com/coperate.htm>
- <ftp://ftp.comtrol.com>

*Note:* To use the red hyperlinks, you must be connected to the internet.

## Connecting to the Network

Use the following procedure to connect the RocketPort Serial Hub *ia* to your ethernet hub, ethernet switch, or a server's NIC card.

- Record the MAC address, model number, and serial number of the RocketPort Serial Hub *ia* unit on the customer service label provided.

**Note:** You may need the MAC address during driver configuration.

| Serial Number* | MAC*                |
|----------------|---------------------|
|                | 00 C0 4E 11 _ _ _ _ |

\* The serial number and MAC address are located on a label on the side of the unit.

- If you are not planning on mounting this unit to a standard DIN rail, mount the DIN rail section provided with the unit to a wall with suitable screws (not provided).

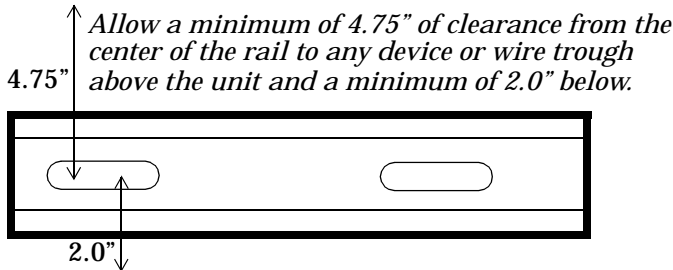

- Attach the RocketPort Serial Hub *ia* to a standard DIN rail or the DIN rail section mounted in Step 2.

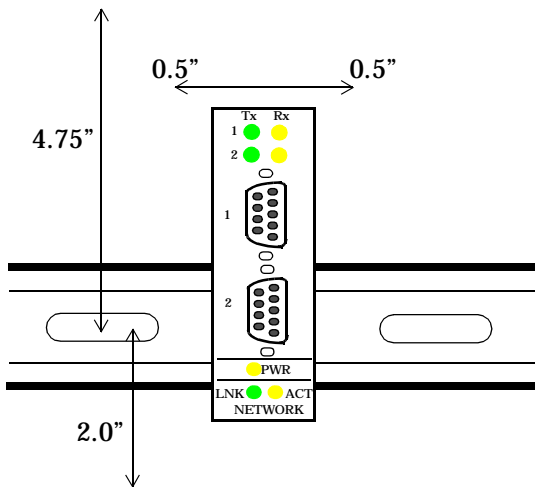

**Note:** For optimal operation, make sure that the device is mounted in a vertical orientation with a minimum of 0.5" space on either side and a minimum of 4.75" clearance from the center of the rail to any device or wire trough above the unit and a minimum of 2.0" below.

- Connect an Ethernet cable from the port labeled **Network** on the RocketPort Serial Hub *ia* to your server NIC card (10/100Base-T) or Ethernet hub.

**Note:** If connecting the RocketPort Serial Hub *ia* directly to a NIC, an **Ethernet crossover cable** is required. This is not supplied by Control.

- Wire the screw terminal so that you can connect the screw terminal to the optional 24VDC power adapter or directly to a 24VDC local power source.

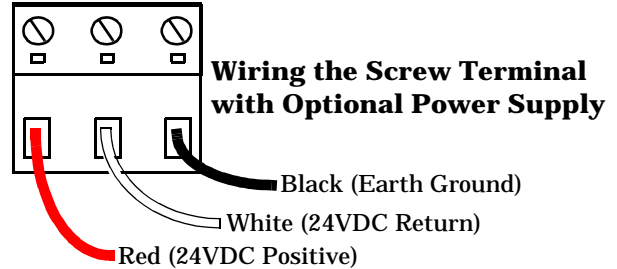

### Wiring the Screw Terminal for a Local Power Supply

Wire gauge:  
AWG 12-22

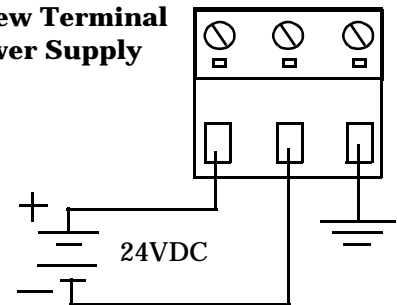

**Note:** When connecting and disconnecting the unit, make sure that you observe proper ESD techniques.

- Plug the screw terminal into the RPSH-ia.

**Note:** Make sure you align the plug properly. The scalloped edge of the screw terminal is the bottom and is closest to the text on the device.



**Caution**

The RocketPort Serial Hub *ia* driver's default port setting is RS-232. Make sure that you do not connect devices until the appropriate port interface type has been configured in the device driver.

- If necessary, connect the power cord to the power adapter and plug the power cord into a power source.

**Note:** You may need to select the appropriate AC power cable for your location.

## Verifying the Hardware Installation

Use the following information to verify that the hardware is working properly:

- The yellow PWR LED is flashing, indicating you have power and that the device driver has not been downloaded to the device.
- The green LNK LED is lit, indicating that you have a working Ethernet connection.
- The yellow ACT LED flashes, indicating Ethernet activity on the network.

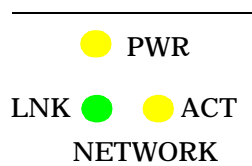

After the driver is installed and configured and the devices are connected, the yellow Rx LED shows that the data receiver is connected to another RS-232 device and the green Tx LED shows that the RS-232 data transmitter is on.

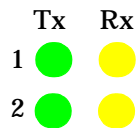

**Note:** These LEDs are not valid for RS-422 or RS-485 mode.

After verifying that the RocketPort Serial Hub *ia* is working correctly, you are ready to install the driver using the appropriate *Software Installation* documentation.

- [Linux](#)
- [Windows 95/98](#)
- [Windows NT](#)

**Note:** Do not use the Windows 95/98 or Windows NT driver in Windows 2000 systems.

After you install the driver and configure the serial ports, you can use the [Connecting Devices](#) discussion to connect your serial devices.

You may want to download the most recent driver and software installation document from the Comtrol web/ftp sites:

- <http://www.comtrol.com/coperate.htm>
- <ftp://ftp.comtrol.com/readme.htm>

## Adding a Unit to an Existing Installation

Use this procedure to add another RocketPort Serial Hub *ia* to an existing configuration.

1. Install the RocketPort Serial Hub *ia* to an Ethernet hub or NIC card using the [Connecting to the Network](#) discussion.
2. Power-up the new RocketPort Serial Hub *ia* and verify that the Power LED lights.
3. Configure the driver to support the new RocketPort Serial Hub *ia*, using the [Software Installation](#) documentation or driver readme file.
4. Configure serial ports to support the serial devices.

## Replacing Hardware

Follow this procedure, to replace a RocketPort Serial Hub *ia* with another RocketPort Serial Hub *ia* in an existing configuration.

1. Disconnect the power from the RocketPort Serial Hub *ia* to be removed from service.
2. Remove the old unit and attach a new or spare RocketPort Serial Hub *ia*.
3. Connect the new RocketPort Serial Hub *ia* to the network hub or server NIC card.
4. Connect the power source to the new RocketPort Serial Hub *ia* and verify that it passes the power on self-test.
5. Change the driver to reflect the MAC or IP address of the new RocketPort Serial Hub *ia*.
6. Configure any RS-422 or RS-485 ports to match the previous unit.
7. Transfer *all* cabling from the old RocketPort Serial Hub *ia* to the new RocketPort Serial Hub *ia*.  
No port reconfiguration is needed, providing you reconnect the serial devices as previously cabled.
8. *It is not necessary* to shut down and restart the server.

## Troubleshooting

If you are having trouble with a RocketPort Serial Hub *ia*, try the following:

**Note:** Most customer problems reported to Comtrol Technical Support are eventually traced to cabling or network problems.

- Verify that the unit is powered on and that the PWR LED is lit.  
**Note:** If the PWR LED is flashing, this indicates that the driver has not downloaded to the unit.
- Verify that you are using the [correct types of cables](#) in the correct places and that all cables are connected securely.
- Verify that the Ethernet hub and any other network devices between the server and RocketPort Serial Hub *ia* are powered up and operating.
- To isolate the unit from the network, use a ["crossover" ethernet cable](#) to connect the unit directly to the NIC card in the server.
- Verify that you are using the correct device driver. Device drivers for the *RocketPort Serial Hub* and the *RocketPort Serial Hub ia* are different.  
**Note:** The drivers used for the RPSH-*ia* device are the same drivers used for the RPSH-Si series. For drivers with a GUI, you will select the RPSH-Si 2-port configuration.
- Reboot the server.
- See the [Software Installation](#) documentation for information on operating system specific troubleshooting procedures.
- Verify that the MAC address in the driver matches the address on the RocketPort Serial Hub *ia*.

- If using IP addressing:
  - Verify that the IP address in the driver matches the unique reserved IP configured address assigned by the system administrator.
  - Verify that the server can ping the RocketPort Serial Hub *ia*. If the ping fails, there is an addressing or network problem.
- Remove and reinstall the driver.
- If you have a spare RocketPort Serial Hub *ia*, try replacing RocketPort Serial Hub *ia* units. See the [Replacing Hardware](#) discussion.
 

**Note:** *If this corrects the problem, the RocketPort Serial Hub *ia* you have removed from service may be defective or in need of repair.*
- If you are unable to resolve the problem, [contact Technical Support](#).

## Connecting Devices

Use the following discussion to connect asynchronous serial devices to the RocketPort Serial Hub *ia* ports.



**Caution**

*Make sure that you have configured the ports using the driver for the correct communications mode before connecting any devices. The default mode in the drivers is RS-232. There is a remote possibility that connecting a peripheral for the wrong mode could damage the peripheral.*

1. Install or reconfigure the driver using the [Software Installation](#) documentation or the driver readme file.
2. Connect your devices to Ports 1 or 2 for each RocketPort Serial Hub *ia* using the appropriate cable. You can build your own cables using the [Building Null-Modem Cables](#) or [Building Straight-Through Cables](#) discussions.

**Note:** *Use the hardware manufacturer's installation documentation if you need help with connector pinouts or cabling for the peripheral device.*

## Building an Ethernet Crossover Cable

If you are connecting from the 10/100Base-T connector on the RocketPort Serial Hub *ia* directly to the NIC card in the server, you need a crossover cable. Use the following information to build a cable or purchase a cable.

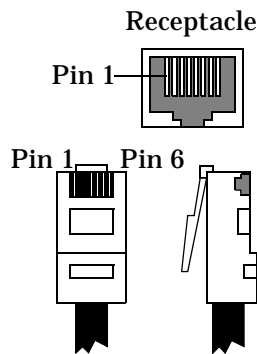

| Pin | Connects to Pin |
|-----|-----------------|
| 1   | 3               |
| 2   | 6               |
| 3   | 1               |
| 6   | 2               |

## DB9 Connector Pinouts

Use the following pinout information for the DB9 serial port connectors on the RocketPort Serial Hub *ia*.

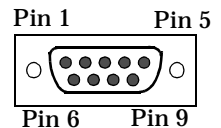

**DB9 Male**

| Pin | RS-232 | RS-422   | RS-485   |
|-----|--------|----------|----------|
| 1   | CD     | Not used | Not used |
| 2   | RxD    | RxD-     | Not used |
| 3   | TxD    | TxD-     | TRX-     |
| 4   | DTR    | Not used | Not used |
| 5   | GND    | Not used | Not used |
| 6   | DSR    | Not used | Not used |
| 7   | RTS    | TxD+     | TRX+     |
| 8   | CTS    | RxD+     | Not used |
| 9   | RI     | Not used | Not used |

## Building Null-Modem Cables

Use the following figure if you need to build a null-modem cable. A null-modem cable is required for connecting DTE devices.

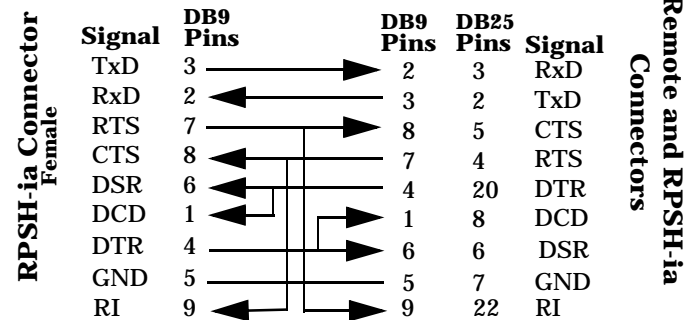

**Note:** *You may want to purchase or build a straight-through cable and purchase a null-modem adapter.*

## Building Straight-Through Cables

Use the following figure if you need to build a straight-through cable. Straight-through cables are used to connect DCE devices.

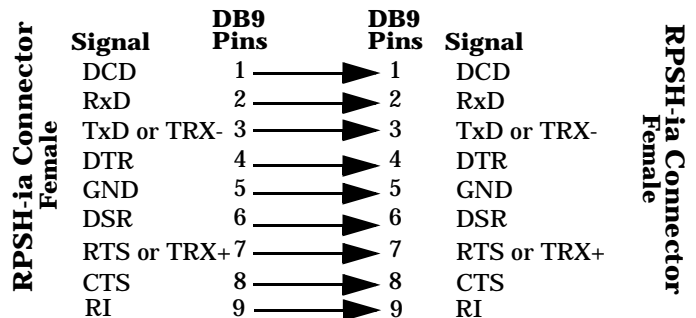

## Building Additional Loopback Plugs

Loopback connectors are DB9 female serial port plugs, with pins wired together as shown, that are used in conjunction with application software to test serial ports.

**Note:** Drivers for Windows 95/98 and Windows NT are bundled with the Test Terminal (WCOM32) program. Linux users can use MiniCom. See the [driver documentation](#) for your driver for information about using these applications.

The RocketPort Serial Hub *ia* is shipped with a single loopback plug (RS-232/422).

This information can help you build additional plugs or replace a missing loopback.

Wire the following pins together for an RS-232 loopback plug:

- Pins 1 to 4 to 6
- Pins 2 to 3
- Pins 7 to 8 to 9

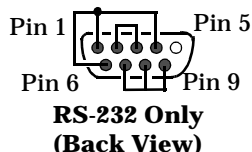

**Note:** The RS-232 loopback plug also works for RS-422.

Wire the following pins together for an RS-422 loopback plug:

- Pins 2 to 3
- Pins 7 to 8

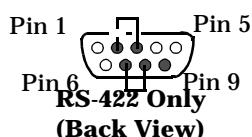

## Building an RS-485 Test Cable

You can use a straight-through cable [as illustrated previously](#), or build your own cable.

### RS-485 Loopback Cable for WCOM or MiniCom

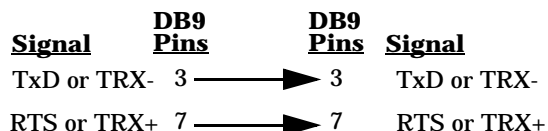

**Note:** The RS-485 loopback cable only requires Pins 3 and 7 to be connected.

## Hardware Specifications

This table illustrates environmental conditions.

| Environmental Conditions  | Value                    |
|---|--------------------------|
| Air temperature:<br>System on (operational)<br>System off (storage)           | 0 to 45°C<br>-20 to 85°C |
| Altitude  | 0 to 10,000 feet         |
| Heat output   | 9.6 BTU/Hr               |
| Humidity (non-condensing):<br>System on (operational)<br>System off (storage) | 8% to 80%<br>20% to 80%  |
| Mean Time between Failures (MTBF)   | 39.1 years               |

The following table lists electromagnetic compliance certifications.

| Electromagnetic Compliances   | Status |
|---|--------|
| Emission:<br>Canadian EMC requirements<br>CISPR-22/EN55022 Class A<br>FCC Part 15 Class A | Yes    |
| Immunity:<br>EN50082 (801-2 ESD, 801-3 RF,<br>and 801-4 FT)                               | Yes    |
| Safety:<br>EN60950<br>UL Listed   | Yes    |

The following table illustrates hardware specifications.

| Topic  | Hardware Specifications                                      |
|--|--|
| Current consumption                                      | 180 mA (24VDC)   |
| Input voltage  | 20 - 28VDC   |
| Power consumption  | 2.8 W  |
| Optional power supply:<br>Line frequency<br>Line voltage | 50 - 60 Hz<br>100 - 240VAC                                   |
| Ethernet host interface                                  | 10/100Base-T (10/100 Mbps - RJ45)                            |
| Hubs/server  | OS dependent, see the <a href="#">software documentation</a> |
| Number of ports/hub                                      | 2  |
| Baud rate/port (maximum)                                 | 115.2 Kbps   |
| Driver control:<br>Data bits<br>Parity<br>Stop bits      | 7 or 8<br>Odd, Even, None<br>1 or 2                          |
| Dimensions   | 4.1" x 3.3" x 1.0"   |
| Weight (hub, only)                                       | 10 oz  |

## Notices

### Radio Frequency Interference (RFI) (FCC 15.105)

---

This equipment has been tested and found to comply with the limits for Class A digital devices pursuant to Part 15 of the FCC Rules.

This equipment generates, uses, and can radiate radio frequency energy, and if not installed and used in accordance with the instruction manual, may cause harmful interference to radio communications. However, there is no guarantee that interference will not occur in a particular installation. If this equipment does cause harmful interference to radio or television reception, which can be determined by turning the equipment off and on, the user is encouraged to try and correct the interference by one or more of the following measures:

- Reorient or relocate the receiving antenna.
- Increase the separation between the equipment and the receiver.
- Connect the equipment into an outlet on a circuit different from that to which the receiver is connected.
- Consult the dealer or an experienced radio/TV technician for help.

### Labeling Requirements (FCC 15.19)

---

This equipment complies with part 15 of FCC rules. Operation is subject to the following two conditions:

- This device may not cause harmful interference.
- This device must accept any interference received, including interference that may cause undesired operation.

### Modifications (FCC 15.21)

---

Changes or modifications to this equipment not expressly approved by Control Corporation may void the user's authority to operate this equipment.

### Serial Cables (FCC 15.27)

---

This equipment is certified for Class A operation when used with unshielded cables.

### Underwriters Laboratory

---

This equipment is Underwriters Laboratory "UL" listed.

### Important Safety Information

---

To avoid contact with electrical current:

- Never install electrical wiring during an electrical storm.
- Never install the power plug in wet locations.
- Use a screwdriver and other tools with insulated handles.



## Technical Support

If you need technical support, contact Control using one of the following methods.

Corporate Headquarters:

- email: [support@comtrol.com](mailto:support@comtrol.com)
- FTP Site: <ftp://ftp.comtrol.com>
- Web Site: <http://www.comtrol.com>
- FAX: (763) 494-4199
- Phone: (763) 494-4100

Control Europe:

- email: [support@comtrol.co.uk](mailto:support@comtrol.co.uk)
- Web Site: <http://www.comtrol.co.uk>
- FAX: +44 (0) 1 869-323-211
- Phone: +44 (0) 1 869-323-220

Control has a staff of technical support representatives to help you.

### Trademark Notices

---

Control and RocketPort are trademarks of Control Corporation.

Windows, MS-DOS, and Microsoft are registered trademarks of Microsoft Corporation.

Other product names mentioned herein may be trademarks and/or registered trademarks of their respective owners.

First Edition, January 9, 2001  
Copyright © 2000. Control Corporation.  
All Rights Reserved.

Control Corporation makes no representations or warranties with regard to the contents of this document or to the suitability of the Control product for any particular purpose. Specifications subject to change without notice. Some software or features may not be available at the time of publication. Contact your reseller for current product information.

**2000169 Revision A**