

Five Port Expandable Smart Switch
Model 232XS5

Document ation Number 232XS5-1005

prt#4087-r2

*This product designed and manufactured in Ottawa, Illinois USA
of domestic and imported parts by*



International Headquarters

B&B Electronics Mfg. Co. Inc.

707 Dayton Road -- P.O. Box 1040 -- Ottawa, IL 61350 USA

Phone 815-433-5100 -- General Fax 815-433-5105

www.bb-elec.com

Orders e-mail: orders@bb-elec.com -- Fax 815-433-5104

Technical Support e-mail: support@bb.elec.com -- Fax 815-433-5104

European Headquarters

B&B Electronics

Westlink Commercial Park, Oranmore, Co. Galway, Ireland

Phone: +353 91-92444 -- Fax: +353 91-92445

www.bb-europe.com

© 1997 B&B Electronics -- Revised March 2005

© 2000 B&B Electronics . No part of this publication may be reproduced or transmitted in any form or by any means, electronic or mechanical, including photography, recording, or any information storage and retrieval system without written consent. Information in this manual is subject to change without notice, and does not represent a commitment on the part of B&B Electronics.

B&B Electronics shall not be liable for incidental or consequential damages resulting from the furnishing, performance, or use of this manual.

All brand names used in this manual are the registered trademarks of their respective owners. The use of trademarks or other designations in this publication is for reference purposes only and does not constitute an endorsement by the trademark holder.

TABLE OF CONTENTS

Chapter 1: INTRODUCTION	1
Checklist.....	2
Specifications	2
Chapter 2: SETUP.....	3
Port Configuration	4
Serial Data Configuration	6
RS-485 Support.....	6
Chapter 3: Smart Switch Operation	7
Programming the Second Character	8
Binary File Transfer	8
Smart Switch/Port Combiner Mode	9
Enhanced Timer Mode -- Timer Features	10
Expansion Mode.....	13
Chapter 4: SOFTWARE	15
Introduction	15
Installation	15
Setup	15
Default Values	16
Selecting Ports	16
Parameters.....	16
Appendix A: ASCII Character Codes	A-1
Appendix B: Cable Charts	B-1
Chart 1. IBM PC DB25 Connector to Master Port	B-1
Chart 2. IBM PC DB9 Connector to Master Port	B-1
Chart 3. Modem DB25 Connector to Master Port.....	B-2
Chart 4. IBM PC DB25 Connector to Ports A - E (DTE)	B-2
Chart 5. IBM PC DB25 Connector to Ports A - E (DCE).....	B-3
Chart 6. IBM PC DB9 Connector to Ports A - E (DTE)	B-3
Chart 7. IBM PC DB9 Connector to Ports A - E (DCE).....	B-4
Chart 8. IBM PC DB25 Connector to Ports A - E (DCE).....	B-4
Chart 9. IBM PC DB9 Connector to Ports A - E (DCE).....	B-5

Chapter 1: INTRODUCTION

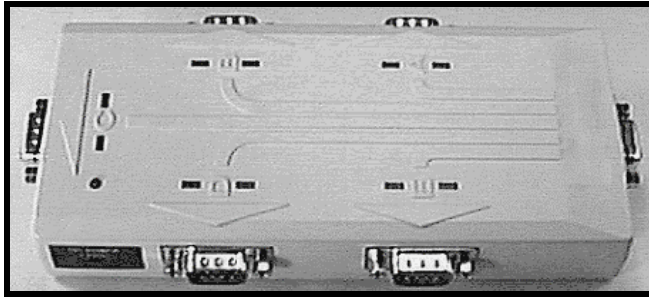

The RS-232 Five Port Expandable Smart Switch, Model 232XS5, allows one RS-232 host device to connect to as many as five RS-232 devices. The switch can be controlled in three different ways. The first way is referred to as **smart switch mode** or **code activated switch mode**. In this mode, the switch is controlled by sending a programmable preamble code to the "Master" port of the 232XS5. The second way the switch can be controlled is referred to as **port combiner mode**. In port combiner mode, a slave port can gain access to the master port by asserting a handshake line. If none of the slave ports have their handshake line asserted, the switch can be controlled using the preamble code. The third way the switch can be controlled is the **expander mode** in which up to four switches can be cascaded together to form up to 17 slave ports. The master port can be configured as a DTE or DCE port by an internal switch setting. If the master port is configured as a DTE port, the five slave ports will become DCE ports. The 232XS5 supports the following signals: TD, RD, RTS, CTS, DSR, DTR and DCD.

The 232XS5 has an enhanced timer mode which offers special timer features. The timer features can be used to prevent slave devices from receiving preamble commands, inadvertently switching from binary/graphic file transfers, and inactive slave devices from holding control of the master port.

The 232XS5 will work with baud rates from 1200 to 115.2K bps; 7 or 8 data bits; even, odd or no parity; and 1 or 2 stop bits (7,N,1 is not allowed).

NOTE: The data format and rates mentioned are used to switch the 232XS5. The communication between the devices can use any format or data rate.

There are five LED's on the 232XS5 to indicate which port is connected to the master port. The master port has a DB-9S female connector and the slave ports have DB-9P male connectors. The 232XS5 requires 12Vdc at 100ma. which is provided through a 2.5mm power jack.

Checklist

Examine the shipping carton and contents for physical damage. If damage is found, file a claim with the shipper immediately.

The following equipment should be in the shipping carton:

1. RS-232 Smart Switch
2. Instruction Manual
3. Software

If any of the items above are not in the shipping carton contact the shipper immediately.

Specifications

Model: 232XS5
Size: 3.0"w x 5.5"l x 1.0"h
Power: 12Vdc to 16Vdc @ 100ma

Chapter 2: SETUP

The 232XS5 is set up using an eight-position dipswitch and a three-position set of jumpers. This dipswitch is used to set the communication format, port configuration and expansion switch address. The jumpers are used to set the smart switch/port combiner mode, to enable/disable the enhanced features and to enable/disable Expander mode. To change the settings on the switch, remove the power from the unit, and remove the screws (4) from the bottom of the 232XS5. The dipswitch is located on the top of the PC board (side with LED's) and is labeled "SW1." The other dipswitch, labeled "SW2" is used to set the second character of the preamble. After the switches and jumpers have been set to match your requirements, you can put the unit back together. Table 1 shows the settings for dipswitch "SW1" and Table 2 shows the mode settings for "JP6" jumpers.

Table 1. Communication & Port Setup

Dipswitch SW1								Setting
1	2	3	4	5	6	7	8	
0	0	0	X	X	X	X	X	1200 Baud
1	0	0	X	X	X	X	X	2400 Baud
0	1	0	X	X	X	X	X	4800 Baud
1	1	0	X	X	X	X	X	9600 Baud *
0	0	1	X	X	X	X	X	19.2K Baud
1	0	1	X	X	X	X	X	38.4K Baud
0	1	1	X	X	X	X	X	57.6K Baud
1	1	1	X	X	X	X	X	115.2K Baud
X	X	X	0	X	X	X	X	8 Data Bits *
X	X	X	1	X	X	X	X	7 Data Bits
X	X	X	X	0	X	X	X	Parity Disabled *
X	X	X	X	1	X	X	X	Parity Enabled
X	X	X	X	X	0	0	X	Expansion Address A *
X	X	X	X	X	1	0	X	Expansion Address B
X	X	X	X	X	0	1	X	Expansion Address C
X	X	X	X	X	1	1	X	Expansion Address D
X	X	X	X	X	X	X	0	DCE master port *
X	X	X	X	X	X	X	1	DTE master port

0 = OFF 1 = ON X = DON'T CARE

* = FACTORY DEFAULT

Table 2. Mode Setup

Jumper JP6			Setting
A	B	C	
ON	X	X	Enhanced Disabled *
OFF	X	X	Enhanced Enabled
X	ON	X	Smart Switch *
X	OFF	ON	Expansion
X	X	ON	Combiner Disabled *
X	ON	OFF	Combiner Enabled

On = Jumper Installed Off = Jumper Removed X = DON'T CARE

* = FACTORY DEFAULT

Port Configuration

In order to determine the proper port configuration of the 232XS5, it is necessary to have a basic understanding of the terms DCE and DTE. RS-232 was designed, using DB-25 connectors, for connecting a DTE (Data Terminal Equipment) device to a DCE (Data Communication Equipment) device. Each device will have inputs on pins that correspond to outputs on the same pins of the other device. For example, a DTE device will transmit data out on pin 2 (on a DB-25) and a DCE device will receive data in on pin 2 (on a DB-25). IBM PCs and serial printers are DTE devices, modems are DCE devices.

Originally the RS-232 standard specified only a 25 pin D-sub connector. Since then, the use of a 9 pin D-Sub supporting only a portion of the original RS-232 signals has been used extensively, starting with the IBM PC and migrating into other peripherals. The pinouts for this 9 pin connector have since become the EIA/TIA 574 standard. This standard specifies a DTE device that transmits on pin 3 and receives on pin 2, with the DCE having the opposite configuration.

If an IBM PC compatible (DTE device) is going to be connected to the 232XS5 master port, the master port should be configured as a DCE port. If a modem (DCE device) is going to be connected to the master port, it should be configured as a DTE port.

The master port can be configured as a DCE port (data received on pin 3) or a DTE port (data received on pin 2) by setting dipswitch "SW1", position 8. To configure the master port as a DCE port, move dipswitch "SW1", position 8, to the "OFF" position. When the master port is configured as a DCE port, ports A, B, C, D & E will become DTE ports (Refer to Table 3). To configure the master port as a DTE port move dipswitch "SW1", position 8, to the "ON" position. When the master port is configured as a DTE port, ports A, B, C, D & E will become DCE ports (Refer to Table 4). Always power down the smart switch when changing switch settings.

Table 3. DCE MASTER PORT CHART

Master Port (DCE)		Signal Description	A,B,C,D & E Ports (DTE)	
Pin#	Direction		Pin#	Direction
3	Input	Transmit Data (TD)	3	Output
2	Output	Receive Data (RD)	2	Input
7	Input	Request to Send (RTS)	7	Output
8	Output	Clear to Send (CTS)	8	Input
4	Input	Data Terminal Ready (DTR)	4	Output
6	Output	Data Set Ready (DSR)	6	Input
1	Output	Data Carrier Detect (DCD)	1	Input
5	<----->	Signal Ground (SG)	5	<----->

Table 4. DTE MASTER PORT CHART

Master Port (DTE)		Signal Description	A,B,C,D & E Ports (DCE)	
Pin#	Direction		Pin#	Direction
3	Output	Transmit Data (TD)	3	Input
2	Input	Receive Data (RD)	2	Output
7	Output	Request to Send (RTS)	7	Input
8	Input	Clear to Send (CTS)	8	Output
4	Output	Data Terminal Ready (DTR)	4	Input
6	Input	Data Set Ready (DSR)	6	Output
1	Input	Data Carrier Detect (DCD)	1	Output
5	<----->	Signal Ground (SG)	5	<----->

The 232XS5 supports the following RS-232 signals: TD, RD, SG, RTS, CTS, DCD, DSR and DTR.

NOTE: All other lines are not connected.
The Smart Switch selects port A as the default port at power up.

Serial Data Configuration

In order for the host device that is connected to the master port to select any of the five ports, the Smart Switch must be set to match the host's communication format. Dipswitch "SW1" is used to select the communication format of the Smart Switch. Switch positions 1 through 3 select the baud rate. Switch position 4 selects 7 or 8 data bits. Switch position 5 determines if parity is enabled or disabled.

NOTE: A data format of 7 data bits, no parity and one stop is not allowed.

Switch position 8 selects the port configuration, see section titled "Port Configuration". Refer to Table 1. Always power down the smart switch when changing switch settings.

RS-485 Support

RS-485 support may be provided by adding a Model 485SD9TB RS-232 to RS-485 converter or other recommended device to the slave ports of the 232XS5.

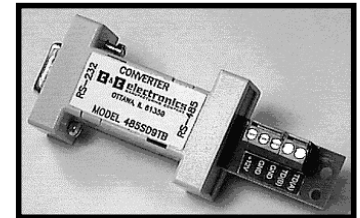

Port power of about 30 mA may be applied through the DTR line (Pin 4) of the slave ports with jumper JP1-JP5. Normally, the jumpers are set to allow DTR to pass from the master port. To enable port power on a slave port, move the jumper from the "OFF" to "ON" position on the corresponding JP jumper. To allow DTR to pass from the master port to the slave port, move jumper from "ON" to "OFF" on the corresponding JP jumper. DTR can only pass through when the port is selected and the jumper is set to the "OFF" position on the corresponding slave port JP jumper.

Jumper	Setting
JP1-5	
"OFF"	DTR passed *
"ON"	Port Power

Table 5. Port Power Jumpers
* = FACTORY DEFAULT

Chapter 3: Smart Switch Operation

Smart Switch mode is selected when jumper “JP6-B” is ON (installed). In Smart Switch mode, the 232XS5 is constantly looking for the three character preamble code by monitoring the data that is being received on the master port from the host device. The 232XS5 requires a three character preamble code to turn on and off a port. The first character must be the ASCII escape character (decimal 27). The second character is user programmable by setting dipswitch “SW2”. “SW2” comes from the factory programmed to the ASCII character STX (decimal 2). The third character should be the ASCII upper case letters "A", "B", "C", "D" or "E" (decimal 65, 66, 67, 68 or 69 respectively) to select those ports. To turn off the selected port the third character should be the ASCII EOT character (decimal 4). The ASCII characters and their equivalent decimal values are listed in Appendix A.

Example:

To turn on port B you would send the three ASCII characters:

ESC STX B

If you were writing a program in BASIC to control the Smart Switch you would form a string like this:

SWB\$ = CHR\$(27) + CHR\$(2) + "B"

You could then send SWB\$ to select port B. Similar strings could be used for turning on the other ports. To turn off the ports the string might look like this:

TOFF\$ = CHR\$(27) + CHR\$(2) + CHR\$(4)

When you are done with a port you can either select a new one directly or turn off the selected port and then turn on the next one. We recommend that you turn off the selected port before selecting the next one. The turn off command consists of three characters that are nonprinting (ESC STX EOT). If port A is selected and you send the command to select port B, all three characters (ESC STX B) will pass through the A port since it is still selected and the letter B will show up on your port A device. For information on preventing command codes from being received by slave devices, refer to the Enhance Mode section.

NOTE: There is no delay through the Smart Switch and the data is not buffered.

Programming the Second Character

The second character comes programmed as the ASCII STX character (decimal 2). You can change this to any 8-bit character you wish by reprogramming dipswitch “SW2”. “SW2” is an eight-position switch with each position equal to a certain weight. Refer to “Setup” for instructions on removing the cover to access “SW2”. Table 6 shows the weight chart for “SW2”.

Table 6. Programmable Character Setting

Dipswitch SW2*	WEIGHT
1	1
2	2
3	4
4	8
5	16
6	32
7	64
8	128

*Factory Default -- ASCII “STX” character (decimal 2), SW2 position 2 is only one ON.

If you wish to use the letter "U" as the second character, which has a decimal value of 85, you would turn on switches 1, 3, 5, and 7 (1 + 4 + 16 + 64 = 85). Caution should be used when selecting the second character, so that by itself, or with the ESC character in front of it, it is not a valid command to any of the devices on the port. For instance, on some printers ESC @ is the reset command. If you tried to use the @ symbol (decimal 64) for the second character you could reset your printer every time the preamble code was sent. Note also that if your communication configuration is set for 7 data bits you cannot use the eighth bit of SW2. For a list of the ASCII character codes and their decimal values, refer to Appendix A.

Binary File Transfer

A simple method of using the Smart Switch to transfer binary files without the concern of it accidentally disconnecting, is to set the file transfer at a baud rate different from the baud rate of the Smart Switch. When transferring files at a different baud rate, the Smart Switch will stay connected from the last preamble code.

Smart Switch/Port Combiner Mode

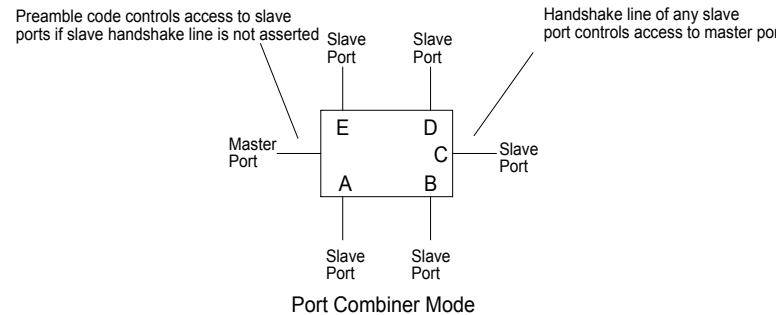

With the 232XS5 set up with a DTE master port, this mode allows Slave Ports A-E to select the master port using the RTS input line. It also still allows selection from the master port via the preamble code described in the Smart Switch Only Mode section. Jumper “JP6-C” must be OFF (removed) to be in port combiner mode. Port combiner mode is not accessible when the unit is set up as a port expander, so JP6-B must be ON (installed). When RTS goes high on any of the five slave ports, it will establish a connection from that port to the master port. This works on first-come-first-served basis. If multiple ports have their RTS lines high, the port that has been waiting the longest will be next to be connected to the master port. For example (initial conditions -- no slave ports with RTS lines asserted.), in chronological order, Port C asserts its RTS line, Port A asserts its RTS line, Port D asserts its RTS line and then Port C disasserts its RTS line. When Port C asserts its RTS line, a connection will be made between the master port and Port C. When Port C disasserts its RTS line, Port C will be disconnected and Port A will be connected to the master port. When Port A disasserts its RTS, Port A will be disconnected and Port D will be connected to the master port.

For example, port A is configured as a DTE port. In order to establish a connection to the master port, port A must set RTS high (assert). The 232XS5 would recognize this as a prompt for connection to the master port. The connection would be dropped as soon as RTS on port A is brought low. Ports B-E may raise RTS at any time to request a connection. However, if port A is connected to the master port, any data sent from the devices on ports B-E to the 232XS5 will be lost. The 232XS5 does not have any buffering.

NOTE: When a port is selected via the Master Port, the RTS lines will be ignored until the Master Port sends the turn off code. When the Master Port is selected by RTS, all preamble codes will be ignored. The port combiner function is not available with the Master Port configured as a DCE or in expansion mode.

A typical application would be to have RTS and CTS tied together on the master port. When RTS on port A is asserted, CTS on port A will be asserted when a connection is established. If a port is not connected to the master port, then CTS on that port will remain low. Therefore, a port can monitor the handshake line to determine if a connection has been established.

Enhanced Timer Mode -- Timer Features

The 232XS5 has an enhanced mode, which offers special timer features. The timer features can be used to prevent slave devices from receiving preamble commands, inadvertent switching from binary/graphic file transfers, and inactive slave devices from holding control of the master port. The timer has two different modes: an inactivity mode and an inadvertent switch mode. When in inactivity mode, the 232XS5 will monitor the data lines. If there is no activity for the specified time, the selected slave port will be disconnected from the master port. When in inadvertent switch mode, the 232XS5 will ignore switching commands for the specified period of time. After this time has expired, the selected slave port will be disconnected from the master port.

The timer functions are enabled via a jumper setting and through software commands. **Jumper JP6-A must be OFF (removed) for the 232XS5 to be in enhanced mode.** The software commands follow the same format as preamble codes used for switching. There are two commands that must be sent to the 232XS5 to set the timer functions: Set Timer Value and Set Timer Mode. These commands require an additional byte for data. The Set Timer Value command requires the third byte to be an ASCII “T” character. The data byte (fourth byte) must be a value between ASCII “0” and ASCII “9”. A value of “0” is used to disable the timer. The time set by the Set Timer Value command determines the length of time the 232XS5 will wait before disconnecting an inactive port, or the length of time it will ignore switching commands from the master. Refer to Table 7 for timer values. For example, sending the following string to the 232XS5 will set the timer value to 5 seconds (assuming programmable character is the factory default of 2).

SetTV\$ = CHR\$(27) + CHR\$(2) + "T" + "6"

The "T" tells the 232XS5 it is the set timer value command and the "6" indicates which timer value to use.

Table 7 - Timer Values

Data	Value
0	timer disabled
1	10ms
2	25ms
3	100ms
4	500ms
5	1 s
6	5 s
7	30 s
8	1 min.
9	5 min.

The Set Timer Mode command tells the 232XS5 whether the time set by the Set Timer Value command will be used to determine the time-out of an inactive port, or the length of time switching commands are ignored. The third byte of the Set Timer Mode command is an ASCII "M". If the data byte (fourth byte) is an ASCII "0", zero (default), the timer will be setup as an inactivity timer. For example, sending the following string to the 232XS5 will set up the timer as an inactivity timer (assuming programmable character is the factory default of 2).

SetTM\$ = CHR\$(27) + CHR\$(2) + "M" + "0"

The "M" tells the 232XS5 it is the set timer mode command and the "0" indicates to set up the timer as an inactivity timer. When the timer is configured as an inactivity timer, the 232XS5 will monitor the data lines (TD & RD) for data. If there is no activity for the specified timer value, the slave port that is connected to the master port will be disconnected. In smart switch mode, the inactivity timer can be used to prevent the preamble codes from being received by the slave devices. In port combiner mode, the inactivity timer can be used to prevent devices from tying up the master port. For example (port combiner mode), all the slave ports have their handshake lines asserted. The device on Port C has its handshake line asserted and is currently connected to the master port, but has not been transmitting or receiving data. When the inactivity timer expires, Port C will be disconnected and the next slave port will then be

connected to the master port (following the first-come-first-served rule). Port C will then be placed at the "end of the line".

If the data byte of the Set Timer Mode command is an ASCII "1", the timer will be setup to ignore switching commands. Sending the following string to the 232XS5 will set up the timer to ignore switching commands. (Assuming programmable character is the factory default of 2).

SetTM\$ = CHR\$(27) + CHR\$(2) + "M" + "1"

The "M" tells the 232XS5 it is the set timer mode command and the "1" indicates to set up the timer to ignore switching commands. When the timer is configured in this mode, the 232XS5 will not accept any switching commands ("A", "B", "C", "D", "E", or "EOT") for the specified timer value. After the timer has expired, the slave port that is connected to the master port will be disconnected. This feature is useful to prevent inadvertent switching during binary/graphic type file transfers. For example (smart switch mode), the timer is configured to ignore switching commands for 5 seconds. The select Port D command is sent to the 232XS5. Once Port D is connected a file of unknown data type (so file may or may not contain a switching command sequence) is to be transferred through the 232XS5. For a period of 5 seconds after Port D is connected, no switching commands will be accepted. As long as the file transfer takes less than 5 seconds, there is no chance the 232XS5 will inadvertently switch ports.

Table 8 - 232XS5 Smart Switch Mode Commands

Function	Command Characters				Comments
	1st	2nd	3rd	4th	
Select Port A	ESC	X*	"A"	NU**	Switching Command
Select Port B	ESC	X*	"B"	NU**	Switching Command
Select Port C	ESC	X*	"C"	NU**	Switching Command
Select Port D	ESC	X*	"D"	NU**	Switching Command
Select Port E	ESC	X*	"E"	NU**	Switching Command
Deselect Port	ESC	X*	EOT	NU**	Switching Command
Set Timer Value	ESC	X*	"T"	"0"- "9"	Enhanced Mode
Set Timer Mode	ESC	X*	"M"	"0", "1"	Enhanced Mode

*X represents the programmable character set by dipswitch SW2

**NU = Not Used

Expansion Mode

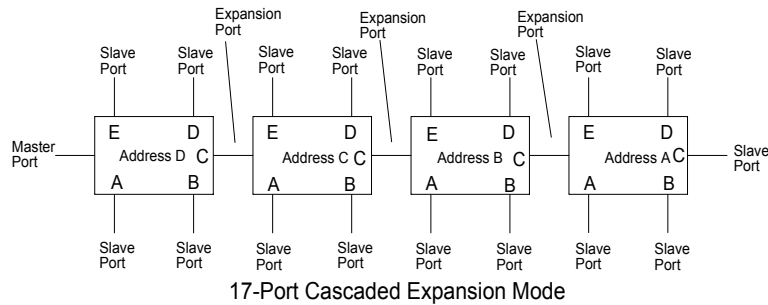

The number of serial ports on the 232XS5 can easily be expanded to a maximum of seventeen ports. Up to four 232XS5 units may be cascaded in expander mode. Each unit address adds four additional serial ports to the five on unit address "A". Port C is used as the expansion port that connects to the follow-on master-port for switch units addressed "B" thru "D". Expansion Switch unit address "A" is the last Switch in the chain.

Expander mode is selected when jumper "JP6-B" is OFF (removed.) In Expander mode, the 232XS5 is constantly looking for a four character preamble code by monitoring the data that is being received on the master port from the host device. The 232XS5 requires a four character preamble code to turn on and off a port. The first character must be the ASCII escape character (decimal 27). The second character is user programmable by setting dipswitch "SW2". "SW2" comes from the factory programmed to the ASCII character STX (decimal 2). The third character is the Expansion Switch Unit Address character "A" through "D". The fourth character should be the ASCII upper case letters "A", "B", "C", "D" or "E" (decimal 65, 66, 67, 68 or 69 respectively) to select those ports. To turn off the selected port the third character should be the ASCII EOT character (decimal 4). For instance, to turn on port B of Expansion Switch unit address C, you would send:

ESC STX C B

If you were writing a program in BASIC to control the Smart Switch you would form a string like this:

SWB\$ = CHR\$(27) + CHR\$(2) + "C" + "B"

You could then send SWB\$ to select port B of Expansion switch unit address "C". Similar strings could be used for turning on the other ports. To turn off the ports the string might look like this:

TOFF\$ = CHR\$(27) + CHR\$(2) + CHR\$(4)

When you are done with a port you can either select a new one directly or turn off the selected port and then turn on the next one. For information on preventing command codes from being received by slave devices, refer to the Enhanced Mode section.

Table 9 - 232XS5 Expander Mode Commands

Function	Command Characters				Comments
	1st	2nd	3rd	4th	
Select Port A	ESC	X*	"A"	"A"	Address A
Select Port B	ESC	X*	"A"	"B"	Address A
Select Port C	ESC	X*	"A"	"C"***	Address A
Select Port D	ESC	X*	"A"	"D"	Address A
Select Port E	ESC	X*	"A"	"E"	Address A
Select Port A	ESC	X*	"B"	"A"	Address B
Select Port B	ESC	X*	"B"	"B"	Address B
Select Port D	ESC	X*	"B"	"D"	Address B
Select Port E	ESC	X*	"B"	"E"	Address B
Select Port A	ESC	X*	"C"	"A"	Address C
Select Port B	ESC	X*	"C"	"B"	Address C
Select Port D	ESC	X*	"C"	"D"	Address C
Select Port E	ESC	X*	"C"	"E"	Address C
Select Port A	ESC	X*	"D"	"A"	Address D
Select Port B	ESC	X*	"D"	"B"	Address D
Select Port D	ESC	X*	"D"	"D"	Address D
Select Port E	ESC	X*	"D"	"E"	Address D
Deselect Port	ESC	X*	EOT	NU**	Switching Command
Set Timer Value	ESC	X*	"T"	"0"-9"	Enhanced Mode
Set Timer Mode	ESC	X*	"M"	"0", "1"	Enhanced Mode

* X represents the programmable character set by dipswitch SW2

** NU = Not Used

***Port C is used as the expansion port for unit addresses B thru D.

Chapter 4: SOFTWARE

Introduction

The Smart Switch software allows the user to change Smart Switch ports on three different modules (232XSS, 232XS5, PortMUX). The Smart Switch software is designed as diagnostic software for the above modules. It will allow you a Module by Module connection to the individual port.

Installation

The software for the Smart Switch is designed to be run in any Windows environment. To install it on your hard drive follow these steps:

Method One

- Install the software media.
- Select Settings from the Start Button and click on Control Panel.
- In the Control Panel Window, double click on the Add/Remove Programs.
- Click on the "Install" button.
- Follow the instructions of the setup program.

Method Two

- Install the software media.
- Select Programs from the Start Button and click on Windows Explorer.
- Click on the drive containing the software.
- Double click on the file "Setup.exe".
- Follow the instructions of the setup program.

The following file will be located on your hard drive:

- SS.EXE - The executable file for the Smart Switch.
- FILES.LST Contains a list and description of files installed on your hard drive.
- READ.ME Contains corrections and additions to the printed users manual.
- HISTORY.LST Contains a historic description of the product.

Setup

The Smart Switch program will prompt the user for the Module that is in use the first time that the software is run. After the proper Module (i.e. PortMUX, 232XS5, etc.) is selected then a window specific to that Module will appear and the user may personalize communication parameters as per their specific needs. Comport, Baud Rate, and Data Bits (Character Mode, and User Defined Character may also be set for 232XSS and 232XS5 Modules).

Should the user wish to change the Module choice to another there is a Module menu choice with the three support Module types (PortMUX, 232XSS, and 232XS5). After changing the Module the user will be prompted to restart the Smart Switch software to reset the connection.

Default Values

When you start Smart Switch software, the default values will be used. The default values are:

Description	Default Value
Port Address	COM 1
Baud Rate	9600
Data Bits	8 Data Bits
Second Character	2 = STX (CTRL B)

Selecting Ports

To select a port the user need only pick from the Menu-> Comport the comport to which the device is attached. The Smart Switch program supports comports 1 through 6. If the port exists but does not have a smart switch device attached, SS will not detect it. The SS software will only detect invalid/undefined comports.

Parameters

The Port Address is the address where the serial communications port is located. If this is unknown you can use the program PORTFIND.EXE which is located in the provided software. To use PORTFIND.EXE:

If you installed the software on your hard drive see the Installation section:

- Type **C:** and press the **ENTER** key.
- Type **CD\SSUTIL** and press the **ENTER** key.
- Type **PORTFIND** and press the **ENTER** key.

The result will be similar to the following:

```
PortFind V1.03 - © 1991 B&B Electronics - All Rights Reserved.
Slave 8259 present can't use shared IRQ2
COM1 at address 03F8h is set for IRQ4 and is a 8250A or 16450 type UART
COM2 at address 02F8h is set for IRQ3 and is a 8250A or 16450 type UART
LPT1 at address 0378h found
```

Some of the typical port addresses are as follows:

Port	Address
COM 1	03F8h
COM 2	02F8h
COM 3	03E8h
COM 4	02E8h

The Baud Rate is the speed at which communication takes place between the PC and the Smart Switch. It must be specified so that it is equal to SW1 – positions 1 – 3 on the Smart Switch.

The Number of Data Bits is the length of each character that gets sent from the PC to the Smart Switch. This value must be specified so that it is equal to SW1 – position 4 on the Smart Switch.

The Module must be set so that it is equal to the Smart Switch Module which you are using (i.e. PortMUX if you are using a PortMUX).

The User Defined Character must be set so that it is equal to SW2 on the Smart Switch.

Appendix A: ASCII Character Codes

DECIMAL to HEX to ASCII CONVERSION TABLE												
DEC	HEX	ASCII	KEY	DEC	HEX	ASCII	DEC	HEX	ASCII	DEC	HEX	ASCII
0	0	NUL	ctrl @	32	20	SP	64	40	@	96	60	`
1	1	SOH	ctrl A	33	21	!	65	41	A	97	61	a
2	2	STX	ctrl B	34	22	"	66	42	B	98	62	b
3	3	ETX	ctrl C	35	23	#	67	43	C	99	63	c
4	4	EOT	ctrl D	36	24	\$	68	44	D	100	64	d
5	5	ENQ	ctrl E	37	25	%	69	45	E	101	65	e
6	6	ACK	ctrl F	38	26	&	70	46	F	102	66	f
7	7	BEL	ctrl G	39	27	'	71	47	G	103	67	g
8	8	BS	ctrl H	40	28	(72	48	H	104	68	h
9	9	HT	ctrl I	41	29)	73	49	I	105	69	i
10	A	LF	ctrl J	42	2A	*	74	4A	J	106	6A	j
11	B	VT	ctrl K	43	2B	+	75	4B	K	107	6B	k
12	C	FF	ctrl L	44	2C	,	76	4C	L	108	6C	l
13	D	CR	ctrl M	45	2D	-	77	4D	M	109	6D	m
14	E	SO	ctrl N	46	2E	.	78	4E	N	110	6E	n
15	F	SI	ctrl O	47	2F	/	79	4F	O	111	6F	o
16	10	DLE	ctrl P	48	30	0	80	50	P	112	70	p
17	11	DC1	ctrl Q	49	31	1	81	51	Q	113	71	q
18	12	DC2	ctrl R	50	32	2	82	52	R	114	72	r
19	13	DC3	ctrl S	51	33	3	83	53	S	115	73	s
20	14	DC4	ctrl T	52	34	4	84	54	T	116	74	t
21	15	NAK	ctrl U	53	35	5	85	55	U	117	75	u
22	16	SYN	ctrl V	54	36	6	86	56	V	118	76	v
23	17	ETB	ctrl W	55	37	7	87	57	W	119	77	w
24	18	CAN	ctrl X	56	38	8	88	58	X	120	78	x
25	19	EM	ctrl Y	57	39	9	89	59	Y	121	79	y
26	1A	SUB	ctrl Z	58	3A	:	90	5A	Z	122	7A	z
27	1B	ESC	ctrl [59	3B	;	91	5B	[123	7B	{
28	1C	FS	ctrl \	60	3C	<	92	5C	\	124	7C	
29	1D	GS	ctrl]	61	3D	=	93	5D]	125	7D	}
30	1E	RS	ctrl ^	62	3E	>	94	5E	^	126	7E	~
31	1F	US	ctrl _	63	3F	?	95	5F	_	127	7F	DEL

Appendix B: Cable Charts

All charts will indicate if the Master Port of the 232XS5 should be configured as a DCE port or a DTE port. Refer to the Port Configuration section of the manual for information on Master Port configurations.

Chart 1. IBM PC DB25 Connector to Master Port

IBM PC Serial Port DB25 Connector	Signal Direction	232XS5 Master Port (DCE) DB9 Connector
2	----->	3
3	<-----	2
4	----->	7
5	<-----	8
6	<-----	6
7	<----->	5
8	<-----	1
20	----->	4*

* Pins are tied together inside the 232XS5, they are not connected to ports A, B, C, D, or E.

Chart 2. IBM PC DB9 Connector to Master Port

IBM PC Serial Port DB9 Connector	Signal Direction	232XS5 Master Port (DCE) DB9 Connector
1	<-----	1
2	<-----	2
3	----->	3
4	----->	4
5	<----->	5*
6	<-----	6
7	----->	7
8	<-----	8

* Pins are tied together inside the 232XS5, they are not connected to ports A, B, C, D, or E.

Chart 3. Modem DB25 Connector to Master Port

Async Modem Serial Port DB25 Connector	Signal Direction	232XS5 Master Port (DTE) DB9 Connector
2	<-----	3
3	----->	2
4	<-----	6
5	----->	4
7	<----->	5*
8	----->	8
20	<-----	7

* Pins are tied together inside the 232XS5, they are not connected to ports A, B, C, D, or E.

NOTE: When connecting a DTE device to ports A, B, C, D or E of the smart switch, refer to Charts 8 and 9.

Chart 4. IBM PC DB25 Connector to Ports A - E (DTE)

Master port configured as a DCE port.

IBM PC Serial Port DB25 Connector	Signal Direction	232XS5 Ports A - E (DTE) DB9 Connector
2	----->	2
3	<-----	3
4	----->	8
5	<-----	7
6	<-----	6
7	<----->	5
8	<-----	4*
20	----->	4*

* Pins are tied together inside the 232XS5, they are not connected to the master port.

Chart 5. IBM PC DB25 Connector to Ports A - E (DCE)

Master port configured as a DTE port.

IBM PC Serial Port DB25 Connector	Signal Direction	232XS5 Ports A - E (DCE) DB9 Connector
2	----->	3
3	<-----	2
4	----->	7
5	<-----	8
6	<-----	6
7	<----->	5
8	<-----	4*
20	----->	4*

* Pins are tied together inside the 232XS5, they are not connected to the master port.

Chart 6. IBM PC DB9 Connector to Ports A - E (DTE)

Master port configured as a DCE port.

IBM PC Serial Port DB9 Connector	Signal Direction	232XS5 Ports A - E (DTE) DB9 Connector
1	<-----	4*
2	<-----	3
3	----->	2
4	----->	6
5	<----->	5
6	<-----	4*
7	----->	8
8	<-----	7

* Pins are tied together inside the 232XS5, they are not connected to the master port.

Chart 7. IBM PC DB9 Connector to Ports A - E (DCE)

Master port configured as a DTE port.

IBM PC Serial Port DB9 Connector	Signal Direction	232XS5 Ports A - E (DCE) DB9 Connector
1	<-----	4*
2	<-----	2
3	----->	3
4	----->	4*
5	<----->	5
6	<-----	6
7	----->	7
8	<-----	8

* Pins are tied together inside the 232XS5, they are not connected to the master port.

Chart 8. IBM PC DB25 Connector to Ports A - E (DCE)

Master port configured as a DTE port with a modem connected (see Chart 3).

IBM PC Serial Port DB25 Connector	Signal Direction	232XS5 Ports A - E (DCE) DB9 Connector
2	----->	3
3	<-----	2
4	----->	6
5	<-----	4*
6	<-----	4*
7	<----->	5
8	<-----	8
20	----->	7

* Pins are tied together inside the 232XS5, they are not connected to the master port.

Chart 9. IBM PC DB9 Connector to Ports A - E (DCE)

Master port configured as a DTE port with a modem connected (see Chart 3).

IBM PC Serial Port DB9 Connector	Signal Direction	232XS5 Ports A - E (DCE) DB9 Connector
3	----->	3
2	<-----	2
7	----->	6
8	<-----	4*
6	<-----	4*
5	<----->	5
1	<-----	8
4	----->	7

* Pins are tied together inside the 232XS5, they are not connected to the master port.