

# *RS-232 Data Acquisition Module*

**Model 232SPDA**

**Documentation Number: 232SPDA-1005m**

*pn#3949-r2*

*This product Designed and Manufactured  
In Ottawa, Illinois USA  
of domestic and imported parts by*



## **International Headquarters**

B&B Electronics Mfg. Co. Inc.

707 Dayton Road

Ottawa, IL 61350 USA

**Phone** (815) 433-5100 -- **General Fax** (815) 433-5105

**Website:** [www.bb-elec.com](http://www.bb-elec.com)

**Sales e-mail:** [orders@bb-elec.com](mailto:orders@bb-elec.com) -- **Fax** (815) 433-5109

**Technical Support e-mail:** [support@bb.elec.com](mailto:support@bb.elec.com) -- **Fax** (815) 433-5104

## **European Headquarters**

B&B Electronics

Westlink Commercial Park

Oranmore, Co. Galway, Ireland

**Phone** +353 91-792444 -- **Fax** +353 91-792445

**Website:** [www.bb-europe.com](http://www.bb-europe.com)

**Sales e-mail:** [sales@bb-europe.com](mailto:sales@bb-europe.com)

**Technical Support e-mail:** [support@bb-europe.com](mailto:support@bb-europe.com)

Copyright © 1997 by B&B Electronics Manufacturing Company  
All rights reserved.

Revised February 2005

---

Documentation Number 232SPDA-1005 Manual

B&B Electronics Mfg Co Inc - 707 Dayton Rd - Ottawa IL 61350 - Ph 815-433-5100 - Fax 815-433-5104 - [www.bb-elec.com](http://www.bb-elec.com)

B&B Electronics - Westlink Comm Pk - Oranmore, Galway, Ireland - Ph +353 91-792444 - Fax +353 91-792445 - [www.bb-europe.com](http://www.bb-europe.com)

# Table of Contents

<b>CHAPTER 1- INTRODUCTION</b> .....	<b>1</b>		
232SPDA FEATURES .....	1		
PACKING LIST .....	2		
SOFTWARE INSTALLATION .....	2		
GETTING STARTED .....	3		
232SPDA SPECIFICATIONS .....	4		
<i>Analog to Digital Converter</i> .....	4		
<i>5 Volt Reference</i> .....	4		
<i>D/A Converter</i> .....	4		
<i>Digital Outputs</i> .....	4		
<i>Power Supply</i> .....	5		
<b>CHAPTER 2 - CONNECTIONS</b> .....	<b>7</b>		
A/D CONNECTIONS .....	7		
<i>A/D Inputs #0-6</i> .....	7		
<i>A/D Ref Input +</i> .....	7		
<i>A/D Ref Input -</i> .....	7		
<i>Analog Ground</i> .....	8		
<i>Typical Connections</i> .....	8		
D/A CONNECTIONS .....	9		
<i>D/A 0-3</i> .....	9		
<i>D/A References</i> .....	9		
<i>Typical Connections</i> .....	10		
DIGITAL I/O CONNECTIONS.....	10		
<i>Digital Inputs #0-1</i> .....	10		
<i>Digital Output</i> .....	11		
<i>Digital Ground</i> .....	11		
<i>Typical Connections</i> .....	11		
SERIAL PORT CONNECTIONS .....	11		
POWER SUPPLY CONNECTIONS .....	12		
<b>CHAPTER 3 - COMMANDS</b> .....	<b>13</b>		
SYNTAX .....	14		
READING A/D CHANNELS COMMAND .....	15		
READING DIGITAL I/O COMMAND .....	16		
SET DIGITAL OUTPUT COMMAND .....	17		
<b>CHAPTER 4 - A/D</b> .....	<b>19</b>		
SAMPLING RATE .....	19		
A/D INPUT RANGE .....	19		
REFERENCE INPUTS .....	19		
DATA RANGE .....	20		
CONVERTING DATA .....	20		
		<b>CHAPTER 5 - D/A</b> .....	<b>23</b>
		D/A OUTPUT RANGE.....	23
		D/A REFERENCE INPUTS .....	23
		DIGITAL INFORMATION FORMAT.....	24
		MULTIPLIER BIT .....	25
		CALIBRATING D/A REF .....	25
		CONVERTING DATA .....	26
		<b>CHAPTER 6 - SOFTWARE</b> .....	<b>29</b>
		READ A/D COMMAND.....	29
		READ DIGITAL I/O COMMAND .....	30
		SET DIGITAL OUTPUT STATES.....	31
		<b>CHAPTER 7: API FUNCTIONS</b> .....	<b>33</b>
		COMPILING AND LINKING .....	33
		<i>Borland/Turbo C++</i> .....	33
		<i>Borland/Turbo Pascal</i> .....	33
		<i>Microsoft® QuickBASIC</i> .....	34
		FUNCTION REFERENCE .....	34
		<i>deinitComPort</i> .....	34
		<i>initComPort</i> .....	35
		<i>spda_get_module_type</i> .....	36
		<i>spda_deinit</i> .....	36
		<i>spda_init</i> .....	37
		<i>spda_read_analog_inputs</i> .....	37
		<i>spda_read_digital_io</i> .....	38
		<i>spda_set_analog_outputs</i> .....	39
		<i>spda_set_digital_outputs</i> .....	40
		<i>spda_set_error_detection</i> .....	40
		<i>spda_startup</i> .....	41
		<b>APPENDIX A: DECIMAL TO HEX TO ASCII TABLE</b> .....	<b>43</b>
		<b>APPENDIX B: SCHEMATIC</b> .....	<b>45</b>
		<b>APPENDIX C: ANALOG INPUT IMPEDANCE</b> .....	<b>47</b>
		<b>APPENDIX D: ANALOG OUTPUT IMPEDANCE</b> .....	<b>51</b>

# Chapter 1- Introduction

## 232SPDA Features

The 232SPDA is a general purpose control module that connects to your computer's RS-232 serial port. The 232SPDA offers 7 channels of 12-bit A/D, 4 channels of 8-bit D/A, 2 digital inputs and 1 digital output. With these features, the module can be used to sense a wide range of external conditions and to control a variety of devices.

The 7 A/D channels allow you to measure voltages from 0 to 5 Volts. The 4 D/A channels allow you to output an analog voltage between 0V and 4.3V. The digital output is CMOS compatible. The 2 digital inputs are CMOS/TTL compatible. The A/D, D/A and digital I/O lines are available through a DB-25S (female) connector.

The 232SPDA connects to your computer's RS-232 serial port through a DB-25S connector. The unit automatically detects baud rates from 1200 to 9600. A data format of 8 data bits, 1 stop bit and no parity is used.

The 232SPDA requires 12VDC @ 35 milliamps (not including the power consumption of external devices).



Figure 1.1 - 232SPDA Unit

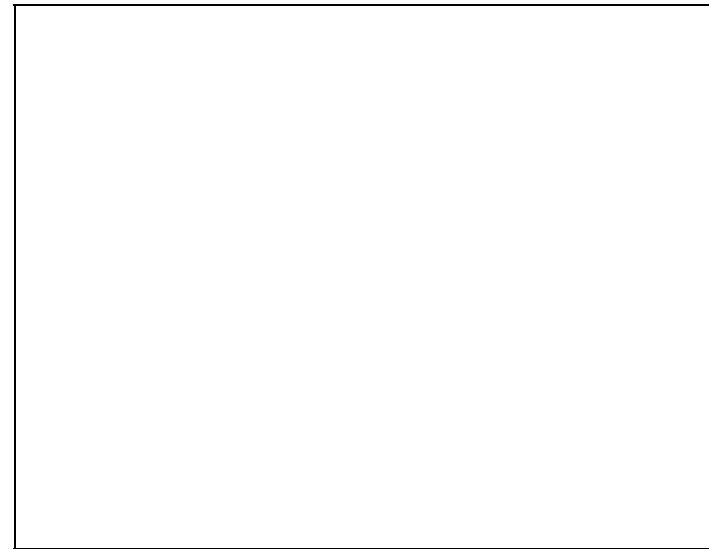

Figure 1.2 - Block Diagram of the 232SPDA

## Packing List

Examine the shipping carton and contents for physical damage. The following items should be in the shipping carton:

1. 232SPDA unit
2. Software
3. This instruction manual

If any of these items are damaged or missing contact B&B Electronics immediately.

## Software Installation

The 232SPDA comes with several demonstration programs. Your software media contains a file named "FILES.LST", which is a listing of the programs with descriptions.

## Getting Started

This section will provide a quick example using the 232SPDA and the demonstration program. If you experience any problems, refer to Chapter 2 for more precise information on connections. The demo program continually reads the A/D inputs and the digital I/O. The serial port is configured for 9600 baud, 8 data bits, no parity, 1 stop bit. The program supports standard addresses and IRQ's for COM1 and COM2.

Connect a 0 to 5VDC analog device to A/D input #0 or you can connect a variable resistor as shown in Figure 1.3. The variable resistor must be greater than 1k Ohms to limit the output current to 5 milliamps. Connect A/D Ref. Input + to +5VDC. Connect A/D Ref. Input - to analog ground (see Figure 1.3). Then connect the 232SPDA to a standard IBM serial port using a straight through cable or a standard DB-9 to DB-25 adapter cable. Once your connections have been made, run the demo program. Any change in A/D or digital lines on the 232SPDA will automatically be displayed on the screen.

To output an analog voltage, connect D/A 0 (I/O pin 22) to A/D 0 (I/O pin 8). Next, run the demo program. Follow the instructions on the screen to output an analog voltage. The demo program will display the voltage being outputted. With this connection A/D 0 is reading the voltage on D/A 0. A/D 0 and D/A 0 should be close to the same value. The D/A converter has 8-bit resolution while the A/D converter has 12-bit resolution, so some difference in the two values can be expected.

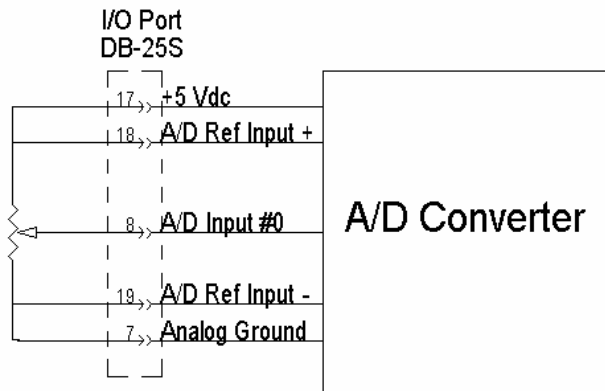

Figure 1.3 - A/D with Variable Resistor

## 232SPDA Specifications

### Analog to Digital Converter

Resolution:	12 bit
Channels:	7
Reference Range:	5.0 VDC max. (1.221 mV per bit) 2.5 VDC min. (0.610 mV per bit)
A/D Ref. Input -	0 VDC to 2.5 VDC
A/D Ref. Input +	2.5 VDC to 5.0 VDC
Input Voltage Range:	-0.3 VDC to 5.3 VDC
Total Unadjusted Error:	+/- 1.75 LSB max.

A/D input channels must be driven from a source impedance less than 1k $\Omega$ .

### 5 Volt Reference

Output Voltage:	4.975 to 5.025 VDC (5.0 VDC typ.)
Accuracy:	+/- 0.5 %
Output Current:	5 milliamps max.

### D/A Converter

Resolution:	8 bit
Channels:	4
Voltage Range:	0VDC to 4.3VDC
Reference Range:	-0.3VDC to 5.3VDC
Output Voltage Error:	+/-0.07V when multiplier bit = 0 +/-0.14V when multiplier bit = 1

D/A output channels must have a resistive load greater than or equal to 10 k $\Omega$  and a capacitive load less than or equal to 100 pF.

### Digital Inputs

Channels:	2
Voltage Range:	-30 VDC to 30 VDC
Low Voltage:	-30 VDC to 1.0 VDC
High Voltage:	2.0 VDC to 30 VDC
Leakage Current:	1 microamp max.

### Digital Outputs

Channels:	1
Low Voltage:	0.6 VDC @ 8.7 milliamps
High Voltage:	4.3 VDC @ -5.4 milliamps

**Power Supply**

Input Voltage: 12VDC to 16VDC @ 35 milliamps

**Communications**

Standard: RS-232 (unit is DCE)  
Baud Rate: 1200 to 9600 (automatic detection)  
Format: 8 data bits, 1 stop bit, no parity  
Connector: DB-25S (female)

## Chapter 2 - Connections

This chapter covers the connections required for the 232SPDA. There are five sets of connections: A/D converter, D/A connections, digital I/O, serial port and power supply. Do not make any connections to the 232SPDA until you have read this chapter. If you do not intend to use a section, it is still important to read each section.

### A/D Connections

The A/D connections are made on the I/O port, which is a DB-25S (female) connector. Table 2.1 shows the pinout of the I/O port. The next sections explain the functions and connections for the various analog signals.

#### A/D Inputs #0-6

These are the analog input channels. The analog data that is read from the 232SPDA is related to the voltage on these pins. Connect your devices to the analog input channels. Unused A/D inputs should be connected to analog ground.

#### A/D Ref Input +

The voltage connected to this pin determines the upper end of the input voltage range. For proper operation, this pin must be connected to a DC voltage between +2.5 and +5.0 Volts. The 232SPDA provides a 5.0V +/-0.5% reference. The 5V reference can be used if you require a 0 to 5VDC input range. If your application requires a better reference voltage or a different input range, you must supply the appropriate reference to this pin. This voltage **must be at least 2.5V greater than A/D Ref Input-**. Bypassing this pin with 0.01µF ceramic and 10µF tantalum capacitors to analog ground will help minimize noise.

#### A/D Ref Input -

The voltage connected to this pin determines the low end of the input voltage range. For proper operation, this pin must be connected to a DC voltage between 0 and +2.5 Volts. Typically, this is connected to your device's ground and analog ground, which is 0 Volts.

### Analog Ground

The pin should be connected to your analog devices ground. If ground (0V) is the low end of your input voltage range, A/D Ref Input - should be connected to this pin. To keep noise at a minimum **do not connect** analog ground and digital ground together. Unused A/D Inputs should be connected to analog ground.

### Typical Connections

Figure 2.1 shows the typical connections of the 232SPDA for a 0 to 5VDC input range.

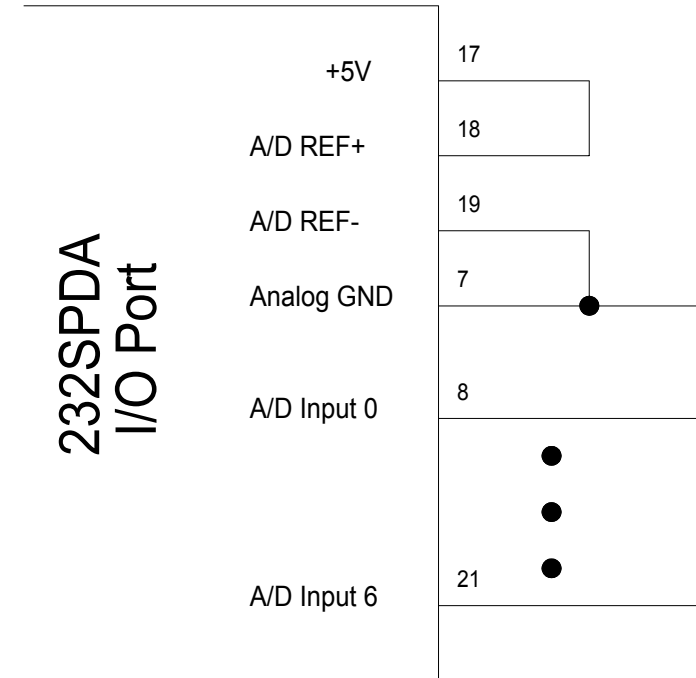

Figure 2.1 - Typical 0-5V A/D Connection

Table 2.1 - 232SPDA I/O Port Pinout

DB-25S Pin #	Function	DB-25S Pin #	Function
1	GND	14	D/A Ref. 1
2	+12VDC Output*	15	D/A Ref. 2
3	Digital Output	16	D/A Ref. 3
4	Digital Input #0	17	+5VDC Output
5	Digital Input #1	18	A/D Ref. Input +
6	Digital GND	19	A/D Ref. Input -
7	Analog GND	20	No connection
8	A/D Input #0	21	A/D Input #6
9	A/D Input #1	22	D/A Output 0
10	A/D Input #2	23	D/A Output 1
11	A/D Input #3	24	D/A Output 2
12	A/D Input #4	25	D/A Output 3
13	A/D Input #5		

\*Actual output is equal to power supply input minus 0.7VDC

## D/A Connections

The D/A connections are made on the I/O port, which is a DB-25S (female) connector. Table 2.1 shows the pinout of the I/O port. The following sections explain the functions and connections needed to output an analog voltage.

### D/A 0-3

These are the analog output channels. An 8-bit digital value is converted into an analog voltage and is placed on these pins. The analog voltages can range from 0V to 4.3V.

### D/A References

Each D/A channel outputs a voltage with respect to its reference. D/A Ref 0 is internally fixed at 5V. D/A Ref. 1-3 are determined by the voltage applied to pin #14-16. The voltages on pins 14-16 must be between 0V and 5V. Because of the electrical characteristics of the D/A converter, the maximum value used for D/A Ref 0-3 in the conversion equation will be near 3.75V even though 5V may be applied to Ref. 1-3 (pins 14-16). Therefore a 3.75V reference will produce the same output voltage that a 5V reference would.

## Typical Connections

Figure 2.2 shows the typical connections of the unit for a 0V to 4.3V analog voltage output range.

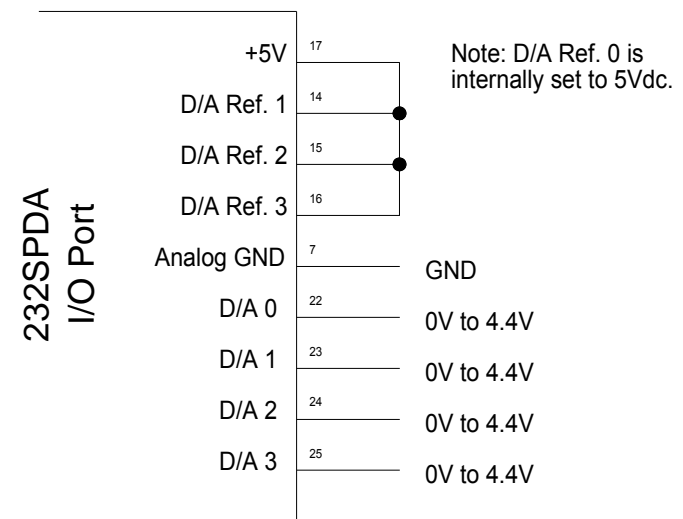

Figure 2.2 - Typical D/A Connections

## Digital I/O Connections

The digital I/O connections are made on the I/O port, which is a DB-25S (female) connector. Table 2.1 shows the pinout of the I/O port. The next sections explain the functions and connections for the various digital signals.

### Digital Inputs #0-1

The digital input lines are CMOS/TTL compatible and can handle voltages from -30VDC to +30VDC. If a digital input is from -30 VDC to 1.0VDC, the state will be read as a "0" (LOW). If a digital input is from 2.0VDC to 30VDC, the state will be read as a "1" (HIGH). Unused digital inputs should be connected to digital ground.

## Digital Output

The digital output line is CMOS compatible. A digital output that is set to a “0” (LOW) will output a voltage from 0 to 0.6VDC. A digital output that is set to a “1” (HIGH) will output a voltage from 4.3VDC to 5.0VDC. Refer to Chapter 1 - Specifications for more information. Unused digital output lines may be left open.

## Digital Ground

This pin should be connected to your digital device's ground. To keep noise at a minimum **do not connect** analog ground and digital ground together. Unused digital inputs should be connected to digital ground.

## Typical Connections

Figure 2.2 shows the typical connections of the 232SPDA for the Digital I/O lines.

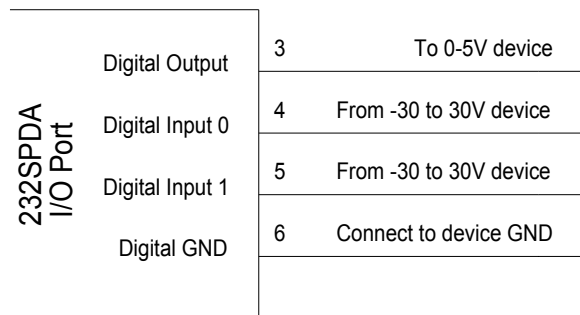

Figure 2.2 - Typical Digital I/O Connections

## Serial Port Connections

In order to communicate to the 232SPDA module, it must be connected to an RS-232 serial port. The unit automatically detects baud rates from 1200 to 9600. A data format of 8 data bits, 1 stop bit and no parity is used. The 232SPDA is configured as a DCE device (See Table 2.2). If your communications equipment is configured as a DTE device, such as a standard IBM PC serial port, the 232SPDA should be connected using a “straight through” DB-25 cable or a standard DB-9 to DB-25 cable adapter as shown in Table 2.3. If your communications equipment is configured as a DCE device, such as a modem, the 232SPDA should be connected using a “null modem” cable (See Table 2.4).

Table 2.2 - RS-232 Connector Pinout

DB-25S Pin #	Signal	232SPDA Function	Notes
2	Transmit Data (TD)	Input	Connection is required.
3	Receive Data (RD)	Output	Connection is required.
4	Request to Send (RTS)		Not used.
5	Clear to Send (CTS)		Not used.
6	Data Set Ready (DSR)		Not used.
7	Signal Ground (SG)		Connection is required.
8	Data Carrier Detect (DCD)		Not used.
20	Data Terminal Ready (DTR)		Not used.

Table 2.3 - 232SPDA To DTE Connections

232SPDA Pin #	Signal	DTE DB-25 Connection	DTE DB-9 Connection
2	Transmit Data (TD)	2	3
3	Receive Data (RD)	3	2
4	Request to Send (RTS)	4	7
5	Clear to Send (CTS)	5	8
6	Data Set Ready (DSR)	6	6
7	Signal Ground (SG)	7	5
8	Data Carrier Detect (DCD)	8	1
20	Data Terminal Ready (DTR)	20	4

Table 2.4 - 232SPDA To DCE Connections

232SPDA Pin #	Signal	DCE DB-25 Connection	DCE DB-9 Connection
2	Transmit Data (TD)	3	2
3	Receive Data (RD)	2	3
4	Request to Send (RTS)	5	8
5	Clear to Send (CTS)	4	7
6	Data Set Ready (DSR)	20	4
7	Signal Ground (SG)	7	5
8	Data Carrier Detect (DCD)	N/C	N/C
20	Data Terminal Ready (DTR)	6	6

## Power Supply Connections

The 232SPDA requires 12 to 16 VDC at 35 milliamps. Remember that the 35 milliamp requirement doesn't include the power consumption of any external devices. Therefore, any current that you source with the digital outputs and D/A outputs must be added to this value.

## Chapter 3 - Commands

There are only four commands required to control the 232SPDA: the read A/D command, read digital I/O command, output analog voltage command, and the set output states command. The command string consists of four bytes. The read A/D, output analog voltage, and digital I/O commands require one or two additional data bytes. See Table 3.1.

**Table 3.1 - 232SPDA Commands**

Function	Command	Response
Read A/D Channels	!ORA{#}	{ch#msb}{ch#lsb}{ch(#-1)msb}... {ch0msb}{ch0lsb}
Read Digital I/O	!ORD	{I/O states}
Output Analog Voltage	!OSV{#}{#}	no response
Set Output States	!OSO{#}	no response

Note: Each {...} represents one byte.

An extended set of commands that offers bit error detection can be used with the 232SPDA. With the extended commands, the “!” character is replaced with the “#” character. Also, the compliment of each data byte must follow that particular data byte. See Table 3.2.

**Table 3.2 - 232SPDA Extended Commands**

Function	Command	Response
Read A/D Channels	#0RA{#} ~{#}	{ch#msb}~{ch#msb}{ch#lsb} ~{ch#lsb}{ch(#-1)msb}~{ch(#-1)msb} ... {ch0msb}~{ch0msb}{ch0lsb} ~{ch0lsb}
Read Digital I/O	#0RD	{I/O states}~{I/O states}
Output Analog Voltage	#0SV{#} ~{#}{#}~{#}	no response
Set Output States	#0SO{#} ~{#}	no response

Note: Each ~{...} represents the compliment of one byte.

Before going into the specifics of each command, it is important to understand that a byte has a value from 0 to 255 and can be represented in decimal (0 to 255), hexadecimal (00 to FF), or by an ASCII character. The commands in Table 3.1 are shown in ASCII, for example: “!ORD”. The decimal and hexadecimal equivalents of some ASCII characters are shown in Table 3.2. Notice that the ASCII representation of the character “0” does not have a value of 0. Refer to Appendix A for more ASCII, decimal and hexadecimal equivalents.

**Table 3.2 - Equivalent Values**

ASCII	Decimal	Hexadecimal
!	33	21h
0	48	30h
A	65	41h
D	68	44h
O	79	4Fh
R	82	52h
S	83	53h
V	86	56h
NUL	0	0h
SOH	1	1h
STX	2	2h
ETX	3	3h
EOT	4	4h
ENQ	5	5h
ACK	6	6h
BEL	7	7h

### Syntax

As mentioned earlier, the command string consists of four bytes. The first byte is the start of message byte. The start of message byte is always the “!” character. The second byte is the address byte. This byte allows each unit to have a unique address (useful in RS-485 networks). Since the 232SPDA uses RS-232 communications, this byte is the ASCII “0” (zero) character and cannot be changed. The next two bytes are the command characters. These bytes are used to specify which command will be executed by the module. Some commands require a fifth and sixth byte, data bytes.

Table 3.3 - Read A/D Response

# of Channels Specified			Response	
decimal	Hex	ASCII	Channels Returned (order of response)	Bytes Returned
0	0	NUL	Channel 0	2
1	1	SOH	Channels 1,0	4
2	2	STX	Channels 2,1,0	6
3	3	ETX	Channels 3,2,...,0	8
4	4	EOT	Channels 4,3,...,0	10
5	5	ENQ	Channels 5,4,...,0	12
6	6	ACK	Channels 6,5,...,0	14

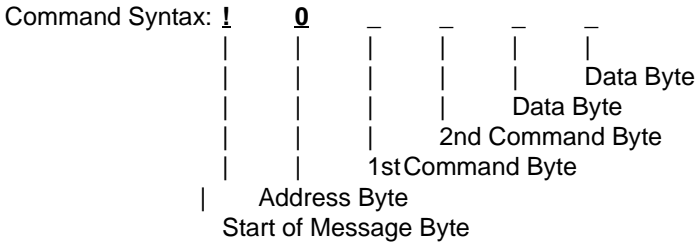

**Reading A/D Channels Command**

The Read A/D Channels command returns two bytes for each channel read. The two bytes represent the most significant byte (MSB) and least significant byte (LSB) of the reading. The MSB is received first, followed by the LSB. This command requires a data byte. The data byte is used to specify the number of the highest channel to be read. All channels less than this channel will be read as well. For example, if the data byte has a value of 6, then channels 0 to 6 will be read. The highest channel is read first.

Command Syntax  
**!ORA{#}**

Where “{#}” is a byte that specifies the number of the highest channel to be read. See Table 3.3

Response Syntax  
**{ch(#)MSB}{ch(#)LSB}{ch(#-1)MSB}...{ch0MSB}{ch0LSB}**

The most significant byte of the channel specified is received first. The least significant byte and the lower channels will follow in descending order. “{chxMSB}” and “{chxLSB}” represent the most and least significant bytes of the A/D conversion result.

**Reading Digital I/O Command**

The Read Digital I/O command returns a byte that represents the states of the 2 digital inputs and the digital output. Bit 3 corresponds to the state of the digital output. Bits 4-5 correspond to the states of digital inputs 0-1. If a bit is a 0 then the digital state of that digital I/O is LOW. If a bit is a 1 then the digital state of the I/O is HIGH. Refer to Table 3.4 and 3.5.

Command Syntax  
**!ORD**

Unit Response  
**{states}**

Where **{states}** is a byte in which Bit 3 corresponds to the current state of the Digital Output and Bits 4-5 correspond to the current states of Digital Inputs 0-1.

Table 3.4 - Read Digital I/O Response

Response Byte			Digital		
Bit 5	Bit 4	Bit 3	Input #1	Input #0	Output
0	0	0	LOW	LOW	LOW
0	0	1	LOW	LOW	HIGH
0	1	0	LOW	HIGH	LOW
0	1	1	LOW	HIGH	HIGH
1	0	0	HIGH	LOW	LOW
1	0	1	HIGH	LOW	HIGH
1	1	0	HIGH	HIGH	LOW
1	1	1	HIGH	HIGH	HIGH

### Set Digital Output Command

The Set Digital Output command is used to set the state of the digital output line. This command requires a data byte. The data byte is used to specify the output state. Bit 3 corresponds to the state of the digital output. If a bit is a 0 then the output will be set LOW. If a bit is a 1 then the output will be set HIGH. Note: This command ignores Bits 0-2 and 4-7 of the data byte.

#### Command Syntax

**!0SO{states}**

Where **{states}** is a byte in which Bit 3 corresponds to the outputs state of the Digital Output.

#### Unit Response

no response

## Chapter 4 - A/D

This chapter will deal with manipulating an A/D reading and cover some of the aspects that were not explained in the A/D connections chapter.

### Sampling Rate

The A/D converter has a conversion time around 10 microseconds, however the sampling rate is limited by the serial communications. The actual sampling rate for a single channel is around 120 samples per second (9600 baud). This rate drops to 37 samples per seconds when sampling all of the channels. When reading an A/D input, the 232SPDA takes four readings and returns the average (0.5 and greater are rounded up) of these readings. This averaging helps filter out noise.

### A/D Input Range

The A/D input range on the 232SPDA is from 0 to +5VDC. If it is possible for your device to output a voltage that doesn't fall in this range, steps must be taken to ensure that the voltage remains between 0 and +5VDC.

### Reference Inputs

The A/D reference inputs set the top and bottom of the data range. A/D Ref. Input - sets the bottom of the data range. A/D Ref. Input + sets the top of the data range. Since these inputs are directly related to the data range, it is important that a precision reference is used. The 232SPDA has a 5VDC +/- 0.5% reference available. The voltage on A/D Ref. Input + must be at least 2.5VDC greater than A/D Ref. Input -. The voltage difference between A/D Ref. Input + and A/D Ref. Input - is referred to as the Reference Range.

$$ReferenceRange = (A/DRefInput +) - (A/DRefInput -)$$

Typically A/D Ref. Input - is connected to Analog ground and A/D Ref. Input + is connected to +5VDC. Figure 2.1 in Chapter 2 shows the typical connections for a reference range of 0 to 5VDC.

### Data Range

The data range of the A/D converter is determined by A/D Ref. Input + and A/D Ref. Input -. A/D Ref. Input - sets the bottom of the data range. Any input voltage that is less than or equal to the A/D Ref. Input - will be read as a zero. A/D Ref. Input + sets the top of the data range. Any input voltage that is greater than or equal the A/D Ref. Input + will be read as a 4095 (0FFFH). The data range is as follows:

$$\begin{aligned} \text{Data Range} &= (\text{A/D Ref. Input -}) \text{ to } (\text{A/D Ref. Input +}) \\ \text{Data Range} &= 0 \text{ to } 4095 \\ \text{Data Range} &= 0 \text{ to } 0FFFH \end{aligned}$$

Figure 4.1 shows the Data Range and A/D Ref Inputs relationship.

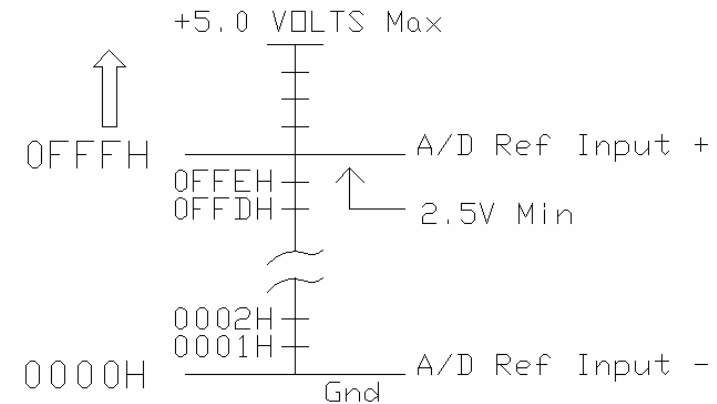

Figure 4.1 - A/D Converter Data Range

### Converting Data

The data read from the 232SPDA A/D converter is directly related to the A/D input channel and the reference range (discussed in previous sections). The 232SPDA has a 12-bit A/D converter. A 12-bit A/D has 4096 possible output values, 0 to 4095 (0 to 0FFFH). These 4096 output values are divided into equal steps over the reference range. The size of each step can be computed as follows:

$$StepSize = \frac{ReferenceRange}{4095}$$

The step size is also referred to as the resolution. Once the step size is known, all that is needed to determine the voltage of an A/D input is the number of steps. The data returned from the 232SPDA is the number of steps. The voltage at the A/D inputs can be calculated as follows:

$$\text{Voltage} = \text{NumOfSteps} \times \text{StepSize}$$

**Example 4.1** - Assume: A/D Ref. Input + = 5.0 VDC and A/D Ref.Input - = 0 VDC.

Therefore:

$$\text{Reference Range} = (\text{A/D Ref. Input } +) - (\text{A/D Ref. Input } -)$$

$$\text{Reference Range} = (5.0 \text{ VDC}) - (0 \text{ VDC})$$

$$\text{Reference Range} = 5.0 \text{ VDC}$$

$$\text{Step size} = (\text{Reference Range}) / 4095$$

$$\text{Step size} = (5.0 \text{ VDC}) / 4095$$

$$\text{Step size} = 1.221 \text{ millivolts}$$

Condition #1: A/D reading = 4095 (0FFFH)

$$\text{A/D voltage} = \text{reading} * \text{step size}$$

$$\text{A/D voltage} = 4095 * 1.221 \text{ millivolts}$$

$$\text{A/D voltage} = 5.0 \text{ Volts}$$

Condition #2: A/D reading = 0

$$\text{A/D voltage} = 0 * 1.221 \text{ millivolts}$$

$$\text{A/D voltage} = 0 \text{ Volts}$$

Condition #3: A/D reading = 675 (2A3H)

$$\text{A/D voltage} = 675 * 1.221 \text{ millivolts}$$

$$\text{A/D voltage} = 0.8242 \text{ Volts}$$

## Chapter 5 - D/A

This chapter will deal with converting a digital value into an analog voltage and some related aspects that were not explained in the D/A connections chapter and the Commands chapter.

### D/A Output Range

The four D/A channels have two different ranges. A multiplier bit is used to select between the two ranges. The first range includes voltages from 0V to about 3.75V. The value 3.75V will vary slightly depending on the module. The second voltage range includes voltages from 0V to 4.3V, but the resolution of the second range is not as good as the first range. A calibration section that explains how to determine the exact maximum value for Vref is included later in this chapter. The demo program uses the 0 to 3.75V range for voltages less than 3.75V and automatically switches to the larger range when voltages greater than 3.75V need to be produced. The multiplier bit is discussed in more detail later in this chapter.

### D/A Reference Inputs

The D/A References set the upper limit of the voltage ranges for each D/A channel. A voltage between 0V and 5V can be applied to D/A Ref. 1-3 (I/O pins 14-16). The reference for D/A 0 is internally fixed at 5V. Although up to 5V can be applied to pins 14-16, the maximum value for D/A Ref. 0-3 in the conversion equation is near 3.75V. As stated earlier the value 3.75V can vary slightly depending on the D/A converter. A calibration technique is covered later in this chapter. Table 5.1 compares values of D/A Ref. to actual voltages on I/O pins 14-16 and shows the maximum analog output voltage available in both voltage ranges.

Table 5.1 - D/A Ref., Actual Reference Voltage, and Maximum Output Voltage

Voltage Applied to pins 14-16	Value of D/A Ref. used in Conversion Equation	Maximum D/A Output Bit A5 = 0 x1	Maximum D/A Output Bit A5 = 1 x2
0V	0V	0V (FFh)	0V (FFh)
1V	1V	1V (FFh)	1.99V (FFh)
2V	2V	1.99V (FFh)	3.98V (FFh)
2.5V	2.5V	2.49V (FFh)	4.3V
3V	3V	2.99V (FFh)	4.3V
3.75V	3.75V	3.75V (FFh)	4.3V
4V	3.75V	3.75V (FFh)	4.3V
5V	3.75V	3.75V (FFh)	4.3V

1. Bit A5 is the Multiplier Bit which selects one of two ranges.
2. When Bit A5 is 1, the output is limited to 4.3V because of device limitations.
3. The values in the last column were calculated using the conversion equation, and corrected for device limitations.

### Digital Information Format

The information needed to select a D/A channel, the multiplier, and the output analog voltage is included in 2 bytes. Table 5.2 shows the bit assignments for these two bytes. Bits A7-A6 of byte1 select the D/A channel. Table 5.3 shows the channel selection based on the bit combinations. Bit A5 of byte1 multiplies the analog voltage by 1 or 2. Bits A4-A0 of the first byte and bits B7-B5 of byte2 represent the 8-bit analog voltage to be placed on the selected D/A channel. Bit A4 is the most significant bit and bit B5 is the least significant bit of the analog voltage. Bits B4-B0 of byte2 are ignored.

Table 5.2 - Bit Assignments

Byte 1								Byte 2									
Ch. select		8-bit voltage data								Ignored bits							
A	A	A	A	A	A	A	A	B	B	B	B	B	B	B	B	B	
7	6	5	4	3	2	1	0	7	6	5	4	3	2	1	0	0	

NOTE: A5 is the Multiplier Bit.

Table 5.3 - Channel Selection

A7	A6	D/A Channel
0	0	D/A Output 0
0	1	D/A Output 1
1	0	D/A Output 2
1	1	D/A Output 3

## Multiplier Bit

Now, the multiplier bit will be covered in more detail. Bit A5 is used as a multiplier. When A5 is 0, the output analog voltage is multiplied by 1. When A5 is 1, the output analog voltage is multiplied by 2. This can be seen more clearly in the conversion equation on the next page.

This multiplier is useful when analog output voltages must be greater than 3.75V. Setting bit A5 to 1 increases the maximum analog output voltage to 4.3V, but the resolution is decreased. The demo program is set up so that bit A5 is 0 when the output voltage is less than 3.75V, and bit A5 is set to 1 when the output voltage is greater than 3.75V. See Table 5.1 for the maximum analog output voltage for each range. Setting the multiplier bit to 1 to use the larger voltage range decreases resolution and increases error.

## Calibrating D/A Ref

As stated earlier, the maximum value for D/A Ref can vary slightly depending on the D/A converter. To calibrate for this error the following steps can be used:

1. Apply 5VDC to I/O pin 14, 15, and 16.
2. Using the demo software, output FFh (255 dec.) to D/A 0, 1, 2, and 3. The value 255 is used as the Digital Code.
3. Measure the voltages on I/O pins 22, 23, 24, and 25 with a digital multimeter or the A/D channels. These values are the analog voltages.
4. Using these values and A5=0, solve the Voltage Conversion Equation below for D/A Ref for each channel. These calculated values are the maximum values for D/A Ref. 0-3.
5. The value D/A Ref 0 is always used in the conversion equation for D/A 0.
6. If the voltage applied to pins 14-16 is greater than D/A Ref, then the calculated value of D/A Ref is used in the conversion equation. If the voltage applied to pins 14-16 is less than D/A Ref, then the voltage on pins 14-16 is used in the conversion equation. Refer to Table 5.1 for examples.

The maximum value for D/A Ref 0-3 is usually between 3.75V and 3.84V

## Converting Data

The four D/A channels take an 8-bit digital voltage and produce an analog voltage that is placed on I/O pins 22-25.

Data Range = 0 to 255 decimal (00H to FFH)

In this data range, 00H will produce an output analog voltage of 0V, and FFH will produce an output voltage equal to D/A Ref.(max = 3.75V) or 2 x D/A Ref.(max = 4.3V) of the selected channel.

The following equation is used to calculate the analog output voltage for each of the four D/A channels.

### Voltage Conversion Equation:

$$\text{AnalogVoltage} = \frac{D/ARef_{0..3} \times \text{DigitalCode} \times (1 + A5)}{256}$$

1. Digital Code is the digital representation of the voltage converted to a decimal value (0 to 255).
2. A5 is the multiplier bit. A5 can be either a 0 or a 1.
3. The number 256 represents the total number of steps in the data range.
4. D/A Ref 0-3 are the voltages applied to pins 14,15, or 16. The voltage applied to these pins can range between 0V and 5V. In the equation above, the maximum value used for D/A Ref 0-3 is 3.75V, even though the voltage applied at pins 14, 15, or 16 may be higher.

**Note: If D/A Ref. 0-3 is 3.75V and bit A5 is 1, the conversion equation implies that voltages greater than 4.3V can be obtained. This is not physically possible. The 232SPDA is limited to a maximum analog output of 4.3V because of the electrical characteristics of the D/A converter.**

Table 5.4 shows several conversion equation examples.

**Table 5.4 - Voltage Conversion Examples**

Digital Code								Analog Voltage
A 4	A 3	A 2	A 1	A 0	B 7	B 6	B 5	
0	0	0	0	0	0	0	0	GND
0	0	0	0	0	0	0	1	$(1/256)x(D/A \text{ Ref})x(1+A5)$
-	-	-	-	-	-	-	-	-
0	1	1	1	1	1	1	1	$(127/256)x(D/A \text{ Ref})x(1+A5)$
1	0	0	0	0	0	0	0	$(128/256)x(D/A \text{ Ref})x(1+A5)$
-	-	-	-	-	-	-	-	-
1	1	1	1	1	1	1	1	$(255/256)x(D/A \text{ Ref})x(1+A5)$

## Chapter 6 - Software

This chapter covers programming techniques such as constructing a command string, receiving data and manipulating data. The various steps and examples are shown in QuickBASIC. If you are programming in another language, these sections can be used as a guideline for programming the 232SPDA.

### Read A/D Command

The Read A/D Channels command returns two bytes for each channel read. The two bytes represent the most significant byte (MSB) and least significant byte (LSB) of the reading. The MSB is received first, followed by the LSB. This command requires a data byte. The data byte is used to specify the number of the highest channel to be read. All channels less than this channel will be read as well.

Step 1 - Constructing the command string:

**Command\$ = "IORA" + CHR\$(channel)**

The value of **channel** is equal to the highest channel to be read.

Step 2 - Transmitting the command string:

**Print #1, Command\$**

Step 3 - Receiving the data:

**MSB\$ = INPUT\$(1, #1)**

**LSB\$ = INPUT\$(1, #1)**

Step 4 - Manipulating the data:

**reading = (ASC(MSB\$) \* 256) + ASC(LSB\$)**

The value of **reading** is the result of the A/D conversion.

Step 5 - Repeat Steps 3 & 4 until each channel has been completed.

Example 5.1 - Read A/D channels 1 and 0

**channel = 1**

**Command\$ = "IORA" + CHR\$(channel)**

**Print #1, Command\$**

'Get the value of channel 1

**MSB\$ = INPUT\$(1, #1)**

**LSB\$ = INPUT\$(1, #1)**

**reading1 = (ASC(MSB\$) \* 256) + ASC(LSB\$)**

'Get the value of channel 0

**MSB\$ = INPUT\$(1, #1)**

**LSB\$ = INPUT\$(1, #1)**

**reading0 = (ASC(MSB\$) \* 256) + ASC(LSB\$)**

The value of **reading1** is the result of the A/D conversion on channel 1. The value of **reading0** is the result of the A/D conversion on channel 0.

### Read Digital I/O Command

The Read Digital I/O command returns a byte that represents the states of the 2 digital inputs and 1 digital output. Bit 3 corresponds to the state of digital output 1. Bits 4-5 correspond to the states of digital inputs 0-1. If a bit is a 0 then the digital state of that digital I/O is LOW. If a bit is a 1 then the digital state of the I/O is HIGH.

Step 1 - Constructing the command string:

**Command\$ = "IORD"**

Step 2 - Transmitting the command string:

**Print #1, Command\$**

Step 3 - Receiving the data:

**Reply\$ = INPUT\$(1, #1)**

Step 4 - Manipulating the data:

**states = ASC(Reply\$)**

Step 5 - Determining an I/O's status

**status = states AND mask**

By "ANDing" the value of **states** with the appropriate **mask** of an I/O line, the **status** of can be determined. If **status** is equal to zero then the I/O line is LOW. If **status** is not equal to zero then the I/O line is HIGH. Table 5.1 shows the **mask** values for each I/O.

Step 6 - Repeat Step 5 until the status of each I/O has been determined.

Table 5.1 - Digital I/O Mask Values

I/O Line	Mask Values	
	Hexadecimal	Decimal
Digital Output #0	8H	8
Digital Input #0	10H	6
Digital Input #1	20H	2

Example 5.2 - Determining the status of Digital Input #1

```
mask = &H10
Command$ = "!ORD"
Print #1, Command$
Reply$ = INPUT$(1, #1)
states = ASC(Reply$)
status = states AND mask
```

If **status** is equal to zero then Digital Input #1 is LOW. If **status** is not equal to zero then Digital Input #1 is HIGH.

### Set Digital Output States

The Set Digital Output command is used to set the state of the 1 digital output line. This command requires a data byte. The data byte is used to specify the output state. Bit 3 corresponds to the state of digital output 0. If a bit is a 0 then the output will be set LOW. If a bit is a 1 then the output will be set HIGH. Note: This command ignores Bits 0-2 and 4-7 of the data byte.

Step 1a - Constructing the command string:

```
Set Appropriate Outputs HIGH
states = states OR mask
```

By "ORing" the current **states** with the appropriate **mask** of a digital output (given in Table 5.1), the output's data bit will be set to a "1" (which will be set HIGH).

Step 1b - Set Appropriate Outputs LOW

```
states = states AND (NOT(mask))
```

By "ANDing" the current **states** with the complement of the appropriate **mask** of a digital output (given in Table 5.1), the output's data bit will be set to a "0" (which will be set LOW).

Step 1c - Construct the string

```
Command$ = "!OSO" + CHR$(states)
```

Step 2 - Transmitting the command string:

```
Print #1, Command$
```

Example 5.3 - Set Digital Output #0 HIGH.

' Set bit 3 of states to make Digital Output #0 HIGH

```
states = states OR 8
Command$ = "!OSO" + CHR$(states)
Print #1, Command$
```

Digital Output #0 will be set HIGH. Note that the variable **states** is assumed to be value from Example 5.2.

## Chapter 7: API Functions

The application program interface (API) is a set of functions that make it easy for a DOS-based program to interface with the 232SPDA module without knowing the low level details involved in communicating with each modules. These functions can be linked to programs written in Borland/Turbo C++, Borland/Turbo Pascal and Microsoft QuickBASIC v4.5.

### Compiling and Linking

#### Borland/Turbo C++

In order to use the API routines with Borland/Turbo Pascal, you must include the following lines at the beginning of your program:

```
#include "b485spda.h"
```

To compile and link a program with Borland C++ or Turbo C++, type the following at the DOS prompt:

```
bcc -ml yourprog.c b485spda.lib
```

#### Borland/Turbo Pascal

In order to use the API routines with Borland/Turbo Pascal, you must include the following lines at the beginning of your program:

```
{$M 4000, 0, 64000}  
uses b485spda;
```

The first line tells the compiler to leave some memory free for the serial communication routines that the API uses to communicate with the module. The second line includes the API routines in your program. To compile and link your program with Borland Pascal or Turbo Pascal, type the following at the DOS prompt:

```
tpc /B+ yourprog.pas
```

#### Microsoft® QuickBASIC

In order to use the API routines with QuickBASIC, you must include the following lines at the beginning of your program:

```
'$include: 'b485spda.bi'  
mem = SETMEM(-2000)
```

The first line includes the API routines in your program. The second line tells the compiler to leave some memory free for the serial communication routines that the API uses to communicate with the module. To compile and link a program with Microsoft® QuickBASIC, type the following at the DOS prompt:

```
bc yourprog.bas /D /O /T /C:512;
```

```
link yourprog.obj, yourprog.exe, nul.map,  
bcom45.lib+b485spda.lib /EX /NOE /NOD:brun45.lib;
```

### Function Reference

The API functions that must be called before any other API functions are used are `initComPort` and `spda_init`. In a pascal program, the function `spda_startup` must be called before the first time that `spda_init` is called. Before exiting the application, the functions, `spda_deinit` and `deinitComPort` must be called. The serial communication routines that the API functions use installs an interrupt service routine and exiting a program without calling `deinitComPort` may cause unpredictable results.

---

#### deinitComPort

**Purpose:** Initialize a serial communications port.

**Syntax:**

C:	<code>void pascal far deinitComPort (WORD hComDev);</code>
Pascal:	<code>procedure deinitComPort (hComDev : word);</code>
BASIC:	<code>sub deinitComPort (byval hComDev%);</code>

**Remarks:** *hComDev* is the handle to the serial communications port which is returned from the function, `initComPort`.

**Returns:** Nothing.

## initComPort

---

**Purpose:** Initialize a serial communications port.

**Syntax:** C:       WORD pascal far initComPort(WORD *addr*, BYTE *irq*, long *baud*);

      Pascal:   function initComPort(*addr* : word; *irq* : byte; *baud*: longint) : word;

      BASIC:    function initComPort%(byval *addr*%, byval *irq*%, byval *baud*%)

**Remarks:** *addr* is that serial port address. *irq* is the interrupt request number that the serial port uses. The table below shows the common port addresses and irq's.

Name	Address	IRQ
COM1	03F8h	4
COM2	02F8h	3
COM3	03E8h	4
COM4	02E8h	3

*baud* is the baud rate that will be used to communicate with the module. The valid values for *baud* are from 2 to 115200; however, the 232SPDA only allows baud rates between 1200 to 9600.

**Returns:** This function returns a handle to a serial communications port or -1 if the port could not be opened.

**See Also:** deinitComPort

## spda\_get\_module\_type

---

**Purpose:** Get the type of module.

**Syntax:** C:       int pascal far spda\_get\_module\_type(int *handle*);

      Pascal:   function spda\_get\_module\_type(*handle* : integer) : integer;

      BASIC:    function spdaGetModuleType%(byval *handle*%)

**Remarks:** *handle* is the handle to the module which is returned from the function, *spda\_init*.

**Returns:** This function returns the module type for the specified handle. 81h (129) is returned for the 232SPDA

## spda\_deinit

---

**Purpose:** Terminate communications with a module.

**Syntax:** C:       void pascal far spda\_deinit(int *handle*);

      Pascal:   procedure spda\_deinit(*handle* : integer);

      BASIC:    procedure spdaDeinit(byval *handle*%)

**Remarks:** *handle* is the handle to the module which is returned from the function, *spda\_init*.

**Returns:** Nothing.

**See Also:** spda\_init

## spda\_init

**Purpose:** Setup communications with a module.

**Syntax:** C: `int pascal far spda_init(WORD hComDev, int modType, BYTE modAddr);`

Pascal: `function spda_init(hComDev : word; modType : integer; modAddr : byte) : integer;`

BASIC: `function spdaInit%(byval hComDev%, byval modType%, byval modAddr%)`

**Remarks:** *hComDev* is the handle to a communications port which is returned by the function, *initComPort*. *modType* is the module type that we are using. The module type for the 232SPDA is 81h (129). *modAddr* is the module address. This is always 30h (48) for the 232SPDA module.

**Returns:** This function returns a handle that is used in other functions to communicate with this module.

**See Also:** `spda_deinit`

## spda\_read\_analog\_inputs

**Purpose:** Read the analog input channels of the module.

**Syntax:** C: `int pascal far spda_read_analog_inputs(WORD handle, WORD channels, WORD far *reply);`

Pascal: `function spda_read_analog_inputs(handle : word; channels : word; var reply : WordArray) : integer;`

BASIC: `function spdaReadAnalogInputs%(byval handle%, byval channels%, byval replyOfs%, byval replySeg%)`

**Remarks:** *handle* is the handle to the module which is returned from the function, *spda\_init*. *channels* is a bit mask for the channels to be read. Setting bit 0 of *channels* causes A/D channel 0 to be read, setting bit 1 causes A/D channel 1 to be read, etc.

Bit	7	6	5	4	3	2	1	0
Value	80h (128)	40h (64)	20h (32)	10h (16)	08h (8)	04h (4)	02h (2)	01h (1)
A/D	-	AD6	AD5	AD4	AD3	AD2	AD1	AD0

*reply* is a pointer to an array of seven 16-bit values where the analog values will be stored.

**Returns:** This function returns zero if an error occurred, otherwise it returns non-zero.

## spda\_read\_digital\_io

**Purpose:** Read the state of the digital I/O lines.

**Syntax:** C: `WORD pascal far spda_read_digital_io(int handle);`

Pascal: `function spda_read_digital_io(handle : integer) : word;`

BASIC: `function spdaReadDigitalIO%(byval handle%)`

**Remarks:** *handle* is the handle to the module which is returned from the function, *spda\_init*.

**Returns:** This function returns the digital I/O states. If a bit is set, then the corresponding I/O line is on. The table below describes the mapping of the bits that are returned.

Bit	7	6	5	4	3	2	1	0
Value	80h (128)	40h (64)	20h (32)	10h (16)	08h (8)	04h (4)	02h (2)	01h (1)
I/O	-	-	IN1	IN0	OUT0	-	-	-

**See Also:** `spda_set_digital_outputs`

## spda\_set\_analog\_outputs

**Purpose:** Set the analog output levels.

**Syntax:**

**C:** `void pascal far spda_set_analog_outputs(int handle, WORD channel, WORD value);`

**Pascal:** `procedure spda_set_analog_outputs(handle : integer; channel : word; value : word);`

**BASIC:** `sub spdaSetAnalogOutputs (byval handle%, byval channel%, byval value%)`

**Remarks:** *handle* is the handle to the module which is returned from the function, *spda\_init*. *channel* is the analog output channel to set. *value* is the digital value used to set the analog output. The output voltage for values less than 256 is given by:

$$volts = \frac{value \times vref_{channel}}{255}$$

and for values greater than 255, it is given by:

$$volts = \frac{2 \times \text{int}(value / 2) \times vref_{channel}}{255}$$

**Returns:** Nothing.

## spda\_set\_digital\_outputs

**Purpose:** Turn the digital output off or on.

**Syntax:**

**C:** `void pascal far spda_set_digital_outputs(int handle, BYTE state);`

**Pascal:** `procedure spda_set_digital_outputs(handle : integer; state : byte);`

**BASIC:** `sub spdaSetDigitalOutputs (byval handle%, byval state%)`

**Remarks:** *handle* is the handle to the module which is returned from the function, *spda\_init*. *state* is the new state of the output. If *state* is zero, then the output is turned off, otherwise it is turned on.

**Returns:** Nothing.

**See Also:** *spda\_read\_digital\_io*

## spda\_set\_error\_detection

**Purpose:** This function sets the communication mode that is used with the 232SPDA module. If error detection is on, extra bytes are sent as part of the command message and the reply to help identify communications problems.

**Syntax:**

**C:** `void pascal far spda_set_error_detection(int handle, BYTE state);`

**Pascal:** `procedure spda_set_error_detection(handle : integer; state : byte);`

**BASIC:** `sub spdaSetErrorDetection (byval handle%, byval state%)`

**Remarks:** *handle* is the handle to the module which is returned from the function, *spda\_init*. *state* is the state of the error detection. If *state* is zero, then error detection mode is off, otherwise it is on.

**Returns:** Nothing.

## **spda\_startup**

---

**Purpose:** This function must be called before the first time that `spda_init` is called in a pascal program.

**Syntax:** C: n/a

Pascal: `procedure spda_startup;`

BASIC: n/a

**Remarks:** This function initializes the internal variables of the API routines for a pascal program.

**Returns:** Nothing.

## Appendix A: Decimal to HEX to ASCII Table

DECIMAL to HEX to ASCII CONVERSION TABLE												
DEC	HEX	ASCII	KEY	DEC	HEX	ASCII	DEC	HEX	ASCII	DEC	HEX	ASCII
0	0	NUL	ctrl @	32	20	SP	64	40	@	96	60	`
1	1	SOH	ctrl A	33	21	!	65	41	A	97	61	a
2	2	STX	ctrl B	34	22	"	66	42	B	98	62	b
3	3	ETX	ctrl C	35	23	#	67	43	C	99	63	c
4	4	EOT	ctrl D	36	24	\$	68	44	D	100	64	d
5	5	ENQ	ctrl E	37	25	%	69	45	E	101	65	e
6	6	ACK	ctrl F	38	26	&	70	46	F	102	66	f
7	7	BEL	ctrl G	39	27	'	71	47	G	103	67	g
8	8	BS	ctrl H	40	28	(	72	48	H	104	68	h
9	9	HT	ctrl I	41	29	)	73	49	I	105	69	i
10	A	LF	ctrl J	42	2A	*	74	4A	J	106	6A	j
11	B	VT	ctrl K	43	2B	+	75	4B	K	107	6B	k
12	C	FF	ctrl L	44	2C	,	76	4C	L	108	6C	l
13	D	CR	ctrl M	45	2D	-	77	4D	M	109	6D	m
14	E	SO	ctrl N	46	2E	.	78	4E	N	110	6E	n
15	F	SI	ctrl O	47	2F	/	79	4F	O	111	6F	o
16	10	DLE	ctrl P	48	30	0	80	50	P	112	70	p
17	11	DC1	ctrl Q	49	31	1	81	51	Q	113	71	q
18	12	DC2	ctrl R	50	32	2	82	52	R	114	72	r
19	13	DC3	ctrl S	51	33	3	83	53	S	115	73	s
20	14	DC4	ctrl T	52	34	4	84	54	T	116	74	t
21	15	NAK	ctrl U	53	35	5	85	55	U	117	75	u
22	16	SYN	ctrl V	54	36	6	86	56	V	118	76	v
23	17	ETB	ctrl W	55	37	7	87	57	W	119	77	w
24	18	CAN	ctrl X	56	38	8	88	58	X	120	78	x
25	19	EM	ctrl Y	57	39	9	89	59	Y	121	79	y
26	1A	SUB	ctrl Z	58	3A	:	90	5A	Z	122	7A	z
27	1B	ESC	ctrl [	59	3B	;	91	5B	[	123	7B	{
28	1C	FS	ctrl \	60	3C	<	92	5C	\	124	7C	
29	1D	GS	ctrl ]	61	3D	=	93	5D	]	125	7D	}
30	1E	RS	ctrl ^	62	3E	>	94	5E	^	126	7E	~
31	1F	US	ctrl _	63	3F	?	95	5F	_	127	7F	DEL



## Appendix C: Analog Input Impedance

When interfacing with an A/D converter, it is important that the device you are connecting can drive the A/D input. To determine if your device can drive an A/D input, there are three factors you must consider:

- Output impedance of the device
- Input impedance of A/D
- A/D sampling time

The goal is to have the voltage at the A/D input settle to a voltage close to the output voltage of the device in a time frame that is less than the A/D sampling time (“close to” means a value significantly less than the resolution of the A/D). If the voltage does not settle fast enough, errors will occur in the reading, resulting in a loss of resolution.

The next section, titled “Simplified Analog Input Analysis,” contains information from Texas Instruments datasheet on the TLC1543. The TLC1543 is the A/D converter that is used on the 232SPDA. This section provides a simplified calculation which can be used to determine the maximum output impedance the device can have to settle the A/D input to a voltage within one half LSB.

For the 232SPDA:

$$t_c = 100\mu s$$

Using this information:

$$R_s \leq 170k\Omega$$

If the output impedance of your device is  $170k\Omega$ , you should figure an additional error of  $\frac{1}{2}$  LSB.

It should be pointed out that **this is a simplified analysis** and there other several other factors that must be considered (pin capacitance, noise immunity, etc.). The datasheet for the TLC2543 states that “The driving source impedance should be less than or equal to  $1k\Omega$ .” B&B Electronics recommends placing a voltage follower between the A/D input and any device with output source impedance greater than  $1k\Omega$ .

## Simplified Analog Input Analysis

Using the equivalent circuit in Figure C-1, the time required to charge the analog input capacitance from  $\emptyset$  to  $V_s$  within  $\frac{1}{2}$  LSB can be derived as follows:

The capacitance charging voltage is given by

$$V_c = V_s(1 - e^{-t_c/R_t C_i}) \quad (1)$$

where

$$R_t = R_s + r_i$$

The final voltage to  $\frac{1}{2}$  LSB is given by

$$V_c(1/2 \text{ LSB}) = V_s - (V / 8192) \quad (2)$$

Equating equation 1 to equation 2 and solving for time  $t_c$  gives

$$V_s - (V / 8192) = V_s(1 - e^{-t_c/R_t C_i}) \quad (3)$$

and

$$t_c(1/2 \text{ LSB}) = R_t \times C_i \times \ln(8192) \quad (4)$$

Therefore, with the values given the time for the analog input signal to settle is

$$t_c(1/2 \text{ LSB}) = (R_s + 1k\Omega) \times 60pF \times \ln(8192) \quad (5)$$

This time must be less than the converter sample time shown in the timing diagrams.

$V_i$  = Input Voltage at A $\emptyset$  - A1 $\emptyset$

$V_s$  = External Driving Source Voltage

$R_s$  = Source Resistance

$r_i$  = Input Resistance

$C_i$  = Equivalent Input Capacitance

\*Driving source requirements:

- Noise and distortion for the source must be equivalent to the resolution of the converter.
- $R_s$  must be real at the input frequency.

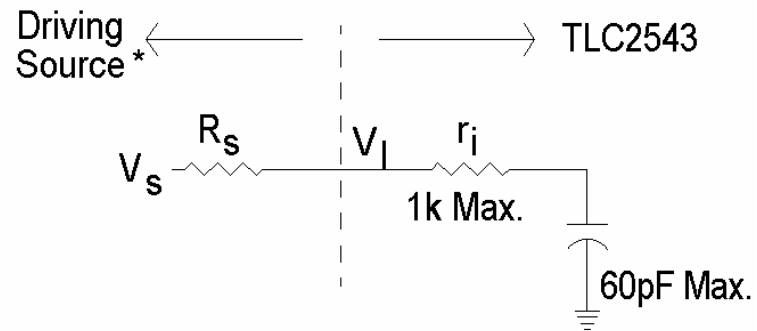

Figure C-1. Equivalent Input Circuit Including the Driving Source

## Appendix D: Analog Output Impedance

The load resistance  $R_L$  for the D/A output as shown in Figure D-1 must be greater than or equal to 10 k $\Omega$ . The load capacitance  $C_L$  must be less than or equal to 100 pF. If the device connected to the D/A output does not meet these requirements, B&B Electronics recommends placing a voltage follower similar to the one shown in Figure D-2 between the D/A output and any device with input impedance less than 10 k $\Omega$ . In this circuit  $R_L$  must be greater than or equal to 10 k $\Omega$ .

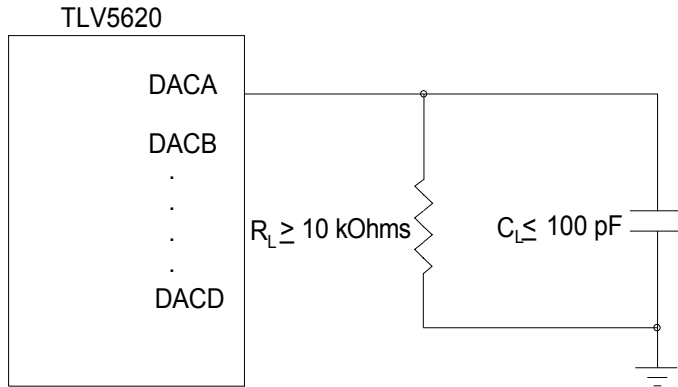

Figure D-1. Maximum D/A Load

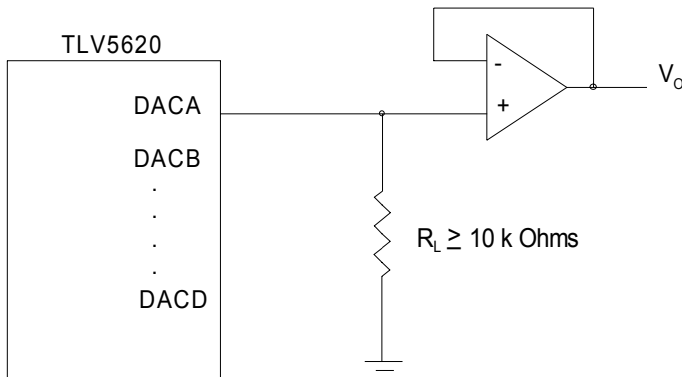

Figure D-2. Voltage Follower Circuit