

RS-232 Digital I/O Module

Model 232SDD16

Documentation Number 232SDD16-1005

pn#3604-r1

This product

Designed and Manufactured

In Ottawa, Illinois

USA

of domestic and imported parts by

B&B Electronics Mfg. Co. Inc.

707 Dayton Road -- P.O. Box 1040 -- Ottawa, IL 61350

PH (815) 433-5100 -- FAX (815) 433-5104

Internet:

<http://www.bb-elec.com>

sales@bb-elec.com

support@bb.elec.com

© 1995 B&B Electronics -- Revised February 2005

Table of Contents

Chapter 1 - Introduction	1
232SDD16 Features.....	1
Packing List.....	2
232SDD16 Specifications.....	3
I/O Lines.....	3
Digital Inputs.....	3
Digital Outputs.....	3
Power Supply.....	3
Communications.....	3
Size.....	3
Chapter 2 - Connections	5
Digital I/O Connections.....	5
Digital Inputs.....	5
Digital Outputs.....	5
Ground.....	5
Serial Port Connections.....	6
Power Supply Connections.....	8
Chapter 3 - Commands	9
Syntax.....	10
I/O Data Bytes.....	10
Read I/O Lines Command.....	12
Set Output Lines Command.....	12
Define I/O Lines Command.....	13
Set Power-up States Command.....	14
Read Configuration Command.....	14
Chapter 4 - I/O Interfacing	17
Digital Inputs.....	17
Digital Outputs.....	19

Chapter 5 - Software	21
Programming Techniques.....	21
Read I/O States Command.....	21
Read Configuration Command.....	22
Set Output States Command.....	24
Define I/O Lines Command.....	25
Set Power-up States Command.....	25
Demonstration Program.....	27
Hard Drive Installation.....	Error! Bookmark not defined.
Running Demonstration Program.....	27
APPENDIX A	A-1
ASCII Character Codes.....	A-1
APPENDIX B	B-1
Hexadecimal/Decimal Conversions.....	B-1
APPENDIX C	C-1
Interface Modules for SDD16 Models.....	C-1
DTB25.....	C-2
DBM16.....	C-4
DBM16 Interfacing.....	C-5
Inputs.....	C-5
Outputs.....	C-7
DBM16 Specifications.....	C-9
I/O Lines.....	C-9
Inputs.....	C-9
Outputs.....	C-9
Power Supply.....	C-9
Size.....	C-9
APPENDIX D	D-1
Adding Data Field Confirmation.....	D-1

Chapter 1- Introduction

232SDD16 Features

The 232SDD16 is a general purpose control module that is connected to your computer's RS-232 serial port. The 232SDD16 offers 16 discrete digital I/O lines. With these features, the module can be used to sense external ON/OFF conditions and to control a variety of devices.

The digital outputs are CMOS/TTL compatible. The digital inputs are CMOS/TTL compatible. The digital I/O lines are available through a DB-25S (female) connector.

The 232SDD16 connects to your computer's RS-232 serial port through a DB-25S connector. The unit automatically detects baud rates from 1200 to 9600. A data format of 8 data bits, 1 stop bit and no parity is used.

Configuration parameters are stored in non-volatile memory. The configuration parameters consists of I/O definitions, and output power-up states.

The unit may be powered by setting RTS and DTR high on the serial port. If the 232SDD16 cannot be powered using the handshake lines, it may be powered with +12Vdc through the 2.5mm jack or through the DB-25 I/O connector.

NOTE: When using an external supply, the supply should be connected only to specifically labeled power inputs (power jack, terminal block, etc.). Connecting an external power supply to the handshake lines may damage the unit. Contact technical support for more information on connecting an external power supply to the handshake lines.



Figure 1.1 - 232SDD16 Module

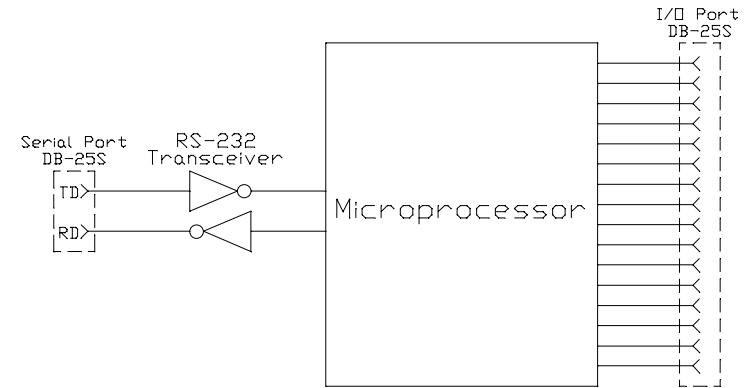

Figure 1.2 - Simplified Block Diagram

Packing List

Examine the shipping carton and contents for physical damage. The following items should be in the shipping carton:

1. 232SDD16 unit
2. Software
3. This instruction manual

If any of these items are damaged or missing contact B&B Electronics immediately.

232SDD16 Specifications

I/O Lines

Total: 16 (Factory default = inputs)

Digital Inputs

Voltage Range: 0 Vdc to 5 Vdc
Low Voltage: 1.0 Vdc max.
High Voltage: 2.0 Vdc min.
Leakage Current: 1 microamp max.

Digital Outputs

Low Voltage: 0.6 Vdc @ 8.3 milliamps (Sink)
High Voltage: 4.3 Vdc @ -3.1 milliamps (Source)

Power Supply

Input Voltage: 8 Vdc to 16 Vdc
External power: 35 milliamps* @ 12Vdc
Port power: 15 milliamps* (The RS-232 RTS
and DTR lines must be high to port
power unit.)

Doesn't include the power consumption of external devices.

Communications

Standard: RS-232 (unit is DCE)
Baud Rate: 1200 to 9600 (automatic detection)
Format: 8 data bits, 1 stop bit, no parity
Connector: DB25S (female)

Size 0.7" x 2.1" x 4.7"

Chapter 2 - Connections

This chapter will cover the connections required for the 232SDD16. There are three sets of connections: digital I/O, serial port, and power supply. Do not make any connections to the 232SDD16 until you have read this chapter.

Digital I/O Connections

Connections to the I/O lines are made through the DB25S (female) I/O port connector. Refer to Table 2.1. See Chapter 5 for I/O interfacing examples.

Digital Inputs

The digital input lines are CMOS/TTL compatible and can handle voltages from 0Vdc to +5Vdc.

Digital Outputs

The digital output lines have a maximum voltage of +5Vdc and are CMOS/TTL compatible.

Ground

The pin should be connected to your external digital devices ground.

Table 2.1 - 232SDD16 I/O Port Pinout

DB-25S Pin #	Function	DB-25S Pin #	Function
1	No connection	14	I/O #15
2	No connection	15	I/O #14
3	No connection	16	I/O #13
4	No connection	17	I/O #12
5	No connection	18	I/O #11
6	No connection	19	I/O #10
7	Ground	20	No connection
8	+12Vdc Input	21	I/O #9
9	I/O #0	22	I/O #8
10	I/O #1	23	I/O #7
11	I/O #2	24	I/O #6
12	I/O #3	25	I/O #5
13	I/O #4		

Serial Port Connections

In order to communicate to the 232SDD16 module it must be connected to an RS-232 serial port. The unit automatically detects baud rates from 1200 to 9600. A data format of 8 data bits, 1 stop bit and no parity is used. The 232SDD16 is configured as a DCE device (See Table 2.2). If your communications equipment is configured as a DTE device, such as a standard IBM PC serial port, the 232SDD16 should be connected using a "straight through" DB-25 cable or a standard DB-9 to DB-25 cable adapter as shown in Table 2.3. If your communications equipment is configured as a DCE device, such as a modem, the 232SDD16 should be connected using a "null modem" cable (See Table 2.4).

Table 2.2 - RS-232 Connector Pinout

DB-25S Pin #	Signal	Signal Direction at 232SDD16	Notes
2	Transmit Data (TD)	Input	Connection is required.
3	Receive Data (RD)	Output	Connection is required.
4	Request to Send (RTS)	Input	May be used to power unit if kept high.
7	Signal Ground (SG)		Connection is required.
20	Data Terminal Ready (DTR)	Input	May be used to power unit if kept high.

Table 2.3 - 232SDD16 To DTE Connections

232SDD1 6 Pin #	Signal	DTE DB- 25 Connection	DTE DB-9 Connection
2	Transmit Data (TD)	2	3
3	Receive Data (RD)	3	2
4	Request to Send (RTS)	4	7
7	Signal Ground (SG)	7	5
20	Data Terminal Ready (DTR)	20	4

Table 2.4 - 232SDD16 To DCE Connections

232SDD16 Pin #	Signal	DCE DB-25 Connection	DCE DB-9 Connection
2	Transmit Data (TD)	3	2
3	Receive Data (RD)	2	3
4	Request to Send (RTS)	5	8
7	Signal Ground (SG)	7	5
20	Data Terminal Ready (DTR)	6	6

Power Supply Connections

Power to the 232SDD16 can be supplied by the RS-232 serial port handshake lines (RTS, DTR) or by an external power supply through the 2.5mm power jack or from the I/O connector. Most serial ports can provide enough power to supply the 232SDD16's 15 milliamp requirement. If you plan to use this method to power the unit, your software must set the RS-232 RTS and DTR lines to the high state. An external power supply must be able to supply 8 to 16 Vdc at 35ma.

NOTE: Power requirements of the module does not include the power consumption of any external devices connected to the module. Therefore, any current that is sourced by the digital outputs must be added to this value and the current must not exceed the maximum output source current. Refer to the 232SDD16 Specification Section of this manual.

Chapter 3 - Commands

There are only two commands required to control the 232SDD16: set output lines, and read I/O lines. Three additional commands are used for configuring the module: define I/O lines, set power-up states, and read configuration. Command strings are from four to six bytes in length; the “!” character, the “0” (zero) character, two command characters, and one or two data bytes, if required. (See Table 3.1).

Table 3.1 - 232SDD16 Commands

Function	Command	Response
Set Output Lines	!0SO{I/O msb}{I/O lsb}	no response
Read I/O Lines	!0RD	{I/O msb}{I/O lsb}
Define I/O Lines	!0SD{I/O msb}{I/O lsb}	no response
Set Power-up States	!0SS{I/O msb}{I/O lsb}	no response
Read Configuration	!0RC	<i>I/O Definitions</i> {I/O msb}{I/O lsb} <i>Power-up States</i> {I/O msb}{I/O lsb}

Symbols: {...} represents one byte

<...> represents a numeric value

Before going into the specifics of each command, it is important to understand that a byte has a numeric value from 0 to 255. The byte's value can be represented in decimal (0 -255) format, hexadecimal (00 - FF) format, binary (00000000 - 11111111) format or as an ASCII character. The fixed bytes of each command will be represented as ASCII characters, for example: “!0RD”. Refer to Table 3.1. However, it is important to remember that an ASCII character has a numeric value. Example: the ASCII “0” (zero) does not have a value of zero but has a value of 48. The decimal and hexadecimal equivalents of some ASCII characters are shown in Table 3.2. Some commands require additional data bytes to complete the command. These data bytes may be represented in any of the formats listed above. Refer to Appendix A for more ASCII and decimal equivalents.

Table 3.2 - Equivalent Values

ASCII	Decimal	Hexadecimal
!	33	21h
0	48	30h
C	67	43h
D	68	44h
O	79	4Fh
R	82	52h
S	83	53h

Syntax

Command strings consists of four to six bytes. The first byte is the start of message byte. The start of message byte is always the ASCII “!” character. The second byte is the address byte. This byte allows each unit to have a unique address (useful in RS-485 networks). Since the 232SDD16 uses RS-232 communications, this byte is always the ASCII “0” character and can not be changed. The next two bytes are the command characters. These bytes are ASCII characters and used to specify which command will be executed by the module. Some commands require an argument field. This field contains the fifth and sixth data byte, a **Most Significant** and a **Least Significant** data byte respectively.

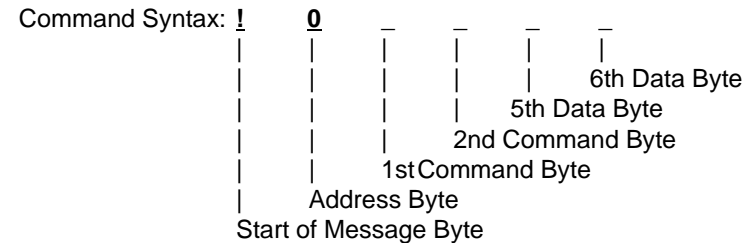

I/O Data Bytes

When constructing commands to manipulate outputs lines or when reading the state of the I/O lines it is necessary to know how to select and interpret the I/O data bytes. The sixteen I/O lines are represented by two data bytes. The Most Significant data byte represents I/O lines #15 through #8 and the Least Significant data byte represents I/O lines #7 through #0. The Most Significant byte is always sent and received first followed by the Least Significant byte.

A byte represents an eight-bit binary number (11111111), therefore each byte can represent eight I/O lines. Each bit is assigned a bit position and a weight (value). Refer to Table 3.3.

Table 3.3 - Bit Assignments for I/O Lines

MOST SIGNIFICANT I/O BYTE								
I/O Line #	15	14	13	12	11	10	9	8
Bit Position	7	6	5	4	3	2	1	0
Hex Weight	80	40	20	10	8	4	2	1
Dec. Weight	128	64	32	16	8	4	2	1

LEAST SIGNIFICANT I/O BYTE								
I/O Line #	7	6	5	4	3	2	1	0
Bit Position	7	6	5	4	3	2	1	0
Hex Weight	80	40	20	10	8	4	2	1
Dec. Weight	128	64	32	16	8	4	2	1

To set an output to a HIGH state the corresponding bit position must be set to a "1". Conversely to set an output LOW the corresponding bit position must be set to a "0". When reading I/O lines, any bit set to a "0" indicates the corresponding I/O line is in the LOW state and any bit set to a "1" indicates the corresponding I/O line is in the HIGH state.

Example 3.1 - To set outputs 15, 8, 1, and 0 to a HIGH state, and all other outputs to a LOW state (shown in bold face) -

	MS Byte	LS Byte
Shown in binary -	1000001	0000011
Shown in decimal -	129	3
	(128+1)	(2+1)
Shown in hexadecimal -	81	3
	(80h+1h)	(2h+1h)

Example 3.2 - Reply from Read I/O command (shown in bold face) -

	MS Byte	LS Byte
Shown in binary -	11001000	01010010
Shown in decimal -	200	82
	(128+64+8)	(64+16+2)
Shown in hexadecimal -	C8	52
	(80h+40h+8h)	(40h+10h+2h)

I/O lines #15, 14, 11, 6, 4, 1 are HIGH. All other I/O lines are LOW.

Read I/O Lines Command

The Read I/O Lines command returns two data bytes that reflect the state of the I/O lines. The first data byte contains the most significant I/O lines (15 - 8). The second data byte contains the least significant I/O lines (7 - 0). If a bit is a "0" then the state of that I/O line is LOW. If a bit is a "1" then the state of that I/O line is HIGH.

Command: !0RD

Argument: none

Response: the state of the 16 I/O lines in two 8 bit bytes (shown in bold face)

ASCII Example: !0RD**ÈR**

Dec. Example: !0RD<**200**><**82**>

Hex. Example: !0RD<**C8**><**52**>

Bin. Example: !0RD<**11001000**><**01010010**>

Description: the first byte indicates that I/O lines #15, 14, & 11 are HIGH and I/O lines # 13, 12, 10, 9, & 8 are LOW; the second byte indicates that I/O lines # 6, 4, & 1 are HIGH and I/O lines # 7, 5, 3, 2, & 0 are LOW.

Set Output Lines Command

The Set Output Lines command is used to set the states of the output lines. This command requires two data bytes. These data bytes specify the output state of each output line. The first data byte represents the most significant I/O lines (15 - 8). The second data byte represents the least significant I/O lines (7 - 0). If a bit position is set to a "0" then the state of that output line will be set LOW. If a bit position is set to a "1" then the state of that output line will be set HIGH.

NOTE: Refer to the "Define I/O Lines" command to define an I/O line as an output.

Command: !OSO
Argument: {I/O msb}{I/O lsb}
Response: none
ASCII Example: !OSOUA
Dec. Example: !OSO<85><65>
Hex. Example: !OSO <55><41>
Bin. Example: !OSO<01010101><01000001>
Description: the first byte sets output lines #14, 12, 10, & 8 HIGH and output lines #15, 13, 11, & 9 LOW; the second byte sets output lines #6, & 0 HIGH and output lines # 7, 5, 4, 3, 2, & 1 LOW. Note: If any of these lines are defined as inputs the bit settings are ignored.

Define I/O Lines Command

The Define I/O Lines command is used to define each of the 16 I/O lines as either an input or an output. This command requires two data bytes. Each data byte defines eight I/O lines. The first data byte defines the eight most significant I/O lines (15 - 8). The second data byte defines the eight least significant digital I/O lines (7 - 0). If a bit position is set to a "0" then the I/O line will be defined as an input. If a bit position set to a "1" then the I/O line will be defined as an output.

Command: !OSD
Argument: {I/O msb}{I/O lsb}
Response: none
ASCII Example: !OSDUA
Dec. Example: !OSD<85><65>
Hex. Example: !OSD<55><41>
Bin. Example: !OSD<01010101><01000001>
Description: the first byte define I/O lines #14, 12, 10, & 8 as outputs and I/O lines #15, 13, 11, & 9 as inputs; the second byte define I/O lines #6, & 0 as outputs and I/O lines #7, 5, 4, 3, 2, & 1 as inputs.

Set Power-up States Command

The Set Power-up States command is used to set the states of output lines when the module's power is recycled. This command requires two data bytes. These data bytes specify the output state of each output line. The first data byte represents the eight most significant I/O lines (15 - 8). The second data byte represents the eight least significant I/O lines (7 - 0). If a bit position is set to a "0" then the state of that output line will be set LOW. If a bit position is set to a "1" then the state of that output line will be set HIGH.

Command: !OSS
Argument: {I/O msb}{I/O lsb}
Response: none
ASCII Example: !OSSÛ@
Dec. Example: !OSS<219><64>
Hex. Example: !OSS<DB><40>
Bin. Example: !OSS<11011011><10000000>
Description: the first byte sets output lines #15, 14, 12, 11, 9, & 8 HIGH and output lines #13, & 10 LOW at power-up; the second byte sets output line #7 HIGH and output lines #6, 5, 4, 3, 2, 1, & 0 LOW at power-up. Note: If any of these lines are defined as inputs the bit settings are ignored.

Read Configuration Command

The Read Configuration command returns the module's I/O definitions and the outputs power-up state. Four data bytes are returned. The first two data bytes contain the definition of the eight most significant I/O lines (15 - 8) and the eight least significant I/O lines (7 - 0) respectively. If a bit position is set to a "0" the I/O line is defined as an input, if set to a "1" the I/O line is defined as an output. The second two data bytes contain the power-up states of the most significant output lines (15 - 8) and the least significant output lines (7 - 0) respectively. If a bit position is set to a "0" the power-up state of the output will be LOW, if set to a "1" the output will be HIGH.

Command: !0RC

Argument: none

Response: definition of the sixteen I/O lines in two 8 bit bytes, and the power-up states in two 8 bit bytes. (shown in bold face)

ASCII Example: !0RC**UAP**@

Dec. Example: !0RC<**85**><**65**><**80**><**64**>

Hex. Example: !0RC<**55**><**41**><**50**><**40**>

Bin. Example: !0RC<**01010101**><**01000001**><**01010000**><**01000000**>

Description: the first byte (MSB of I/O definitions) - I/O lines #14, 12, 10, & 8 are outputs and I/O lines #15, 13, 11, & 9 are inputs; the second byte (LSB of I/O definitions) - I/O lines #6, & 0 are outputs and I/O lines #7, 5, 4, 3, 2, & 1 are inputs; the third byte (MSB of output power-up states) - output lines #14, & 12 HIGH and output lines #10, & 8 LOW at power-up; the fourth byte (LSB of output power-up states) - output line #6 HIGH and output line #0 LOW at power-up.

Chapter 4 - I/O Interfacing

This chapter will explain "HIGH" and "LOW" states and show some general examples of how to interface to the I/O lines. Caution must be taken not to exceed 232SDD16 specifications listed in Chapter 1 when interfacing to external devices. Failure to stay within these specifications could result in damage to the unit and will void warranty.

Digital Inputs

As stated earlier, digital input lines are CMOS/TTL compatible and can only handle voltages from 0Vdc to +5Vdc.

Digital inputs are used to sense a HIGH or a LOW state. This can be accomplished via switch closures, contact closures, or a solid state digital signal. When an I/O line, defined as an input, senses a voltage level above +2.0Vdc it will be considered "HIGH" and its input state will be read as a "1". Conversely, when an input senses a voltage level below +1.0Vdc it will be considered "LOW" and its input state will be read as a "0".

Inputs can also be used to sense AC voltages by using mechanical or solid state relays. Solid state relays are available from many manufacturers.

Figures 4.1 - 4.4 show examples of some typical input interfaces.

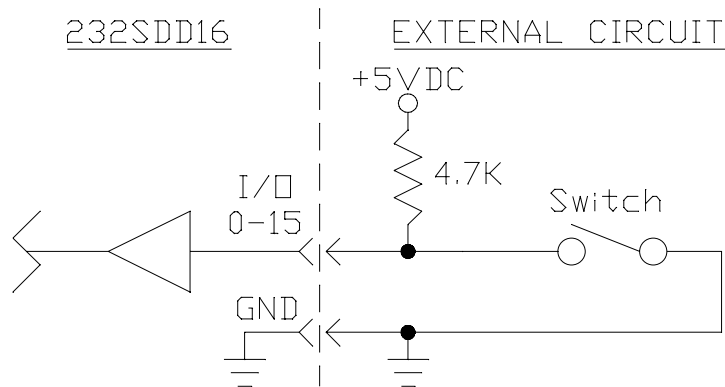

Figure 4.1 - Switch Input

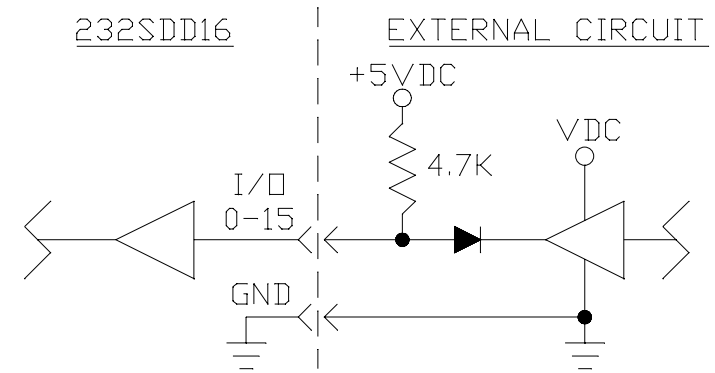

Figure 4.2 - Solid State Input

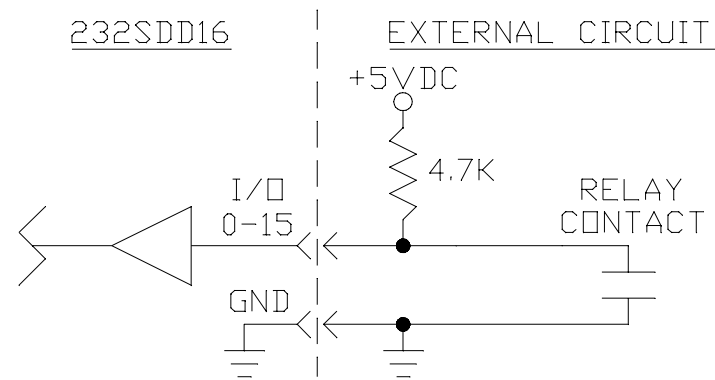

Figure 4.3 - Isolated Mechanical Input

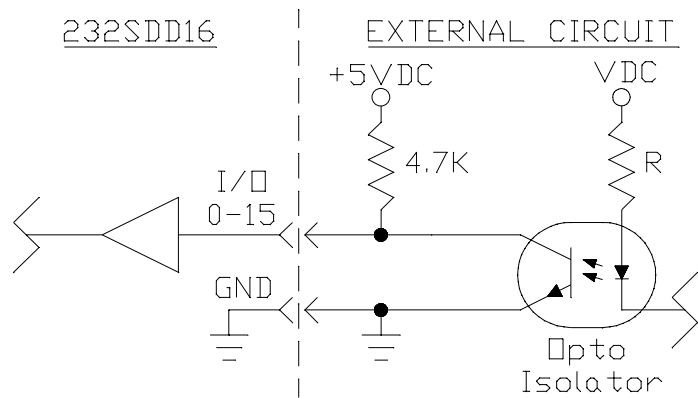

Figure 4.4 - Isolated Solid State Input

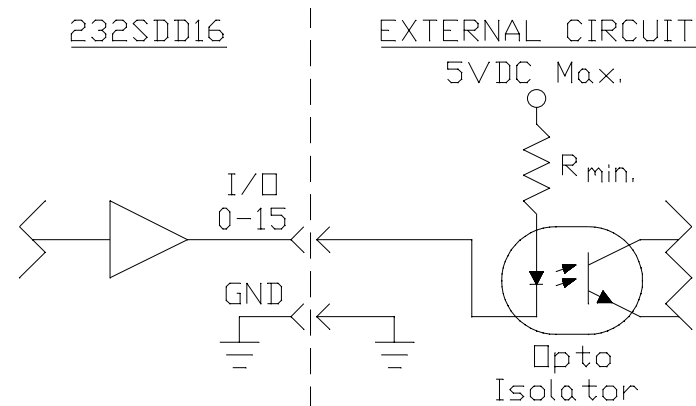

Figure 4.6 - Isolated Solid State Output

Digital Outputs

Digital outputs are used to turn external devices on or off. Digital outputs are CMOS/TTL compatible and operate between 0Vdc and +5Vdc. Outputs can be used to control solid state output modules, CMOS and TTL logic circuits. Caution must be taken not to exceed the power capability of the outputs. Refer to the output specifications in Chapter 1.

Setting an output line to a "1" forces the output HIGH, and setting an output line to a "0" forces the output LOW.

Figures 4.5 - 4.6 show examples of some typical output interfaces.

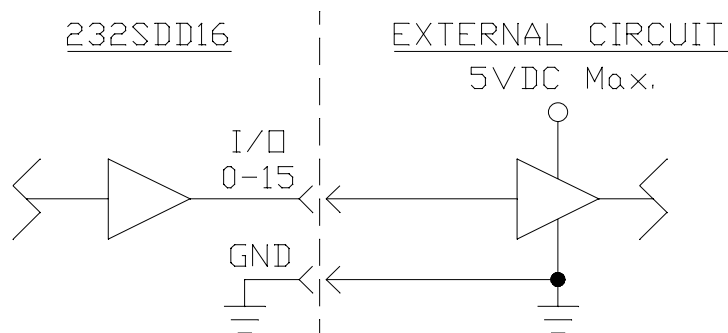

Figure 4.5 - Solid State Output

Chapter 5 - Software

This chapter will be divided into two sections. The first section covers programming techniques for constructing a command string, receiving data and manipulating data in QuickBASIC. The second section discusses how to install and run the demonstration program on an IBM PC or compatible.

Programming Techniques

This section shows steps and examples of programming the 232SDD16 in QuickBasic. If you are programming in another language, this section can be helpful as a guideline for programming the 232SDD16.

Read I/O States Command

Step 1 - Constructing the command string:

```
Cmnd$ = "IORD"
```

Step 2 - Transmitting the command string:

```
PRINT #1, Cmnd$;
```

Step 3 - Receiving the data:

```
MSIO$ = INPUT$(1,#1)
```

```
LSIO$ = INPUT$(1,#1)
```

Step 4 - Manipulating the data:

```
MSIO = ASC(MSIO$)
```

```
LSIO = ASC(LSIO$)
```

Step 5 - Determining an I/O's status:

```
MSstatus = MSIO AND mask
```

```
LSstatus = LSIO AND mask
```

By "ANDing" the value of **MSIO** or **LSIO** with the appropriate **mask** of an I/O line, the status of the I/O line can be determined.

If the status is equal to zero the I/O line is LOW. If the status is not equal to zero the I/O line is HIGH. Table 5.1 shows the **mask** values for each I/O line.

Step 6 - Repeat Step 5 until the status of each I/O line has been determined.

Example 5.1 - Determining the status of I/O lines #2 & #10

```
mask = &H4
```

```
Cmnd$ = "IORD"
```

```
PRINT #1, Cmnd$;
```

```
MSIO$ = INPUT$(1,#1)
```

```
LSIO$ = INPUT$(1,#1)
```

```
MSIO = ASC(MSIO$)
```

```
LSIO = ASC(LSIO$)
```

```
MSstatus = MSIO AND mask
```

```
LSstatus = LSIO AND mask
```

If **LSstatus** equals zero then I/O line #2 is LOW. If **LSstatus** is not equal to zero then I/O line #2 is HIGH. If **MSstatus** equals zero then I/O line #10 is LOW. If **MSstatus** is not equal to zero then I/O line #10 is HIGH.

Table 5.1 - Digital I/O Mask Values

I/O Line #	Mask Values	
	Hexadecimal	Decimal
0 & 8	1H	1
1 & 9	2H	2
2 & 10	4H	4
3 & 11	8H	8
4 & 12	10H	16
5 & 13	20H	32
6 & 14	40H	64
7 & 15	80H	128

Read Configuration Command

Step 1 - Constructing the command string:

```
Cmnd$ = "IORC"
```

Step 2 - Transmitting the command string:

```
PRINT #1, Cmnd$;
```

Step 3 - Receiving the data:

```
MSdefs$ = INPUT$(1,#1)
```

```
LSdefs$ = INPUT$(1,#1)
```

```
MSpups$ = INPUT$(1,#1)
```

```
LSpups$ = INPUT$(1,#1)
```

Step 4 - Manipulating the data:

```
MSdefs = ASC(MSdefs$)
```

```
LSdefs = ASC(LSdefs$)
```

```
MSpups = ASC(MSpups$)
```

```
LSpups = ASC(LSpups$)
```

Step 5 - Determining the I/O line definitions:

MSdefs = MSdefs AND mask

LSdefs = LSdefs AND mask

By "ANDing" the value of **MSdefs** or **LSdefs** with the appropriate **mask** of an I/O line, the I/O line definition can be determined. If the status is equal to zero the I/O line is an INPUT. If the status is not equal to zero the I/O line is an OUTPUT. Table 5.1 shows the **mask** values for each I/O line.

Step 6 - Repeat Step 5 until the status of each I/O line has been determined.

Step 7 - Determining an OUTPUT's Power-up state:

MSpups = MSpups AND mask

LSpups = LSpups AND mask

By "ANDing" the value of **MSpups** or **LSpups** with the appropriate **mask** of an Output line, the Output line definition can be determined. If the status is equal to zero the Output power-up state will be LOW. If the status is not equal to zero the Output power-up state will be HIGH. Table 5.1 shows the **mask** values for each I/O line.

Step 8 - Repeat Step 7 until the power-up state of each Output line has been determined.

Example 5.2 - Determining the definition and power-up state of I/O lines #2 & #10

mask = &H4

Cmnd\$ = "!0RC"

PRINT #1, Cmnd\$;

MSdefs\$ = INPUT\$(1,#1)

LSdefs\$ = INPUT\$(1,#1)

MSpups\$ = INPUT\$(1,#1)

LSpups\$ = INPUT\$(1,#1)

MSdefs = ASC(MSdefs\$)

LSdefs = ASC(LSdefs\$)

MSpups = ASC(MSpups\$)

LSpups = ASC(LSpups\$)

MSdefs = MSdefs AND mask

LSdefs = LSdefs AND mask

MSpups = MSpups AND mask

LSpups = LSpups AND mask

If **LSdefs** equals zero then I/O line #2 is an INPUT and if not equal to zero then I/O line #2 is an OUTPUT. If **MSdefs** equals zero then I/O line #10 is an INPUT and if not equal to zero then I/O line #10 is an OUTPUT. If **LSpups** equals zero then Output line #2's power-up state is LOW and if not equal to zero then Output line #2's power-up state is HIGH. If **MSpups** equals zero then Output line #10's power-up state is LOW and if not equal to zero then Output line #10's power-up state is HIGH.

Set Output States Command

Step 1a - Construct the command string:

Set appropriate outputs HIGH

MSstates = MSstates OR mask

LSstates = LSstates OR mask

By "ORing" the current states with the appropriate **mask** of a digital output line, the output's bit will be set to a "1" (HIGH).

Step 1b - Set appropriate outputs LOW

MSstates = MSstates AND (NOT(mask))

LSstates = LSstates AND (NOT(mask))

By "ANDing" the current states with the complement of the appropriate **mask** of a digital output line, the output's bit will be set to a "0" (LOW).

Step 1c - Completing the command string:

Cmnd\$ = "!0SO" + CHR\$(MSstates) + CHR\$(LSstates)

Step 2 - Transmitting the command string:

Print #1, Cmnd\$;

Example 5.3 - Set Output #0 HIGH and Output #14 LOW.

'Set bit 0 of LSstates to make Output #0 HIGH.

LSstates = LSstates OR &H1

'Clear bit 4 of MSstates to make Output #14 LOW.

MSstates = MSstates AND (NOT(&H40))

Cmnd\$ = "!0SO" + CHR\$(MSstates) + CHR\$(LSstates)

PRINT #1, Cmnd\$;

MSIO\$ = INPUT\$(1,#1)

Output #0 will be set HIGH and output #14 will be set LOW. All other output setting will not be changed.

Define I/O Lines Command

Step 1a - Construct the command string:

Define an I/O line as Output

MSdefs = MSdefs OR mask

LSdefs = LSdefs OR mask

By "ORing" the current definitions with the appropriate I/O line **mask**, the I/O line's data bit will be set to a "1" (HIGH) and the I/O line will be defined as an Output.

Step 1b - Define an I/O line as an Input

MSdefs = MSdefs AND (NOT(mask))

LSdefs = LSdefs AND (NOT(mask))

By "ANDing" the current definitions with the complement of the appropriate I/O line **mask** the I/O line's data bit will be set to a "0" (LOW) and the I/O line will be defined as an Input.

Step 1c - Completing the command string:

Cmnd\$ = "!0SD" + CHR\$(MSdefs) + CHR\$(LSdefs)

Step 2 - Transmitting the command string:

Print #1, Cmnd\$;

Example 5.4 - Define I/O line #7 as an Output (HIGH) and I/O line #8 as an input (LOW).

'Set bit 7 of LSdefs to make I/O line #7 an Output (HIGH).

LSdefs = LSdefs OR &H80

'Clear bit 0 of MSdefs to make I/O line #8 an Input (LOW).

MSdefs = MSdefs AND (NOT(&H1))

Cmnd\$ = "!0SD" + CHR\$(MSdefs) + CHR\$(LSdefs)

Print #1, Cmnd\$;

MSIO\$ = INPUT\$(1,#1)

I/O #7 will be defined as an Output (HIGH) and I/O line #8 will be defined as an Input (LOW). All other I/O definitions will not be changed.

Set Power-up States Command

Step 1a - Construct the command string:

Set appropriate outputs power-up states HIGH

MSpups = MSpups OR mask

LSpups = LSpups OR mask

By "ORing" the current power-up states with the appropriate **mask** of a digital output line, the power-up state's data bit will be set to a "1" (HIGH).

Step 1b - Set appropriate outputs power-up states LOW

MSpups = MSpups AND (NOT(mask))

LSpups = LSpups AND (NOT(mask))

By "ANDing" the current power-up states with the complement of the appropriate **mask** of a digital output line, the power-up state's data bit will be set to a "0" (LOW).

Step 1c - Completing the command string:

Cmnd\$ = "!0SS" + CHR\$(MSpups) + CHR\$(LSpups)

Step 2 - Transmitting the command string:

Print #1, Cmnd\$;

Example 5.5 - Set Output line #5's power-up state HIGH and Output line #13's power-up state LOW.

'Set bit 0 of LSpups to make Output #5's power-up state HIGH.

LSpups = LSpups OR &H20

'Clear bit 4 of MSpups to make Output #13's power-up state LOW.

MSpups = MSpups AND (NOT(&H20))

Cmnd\$ = "!0SS" + CHR\$(MSpups) + CHR\$(LSpups)

Print #1, Cmnd\$;

MSIO\$ = INPUT\$(1,#1)

Output #5's power-up state will be set HIGH and output #13's power-up state will be set LOW. All other output power-up states will not be changed.

Demonstration Program

The 232SDD16 Demonstration (SDD16) Program (IBM PC or Compatible) provides the user with examples of how to receive and transmit commands to the 232SDD16. The SDD16.EXE is the executable program, the SDD16.BAS file is the source code in QuickBASIC. The source code provides an illustration of how to send and receive commands from the 232SDD16.

NOTE: This is a demonstration program only and not intended for system applications.

Running Demonstration Program

Before you can run the demonstration program you must run the install program in the Hard Drive Installation section. If you are running Windows, exit Windows to DOS.

To run the program follow these steps from the DOS prompt:

1. Type **CD \232SDD16** and press the **<Enter>** key.
2. Type **SDD16** and press the **<Enter>** key.

APPENDIX A

ASCII Character Codes

DECIMAL to HEX to ASCII CONVERSION TABLE												
DEC	HEX	ASCII	KEY	DEC	HEX	ASCII	DEC	HEX	ASCII	DEC	HEX	ASCII
0	0	NUL	ctrl @	32	20	SP	64	40	@	96	60	`
1	1	SOH	ctrl A	33	21	!	65	41	A	97	61	a
2	2	STX	ctrl B	34	22	"	66	42	B	98	62	b
3	3	ETX	ctrl C	35	23	#	67	43	C	99	63	c
4	4	EOT	ctrl D	36	24	\$	68	44	D	100	64	d
5	5	ENQ	ctrl E	37	25	%	69	45	E	101	65	e
6	6	ACK	ctrl F	38	26	&	70	46	F	102	66	f
7	7	BEL	ctrl G	39	27	'	71	47	G	103	67	g
8	8	BS	ctrl H	40	28	(72	48	H	104	68	h
9	9	HT	ctrl I	41	29)	73	49	I	105	69	i
10	A	LF	ctrl J	42	2A	*	74	4A	J	106	6A	j
11	B	VT	ctrl K	43	2B	+	75	4B	K	107	6B	k
12	C	FF	ctrl L	44	2C	,	76	4C	L	108	6C	l
13	D	CR	ctrl M	45	2D	-	77	4D	M	109	6D	m
14	E	SO	ctrl N	46	2E	.	78	4E	N	110	6E	n
15	F	SI	ctrl O	47	2F	/	79	4F	O	111	6F	o
16	10	DLE	ctrl P	48	30	0	80	50	P	112	70	p
17	11	DC1	ctrl Q	49	31	1	81	51	Q	113	71	q
18	12	DC2	ctrl R	50	32	2	82	52	R	114	72	r
19	13	DC3	ctrl S	51	33	3	83	53	S	115	73	s
20	14	DC4	ctrl T	52	34	4	84	54	T	116	74	t
21	15	NAK	ctrl U	53	35	5	85	55	U	117	75	u
22	16	SYN	ctrl V	54	36	6	86	56	V	118	76	v
23	17	ETB	ctrl W	55	37	7	87	57	W	119	77	w
24	18	CAN	ctrl X	56	38	8	88	58	X	120	78	x
25	19	EM	ctrl Y	57	39	9	89	59	Y	121	79	y
26	1A	SUB	ctrl Z	58	3A	:	90	5A	Z	122	7A	z
27	1B	ESC	ctrl [59	3B	;	91	5B	[123	7B	{
28	1C	FS	ctrl \	60	3C	<	92	5C	\	124	7C	
29	1D	GS	ctrl]	61	3D	=	93	5D]	125	7D	}
30	1E	RS	ctrl ^	62	3E	>	94	5E	^	126	7E	~
31	1F	US	ctrl _	63	3F	?	95	5F	_	127	7F	DEL

The decimal (base 10) numbering system represents each position in successive powers of 10, with each decimal symbol having a value from 0 to 9. The hexadecimal (base 16) numbering system represents each position in successive powers of 16 with each hex symbol having a value of 0 to 15. Since each hex position must have a single symbol, the symbols "A" through "F" are assigned to values 10 through 15 respectively. Refer to Table 1. The information and examples to follow will explain how to convert from a decimal number to a hexadecimal number and vice versa.

Table 1.

Decimal Value	Hexadecimal Symbol
0	0
1	1
2	2
3	3
4	4
5	5
6	6
7	7
8	8
9	9
10	A
11	B
12	C
13	D
14	E
15	F

APPENDIX B

Hexadecimal/Decimal Conversions

Hexadecimal to Decimal Conversion:

Decimal = (1st Hex digit x 4096) +
 (2nd Hex digit x 256) +
 (3rd Hex digit x 16) +
 (4th Hex digit)

Each "Hex digit" is the decimal equivalent value of the hexadecimal symbol.

Example: Convert 10FC hexadecimal to decimal.

$$\begin{array}{r}
 1 \times 4096 = 4096 \\
 0 \times 256 = 0 \\
 15 \times 16 = 240 \\
 12 \times 1 = 12 \\
 \hline
 4348
 \end{array}$$

10FC hex equals 4348 decimal.

Decimal to Hexadecimal Conversion:

Example: Convert 4348 decimal to hexadecimal.

$$\begin{array}{r}
 4096 \overline{) 4348} = 1 = 1 \text{ (1st Hex digit)} \\
 \underline{4096} \\
 256 \overline{) 252} = 0 = 0 \text{ (2nd Hex digit)} \\
 \underline{0} \\
 16 \overline{) 252} = 15 = F \text{ (3rd Hex digit)} \\
 \underline{240} \\
 1 \overline{) 12} = 12 = C \text{ (4th Hex digit)} \\
 \underline{12} \\
 0
 \end{array}$$

4348 decimal equals 10FC hexadecimal.

APPENDIX C

Interface Modules for SDD16 Models

DTB25

The DTB25 connects to the SDD16 models to provide easy access to the available I/O lines. The DTB25 plugs directly into the SDD16's DB25S I/O Port connector. Each of the twenty-five pins on the connector is brought out to a terminal block. Refer to Table C.1. Dimensions: 0.5" x 2.1" x 4.3". An enclosure for the DTB25 is available.

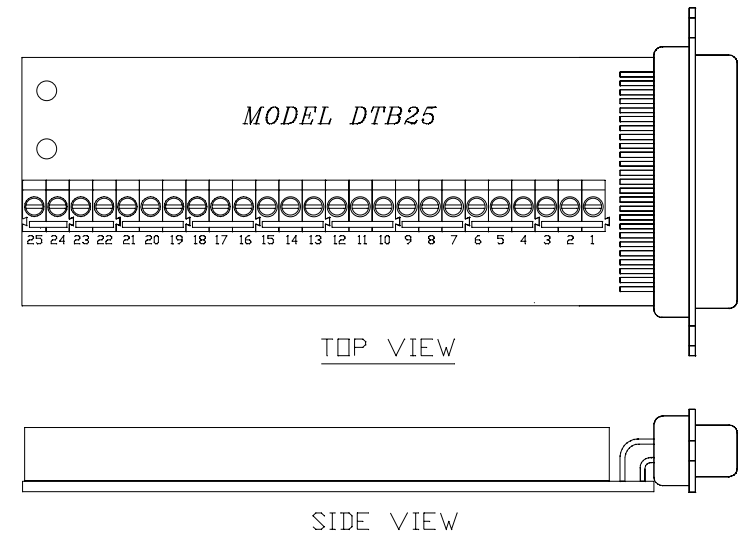

Figure C.1 - DTB25 Outline Drawing

Before connecting any external devices to the DTB25 make sure the SDD16 module has been properly configured (I/O lines defined, power-up states set). This will avoid possible damage to the module and to the external devices. Make sure not to exceed the voltage and current limits of the SDD16 module, failure to do so could result in damage to the module and will void the warranty. Refer to the Specification Section of this Manual.

Table C.1 - DTB25 Connections

DB-25P Pin #	Function	T.B. #	DB-25P Pin #	Function	T.B. #
1	Unused.	1	14	I/O #15	14
2	Unused.	2	15	I/O #14	15
3	Unused.	3	16	I/O #13	16
4	Unused.	4	17	I/O #12	17
5	Unused.	5	18	I/O #11	18
6	Unused.	6	19	I/O #10	19
7	Ground	7	20	Unused.	20
8	+12Vdc Input	8	21	I/O #9	21
9	I/O #0	9	22	I/O #8	22
10	I/O #1	10	23	I/O #7	23
11	I/O #2	11	24	I/O #6	24
12	I/O #3	12	25	I/O #5	25
13	I/O #4	13			

DBM16

The DBM16 module provides buffering and increased power handling for all the sixteen I/O lines of the SDD16 models. Each of the I/O lines can be programmed as an input or as an output by setting a jumper on the board. The DBM16 plugs directly into the SDD16's DB25S I/O Port connector. Terminal blocks are provided for all I/O line, power, and ground connections. Refer to Table C.2. An enclosure for the DBM16 is available.

Table C.2 - DBM16 I/O Connections

T.B.1 Label	Function	T.B.2 Label	Function
I/O7	I/O Line #7	I/O8	I/O Line #8
GND	Ground	GND	Ground
I/O6	I/O Line #6	I/O9	I/O Line #9
I/O5	I/O Line #5	I/O10	I/O Line #10
GND	Ground	GND	Ground
I/O4	I/O Line #4	I/O11	I/O Line #11
I/O3	I/O Line #3	I/O12	I/O Line #12
GND	Ground	GND	Ground
I/O2	I/O Line #2	I/O13	I/O Line #13
I/O1	I/O Line #1	I/O14	I/O Line #14
GND	Ground	GND	Ground
I/O0	I/O Line #0	I/O15	I/O Line #15
GND	Ground		
+12	+12Vdc Input		
ITS	Inductive-load Transient Suppression		

DBM16 Interfacing

This section will show some general examples of how to interface the DBM16 I/O lines to external devices. Caution must be taken not to exceed the DBM16 specifications, failure to do so could result in damage to the DBM16 and will void the warranty.

Before connecting the DBM16 to the SDD16 module and connecting any external device to the DBM16 determine which I/O lines on the SDD16 module are inputs and which are outputs. Once the inputs and outputs are known, set the jumpers on the DBM16 accordingly. Refer to Figure C.2.

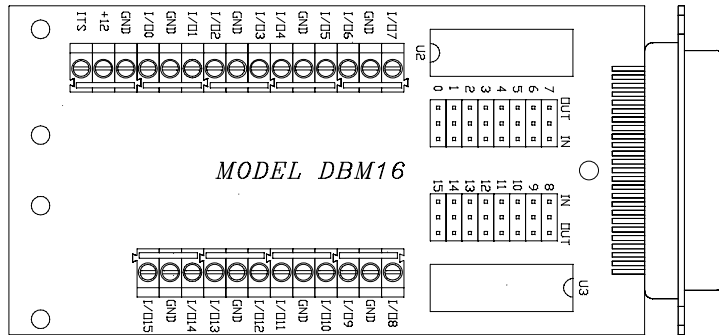

Figure C.2 - DBM16 Outline Drawing

Inputs

Digital inputs are used to sense "HIGH" and "LOW" states based on voltage levels. This is accomplished via switch closures, contact closures or a solid state digital signals. Each DBM16 input is pulled up through a resistor and will be read as a logic "1" (HIGH) by the SDD16 module. When an input on the DBM16 is grounded (below +1.5Vdc), a logic "0" (LOW) will be read by the SDD16 module. Figures C.3 - C.6 show examples of some typical input interfaces.

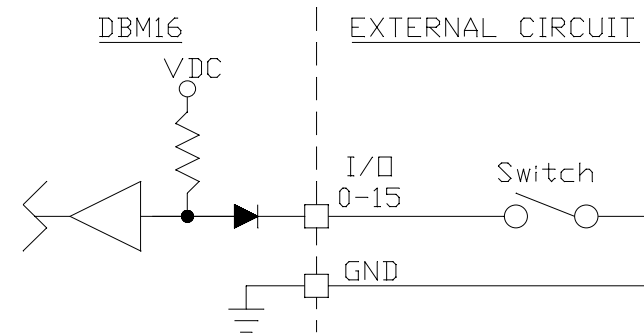

Figure C.3 - Switch Input

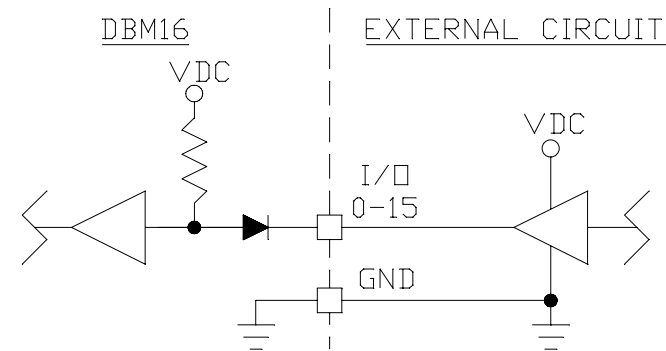

Figure C.4 - Solid State Input

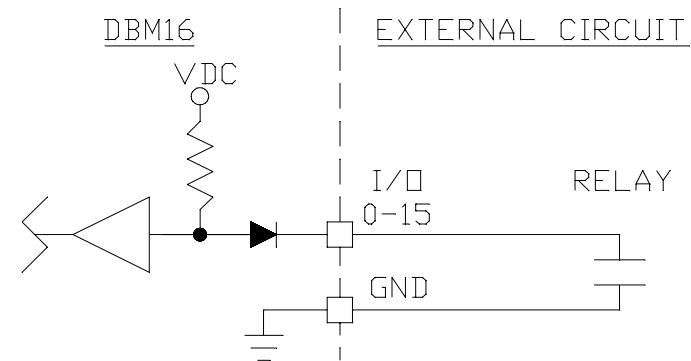

Figure C.5 - Isolated Mechanical Input

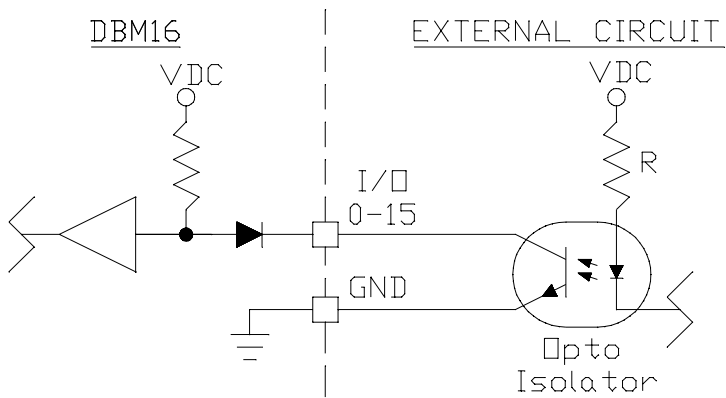

Figure C.6 - Isolated Solid State Input

Outputs

Digital outputs are used to turn "ON" or turn "OFF" external devices. Outputs can be used to control solid state output modules, logic circuits, and relays. Caution must be taken not to exceed the power capability of the outputs. Refer to the DBM16 output specifications.

Setting the SDD16 module's output line to a "1" turns "ON" the DBM16's output line. Setting the SDD16 module's output line to a "0" turns "OFF" the DBM16's output driver. The DBM16 outputs are open collector current sinking drivers. Figures C.7 - C.9 show examples of some typical output interfaces.

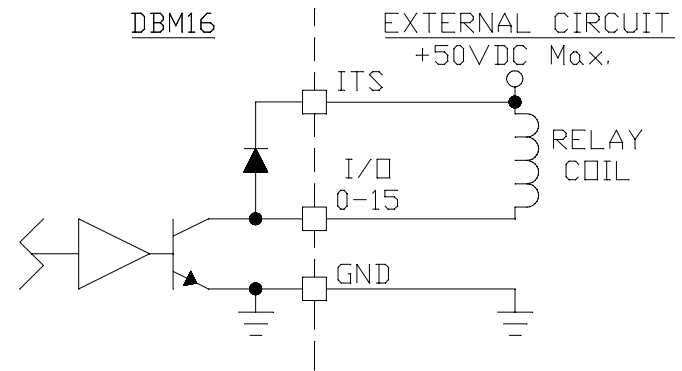

Figure C.8 - Isolated Mechanical Output

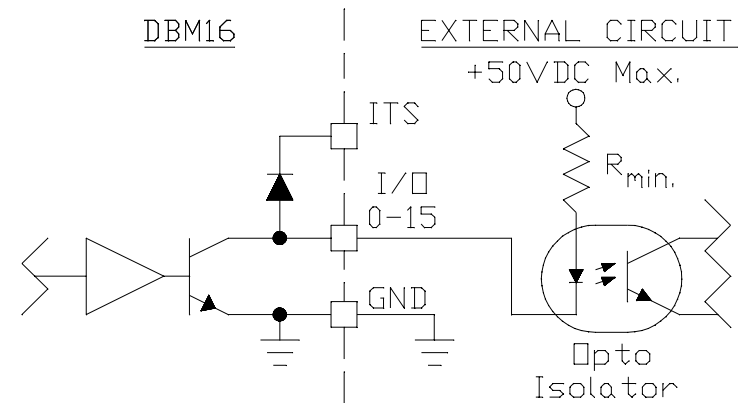

Figure C.9 - Isolated Solid State Output

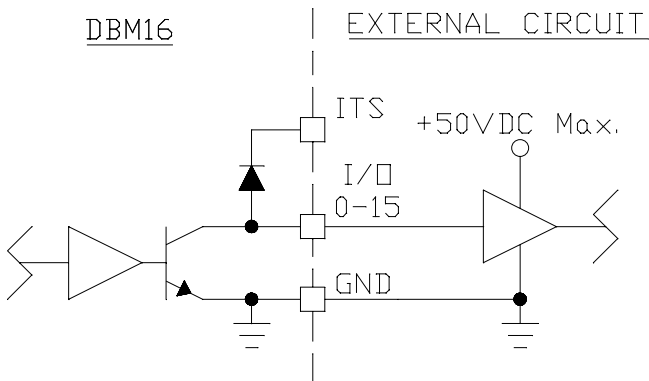

Figure C.7 - Solid State Output

DBM16 Specifications

I/O Lines

Total: 16 (Factory default - set to inputs)

Inputs

Voltage range: 0Vdc to +50Vdc
 Low Voltage: 0Vdc to +1.5Vdc
 High Voltage: +2.5Vdc to +50Vdc
 Internal pull-up current: 0.5 ma

Outputs

Output Voltage: +50Vdc max.
 Output current: 350 ma max. - only 1 output on
 100 ma max. - all outputs on
 Output leakage current: 50 micro amp max.
 Output saturation voltage: 1.1Vdc max. @ 100ma

CAUTION: Total output power cannot exceed 2 watts for I/O's #0-7 and 2 watts for I/O #8-15 @ 25 degrees C.

Power Supply

Input Voltage: 8Vdc to 16Vdc @ 10milliamps
 (Doesn't include the power consumption of external devices.)

Connections:

Size 0.5" x 2.1" x 4.5"

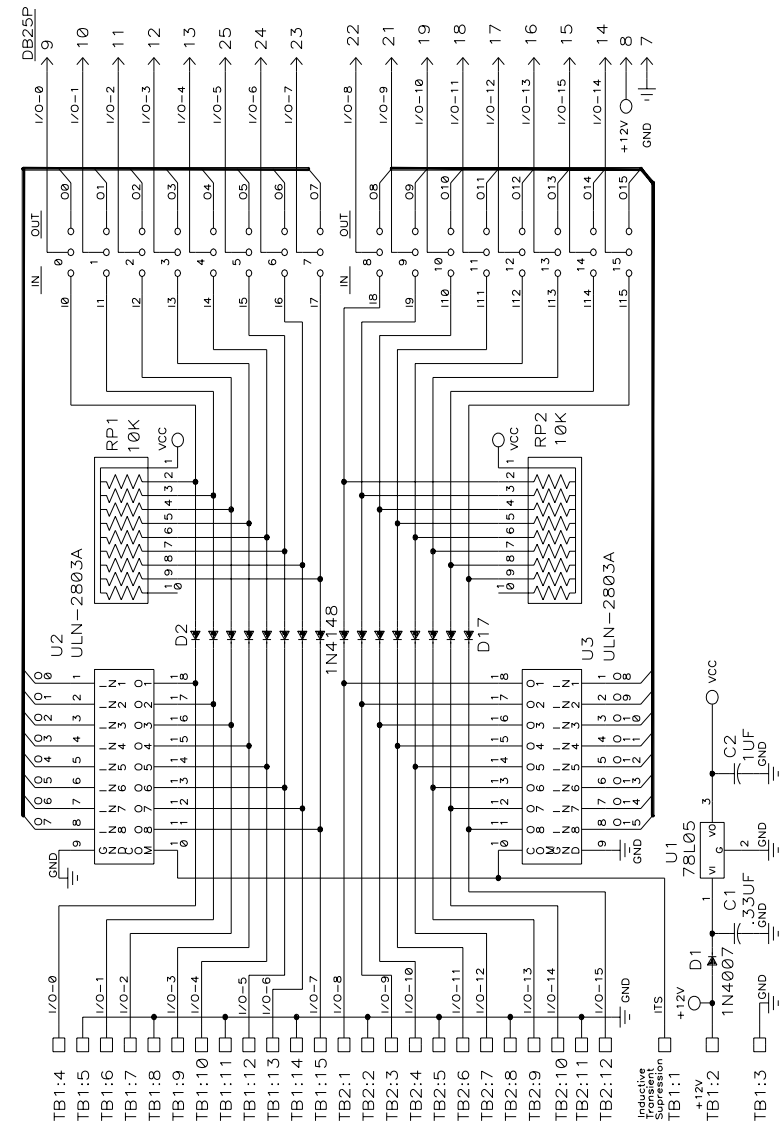

Figure C.10 - DBM16 Schematic

Appendix D

Adding Data Field Confirmation

With serial communications in a laboratory environment, the possibility of a communication error occurring is minimal. However, in a harsh or an industrial environment the possibility increases. A communication error occurs when a bit transmitted as a "1" is received as a "0" or vice versa. If the 232SDD16 receives a error in one or more of the first four command characters ("!0xx"), the unit will not execute the command. However, if the 232SDD16 receives an communication error on a data byte (I/O byte for Read Digital command or state byte for Set Output State command), the command will be executed since the unit has no way of knowing that there was an error.

To provide the 232SDD16 with a way of detecting errors in the data fields, an additional set of commands can be used. This set of commands begins with the "#" (23h) character, instead of the "!" (21h) character. Refer to Table D-1. With these commands every data byte that is transmitted or received is followed by it's complement. For example: To read I/O lines:

Command syntax:

#ORD

Response syntax:

{I/O msb}{~ I/O msb}{I/O lsb} {~ I/O lsb}

Where "~" is used to indicate the "complement of." If I/O has a reading of 1, the following would be received:

{00}{FF}{01}{FE}

Where FFh is the complement of 0 and FEh is the complement of 1. The complement of number "x" can be calculated in QuickBasic as follows:

comp = (NOT x) AND &HFF

Table D-1 Extended Commands

Function	Command	Response
Read I/O Lines	#0RD	{I/O msb}{~I/O msb}{I/O lsb}{~I/O lsb}
Set Output Lines	#0SO{I/O msb}{~I/O msb}{I/O lsb}{~I/O lsb}	no response
Define I/O Lines	#0SD{I/O msb}{~I/O msb}{I/O msb}{~I/O msb}	no response
Set Power-up States	#0SS{I/O msb}{~I/O msb}{I/O lsb}{~I/O lsb}	no response
Read Configuration	#0RC	{I/O msb}{~I/O msb}{I/O lsb}{~I/O lsb}{I/O powerup msb states}{~I/O powerup msb states}{I/O powerup lsb states}{~I/O powerup lsb}

Where "x" is the required data byte and "~" signifies the complement of the specified byte.