

Send RS-232, 422 or 485 Signals Out To Four Fiber Optic Ports $\text{C}\epsilon$ At Distances Up To 2.5 Miles Model FDF4SE

Description:

The FDF4SE is designed to provide communication from one asynchronous serial port to four fiber optic ports at distances up to 2.5 miles. The FDF4SE is expandable, allowing two or more FDF4SE devices to be cascaded together. Each additional FDF4SE adds four more fiber optic ports communicating with one Master port. The converter is set up for a multi-drop Master/Slave configuration, allowing one "Master" asynchronous serial device to talk to any number of "Slave" devices while providing the EMI/RFI and transient immunity of optical fiber.

RS-232 data signals at up to 115.2kbps and RS-422 or RS-485 data signals at up to 460kbps are supported. The FDF4SE supports both the Transmit and Receive data lines, and provides full hardware control of the RS-422/485 driver with B&B's automatic Send Data control circuit. Timeouts are dip-switch selectable between 0.10 and 2.2 ms. All serial connections are provided on the same DB-25 female connector; the multimode fiber is connected via ST connectors; and RJ-45 connectors are used for the expansion port.

The unit must be powered with 10-30 VDC (370 mA @ 10V). Power can be supplied through either the power jack, the DB-25 female pin 25(+) and pin 12(-), or the terminal block located inside the enclosure.



Figure 1: Typical Setup

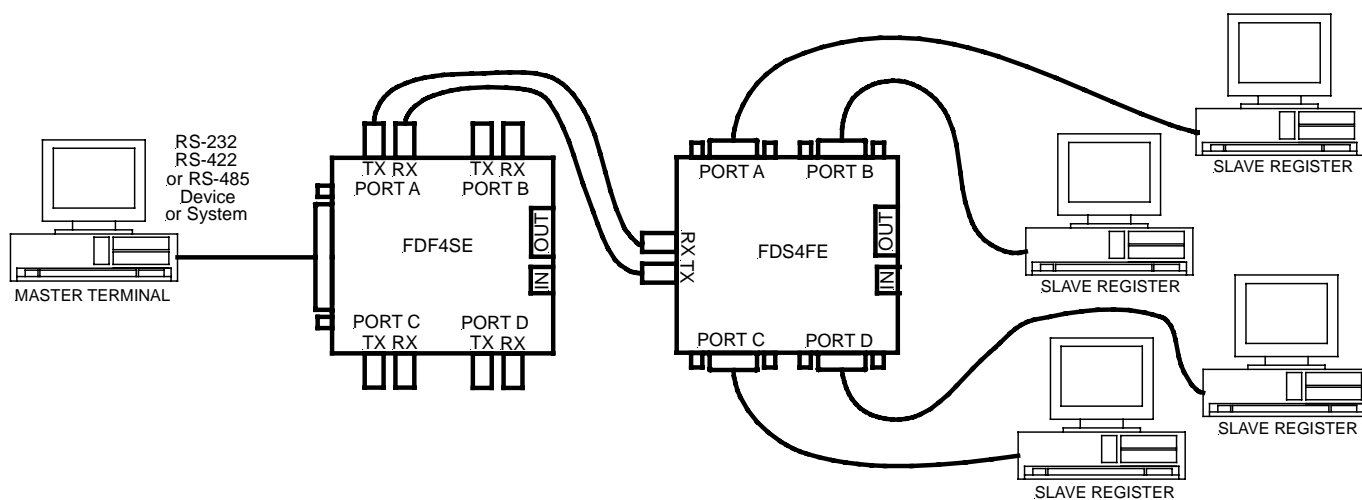

RS-232 Connections:

The DB-25 female serial connector is used for connecting to RS-232, RS-422 or RS-485. The RS-232 signals are pinned as a DCE device (input on pin 2 and output on pin 3). A straight through cable can be used from the DB-25 port on any DTE device such as a PC or terminal. A standard 9 to 25-pin adapter can be used in cases where the serial port on the DTE device is a DB-9. A null modem cable or adapter that swaps pins 2 and 3 is needed for connecting to modems or other DCE devices. See Figure 2 for connection diagrams to 9 pin and 25 pin DTE and DCE devices. Because RS-422 and RS-485 signals are also available on the same connector, take special care not to hook any external signals to these pins. This is not a problem for most serial devices, but a custom cable must be made that does not connect to the extra pins on the DB-25 connector if your device has power or special non-standard outputs.

B&B Electronics -- October 2001

This product designed and manufactured in USA of domestic and imported parts by

B & B Electronics Mfg. Co.

707 Dayton Road - P.O. Box 1040 - Ottawa, IL 61350 USA
Phone: (815) 433-5100 - Fax: (815) 433-5105

Home Page: www.bb-elec.com

Sales e-mail: orders@bb-elec.com - Fax: (815) 433-5109

Technical Support e-mail: support@bb-elec.com - Fax: (815) 433-5104

B & B Electronics Ltd

Westlink Commercial Park - Oranmore, Co. Galway - Ireland
Phone: +353 91 792444 - Fax: +353 91 792445

Home Page: www.bb-europe.com

Sales e-mail: orders@bb-europe.com

Technical Support e-mail: support@bb-europe.com

RS-422 & RS-485 Connections:

The RS-422/485 driver and receiver are connected to four pins on the DB-25 connector. Signal ground is on pin 7. When connecting to a four-wire RS-422/485 device or system, connect the output of your device to pins 16 RD(B+) and 17 RD(A-). Connect the input to your device to pins 14 TD(B+) and 15 TD(A-). For two-wire RS-485 systems, the driver and receiver of the FDF4SE must be connected by tying pins 14 and 16 together and 15 and 17 together. This allows the FDF4SE to communicate half-duplex over the same pair. Refer to Figure 2 for connection diagrams to your RS-422 or RS-485 equipment.

Figure 2: RS-232 Connection Diagrams

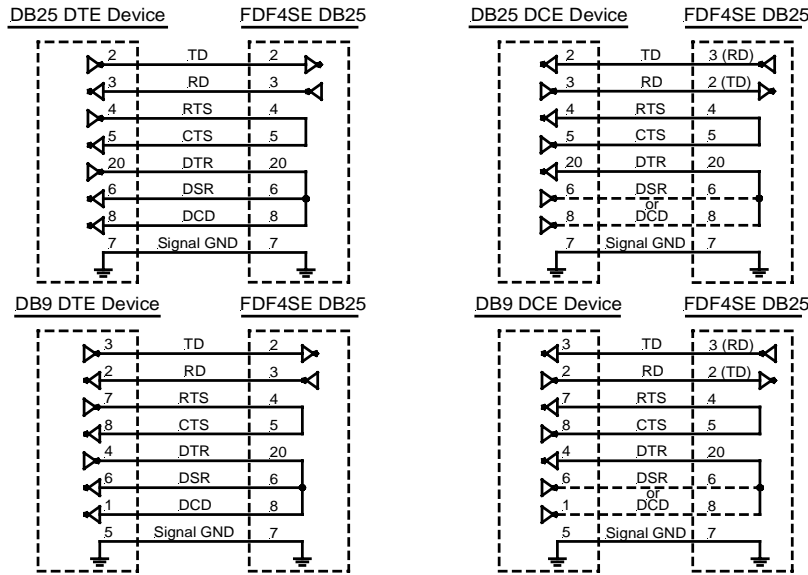

If termination is needed, a spot on the PCB labeled R2 allows you to solder in a termination resistor across the RD(A-) and RD(B+) lines. The off-state bias resistor values can be changed by removing R1 and R3, and replacing them with through-hole components, R4 and R5. Before making modifications to the FDF4SE, be sure to consult B&B Electronics' free RS-422/485 Application Note or other sources of information to see if termination is necessary. The RS-422/485 Application Note is available from our Web site, or call B&B to have a copy mailed to you at no charge.

Figure 3: RS-422/485 Connection Diagrams

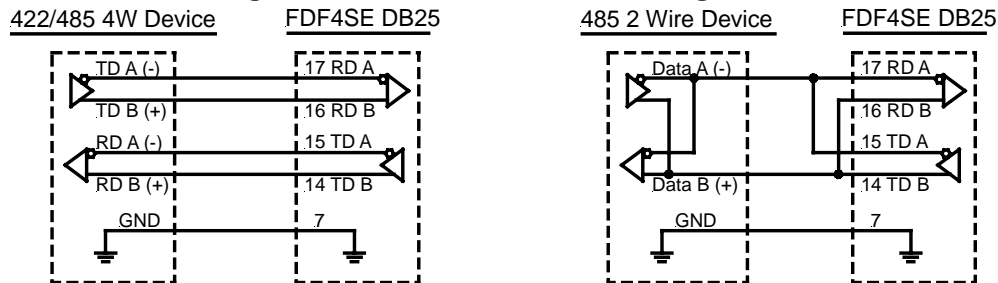

Expansion Port Connections:

The expansion port utilizes RS-422 data signals with RJ-45 connectors. To use the expansion feature simply connect a cable from the OUT of the upstream device to the IN of the next device.

If termination is needed, a spot on the PCB labeled R25 for the OUT connection and R29 for the IN connection allows you to solder in a termination resistor across the RD(A-) and RD(B+) lines. The off-state bias resistor values can be changed by removing R26 and R27, for the OUT side of the expansion port, and replacing them with through-hole components in the spots labeled R31 and R28. For the IN side of the expansion port, remove R23 and R30, and replace them with through-hole components in the spots labeled R24 and R32.

B&B Electronics -- October 2001

This product designed and manufactured in USA of domestic and imported parts by

B & B Electronics Mfg. Co.

707 Dayton Road - P.O. Box 1040 - Ottawa, IL 61350 USA
 Phone: (815) 433-5100 - Fax: (815) 433-5105

Home Page: www.bb-elec.com

Sales e-mail: orders@bb-elec.com - Fax: (815) 433-5109

Technical Support e-mail: support@bb-elec.com - Fax: (815) 433-5104

B & B Electronics Ltd

Westlink Commercial Park - Oranmore, Co. Galway - Ireland
 Phone: +353 91 792444 - Fax: +353 91 792445

Home Page: www.bb-europe.com

Sales e-mail: orders@bb-europe.com

Technical Support e-mail: support@bb-europe.com

Fiber Optic Connections:

The FDF4SE uses a separate LED emitter and photo-detector operating at an 820 nm wavelength. Connections to the emitter and detector are done with ST type connectors. Almost any multimode glass fiber size can be used including 50/125 µm, 62.5/125 µm, 100/140 µm, and 200 µm. Two fibers are required between the two devices, one each direction of data. See Figure 1 for a typical multi-drop configuration using an FDF4SE and an FDS4FE. The model FDS4FE was designed in conjunction with the FDF4SE to take RS-232/422/485 data, send it across fiber optic lines, and broadcast it out to 4 serial ports.

The most important consideration in planning the fiber optic link is the “power budget” of the fiber device. This value represents the amount of loss in dB that can be present in the link between the two fiber devices before the units fail to perform properly. This value includes line attenuation as well as connector loss. For the FDF4SE the typical connector-to-connector power budget is 12.1 dB. Because 62.5/125 µm cable typically has a line attenuation of 3 dB per Km at 820 nm, the 12.1 dB power budget translates into 2.5 miles. This assumes no extra connectors or splices in the link. Each extra connection would typically add 0.5 dB of loss, reducing the possible distance by 167 m (547 ft.). The actual loss should be measured before assuming distances.

Dip-Switch Setup:

The Dip-Switch (SW1) on the FDF4SE defines the mode of operation when being used for RS-422 or RS-485. Positions 4 through 8 on the switch determine the timeout of the RS-485 driver. Because the driver is controlled by hardware, a specific time must be set to tell the hardware how long to wait for data on the fiber side before turning off the RS-422/485 driver. If this time is set too short, the driver could be disabled before transmission is complete, resulting in data corruption. If the time is set too long, the RS-485 device may respond before the RS-422/485 driver in the FDF4SE is disabled, corrupting this response. We recommend that the timeout be set for approximately one character time or longer. The character times for several different baud rates are selectable on switch positions 4 through 8. If you need a different timeout than what is provided, R18 can be removed and replaced with a different value R17. Table 1 shows the different timeout values for the switch positions as well as some typical R17 replacement values.

Table 1: RS-485 Timeout Selection

Baud Rate	Pos. 8	Pos. 7	Pos. 6	Pos. 5	Pos. 4	R17	Time(ms)
1200	ON	OFF	OFF	OFF	OFF	820 KΩ	8.20
2400	ON	OFF	OFF	OFF	OFF	430 KΩ	4.30
4800	OFF	OFF	OFF	OFF	ON	Not Used	2.20
9600	OFF	OFF	OFF	ON	OFF	Not Used	1.30
19.2K	OFF	OFF	ON	OFF	OFF	Not Used	0.56
38.4K	OFF	ON	OFF	OFF	OFF	Not Used	0.27
57.6K	ON	OFF	OFF	OFF	OFF	Not Used	0.22
76.8K	ON	OFF	ON	ON	OFF	Not Used	0.14
115.2K	ON	ON	ON	OFF	OFF	Not Used	0.10
153.6K	ON	OFF	OFF	OFF	OFF	6.2 KΩ	0.06
230.4K	ON	OFF	OFF	OFF	OFF	4.3 KΩ	0.04
460.8K	ON	OFF	OFF	OFF	OFF	2.2 KΩ	0.02

Positions 1 and 2 of SW1 determine when the RS-422/485 driver and receiver are enabled. Position 2 controls the driver, and Position 1 controls the receiver. For RS-422 operation, set both switches to the “Off” position. For multi-drop RS-485 four-wire systems, position 2 should be “On” and position 1 should be “Off.” This allows the receiver to be enabled all of the time and eliminates some possible timing problems. For RS-485 two-wire systems, both switches should be in the “On” position. This disables the RS-422/485 receiver whenever the driver is enabled, preventing data from being echoed back to the fiber side. Table 2 illustrates the switch settings for typical setups.

Table 2: 422/485 Switch Settings

	Position 2 TX Enable	Position 1 RX Enable
RS-485 2-Wire Mode (Half duplex)	ON	ON
RS-485 4-Wire Mode (Full duplex)	ON	OFF
RS-422 Mode (Full duplex)	OFF	OFF

B&B Electronics -- October 2001

This product designed and manufactured in USA of domestic and imported parts by

B & B Electronics Mfg. Co.

707 Dayton Road - P.O. Box 1040 - Ottawa, IL 61350 USA
Phone: (815) 433-5100 - Fax: (815) 433-5105

Home Page: www.bb-elec.com

Sales e-mail: orders@bb-elec.com - Fax: (815) 433-5109

Technical Support e-mail: support@bb-elec.com - Fax: (815) 433-5104

B & B Electronics Ltd

Westlink Commercial Park - Oranmore, Co. Galway - Ireland
Phone: +353 91 792444 - Fax: +353 91 792445

Home Page: www.bb-europe.com

Sales e-mail: orders@bb-europe.com

Technical Support e-mail: support@bb-europe.com

Specifications:

- Transmission Line: Dual multimode optical cable
- Interfaces: RS-232, RS-422, or RS-485
- Data Rates: Up to 115.2kbps RS-232
Up to 460kbps RS-422/485
- Typical Range: Up to 2.5 miles on multimode glass fiber
- Coupled Power Budget: 12.1 dB
- Optic Wavelength: 820 nm
- Connectors: DB-25 female for serial connection,
ST for fiber; RJ-45 for expansion port
- Power Requirements: 10–30 VDC (370 mA @ 10V)
- Dimensions: 5.6 x 3.8 x 1.3in (14.1 x 9.7 x 3.2cm)



DECLARATION OF CONFORMITY	
Manufacturer's Name:	B&B Electronics Manufacturing Company
Manufacturer's Address:	P.O. Box 1040 707 Dayton Road Ottawa, IL 61350 USA
Model Numbers:	FDF4SE
Description:	Serial to Fiber Optic Converter Hub
Type:	Light industrial ITE equipment
Application of Council Directive:	89/336/EEC
Standards:	EN 50082-1:1998 EN 61000 -4(-2, -3, -4, -6) ENV 50204
 Michael J. Fahrion, Director of Engineering	
	

Figure 4: FDF4SE Circuit Diagram



B&B Electronics -- October 2001

This product designed and manufactured in USA of domestic and imported parts by

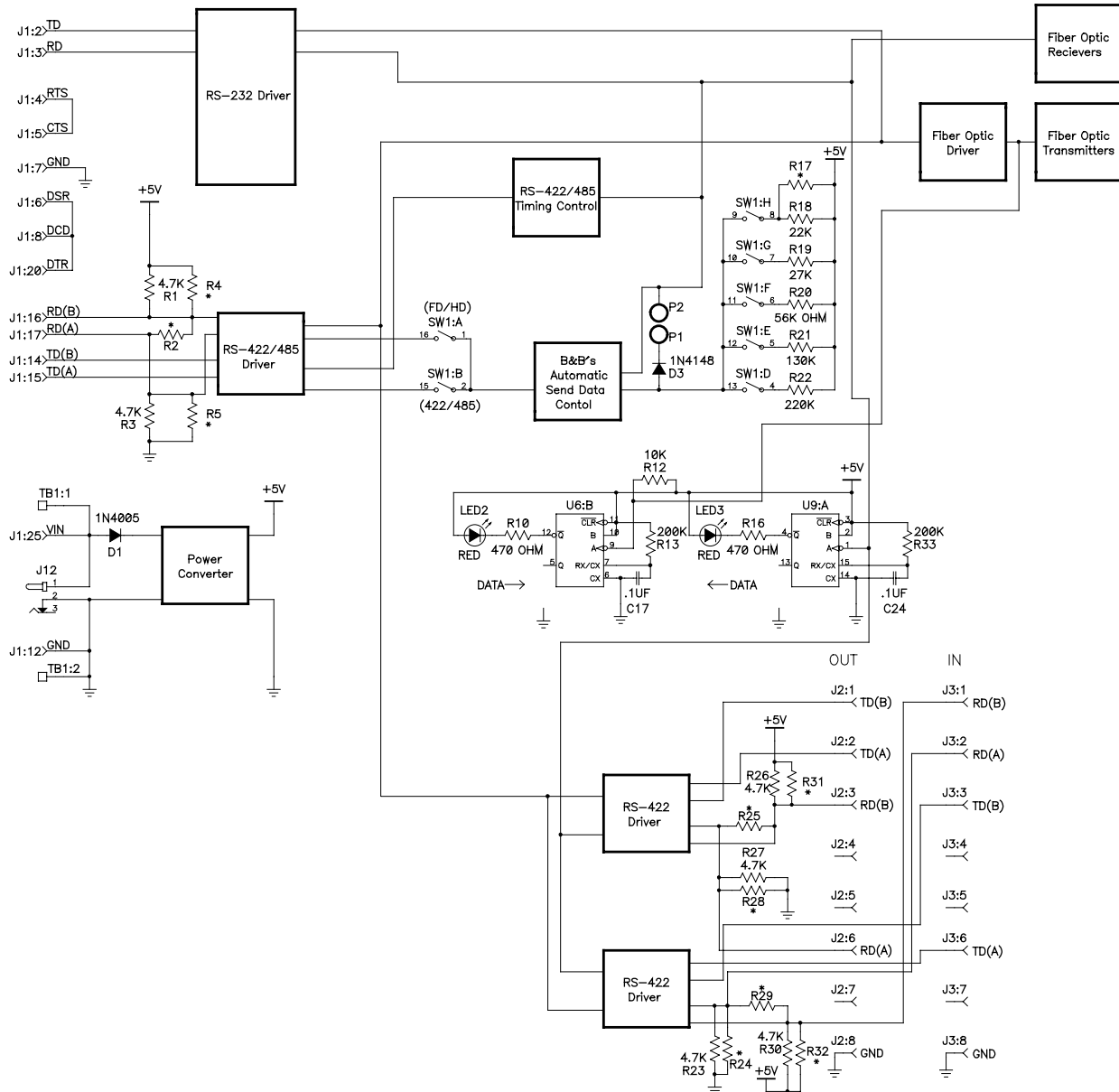
B & B Electronics Mfg. Co.

707 Dayton Road - P.O. Box 1040 - Ottawa, IL 61350 USA
 Phone: (815) 433-5100 - Fax: (815) 433-5105

Home Page: www.bb-elec.com
 Sales e-mail: orders@bb-elec.com - Fax: (815) 433-5109
 Technical Support e-mail: support@bb-elec.com - Fax: (815) 433-5104

B & B Electronics Ltd

Westlink Commercial Park - Oranmore, Co. Galway - Ireland
 Phone: +353 91 792444 - Fax: +353 91 792445

Home Page: www.bb-europe.com
 Sales e-mail: orders@bb-europe.com
 Technical Support e-mail: support@bb-europe.com