

## Product Specification

**TITLE: Y(B)8963 Black or Gold anodized 896-970MHz fully welded  
3 elements 6dBd Directional Yagi**

Part #: **Y(B)8963**  
Memo: **Spec**  
Page: **1 of 5**  
Date: **4/12/2006**

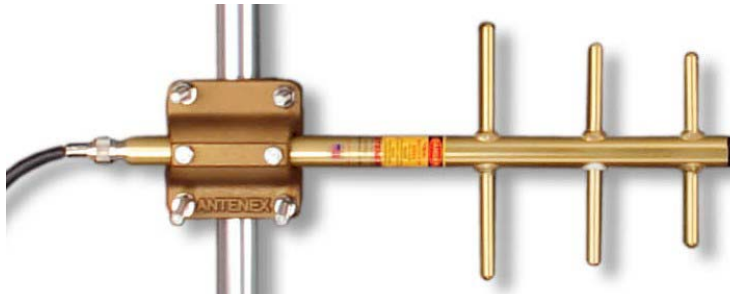

### **ELECTRICAL**

<b>Frequency Range:</b>	896 - 970 MHz
<b>Frequency Bandwidth:</b>	74 MHz
<b>VSWR:</b>	< 2.0:1
<b>Return Loss:</b>	-10dB max
<b>Nominal Gain:</b>	6 dBd
<b>Front to Back Ratio:</b>	20 dB
<b>Maximum Power:</b>	300 W
<b>Nominal Impedance:</b>	50Ω
<b>Polarization:</b>	Vertical or Horizontal
<b>Pattern:</b>	Directional
<b>Horizontal Beamwidth:</b> (For Horizontal Polarization)	89°
<b>Vertical Beamwidth:</b> (For Vertical Polarization)	65°
<b>Tuning:</b>	Fixed Tune
<b>Transmitting / Receiving:</b>	Both

### **MOUNTING**

**Included:** Heavy Duty Cast mount bracket accommodates 7/8" mast

### **MECHANICAL**

<b>Material:</b>	Aluminum
<b>Length:</b>	16-3/4"
<b>Height:</b>	7.125"
<b>Boom Diameter:</b>	0.875"
<b>Weight:</b>	3.28 lbs
<b>Rated Wind Velocity:</b>	150mph (241kph)
<b>Rated Wind Velocity (with 0.5" radial ice)</b>	80mph (130kph)
<b>Equivalent Flat Area:</b>	0.1918sq. ft.
<b>Cable:</b>	None
<b>Termination:</b>	N-female connector
<b>Color:</b>	Gold or Black Anodized
<b>Lightning Protection:</b>	Lightning Arrestor LABH350NN (Sold Separately)



## Product Specification

**TITLE: Y(B)8963 Black or Gold anodized 896-970MHz fully welded  
3 elements 6dBd Directional Yagi**

Part #: **Y(B)8963**  
Memo: **Spec**  
Page: **2 of 5**  
Date: **4/12/2006**

## ANTENNA RADIATION PATTERN

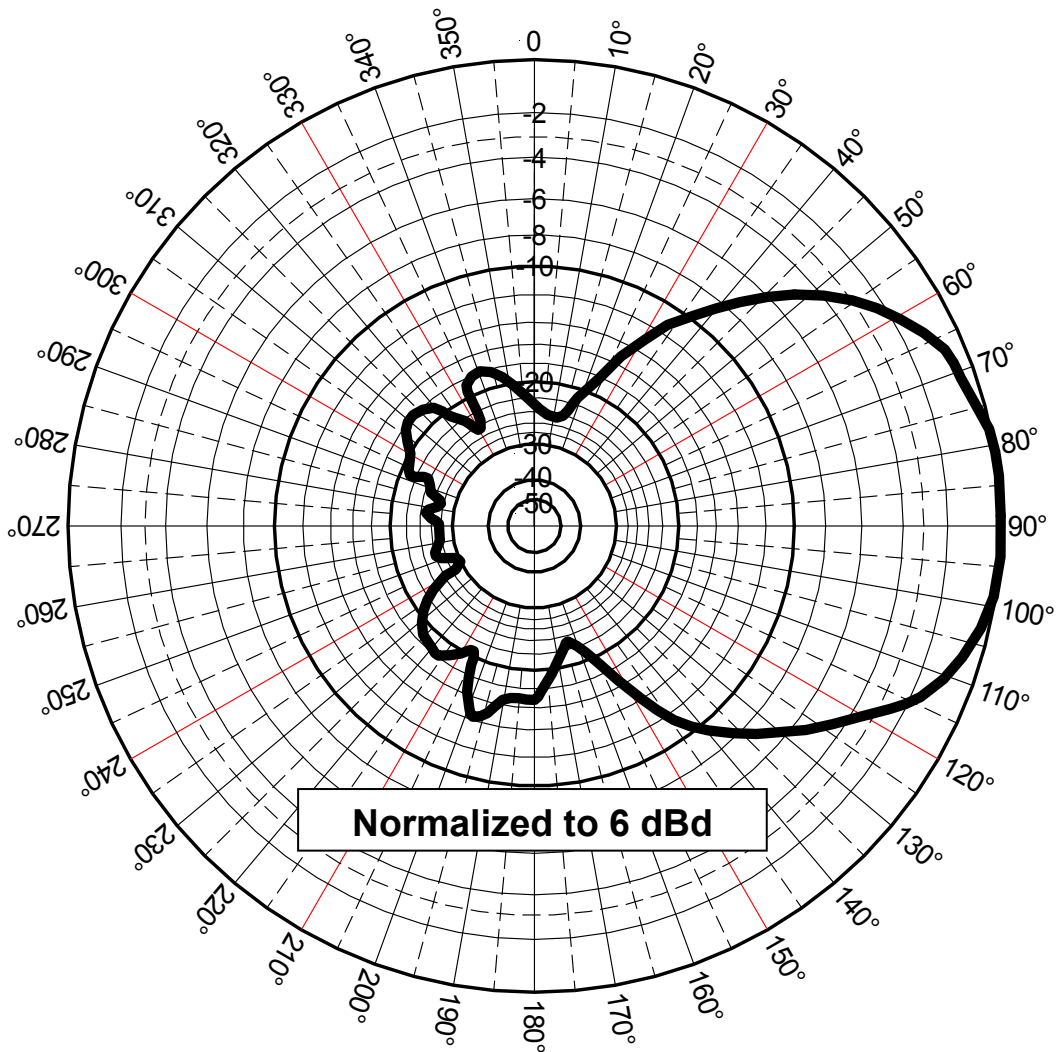

**Vertical-to-Vertical Polarization  
Azimuthal Pattern (X, Y or E-Plane)**

## Product Specification

**TITLE: Y(B)8963 Black or Gold anodized 896-970MHz fully welded  
3 elements 6dBd Directional Yagi**

Part #: **Y(B)8963**  
Memo: **Spec**  
Page: **3 of 5**  
Date: **4/12/2006**

## ANTENNA RADIATION PATTERN

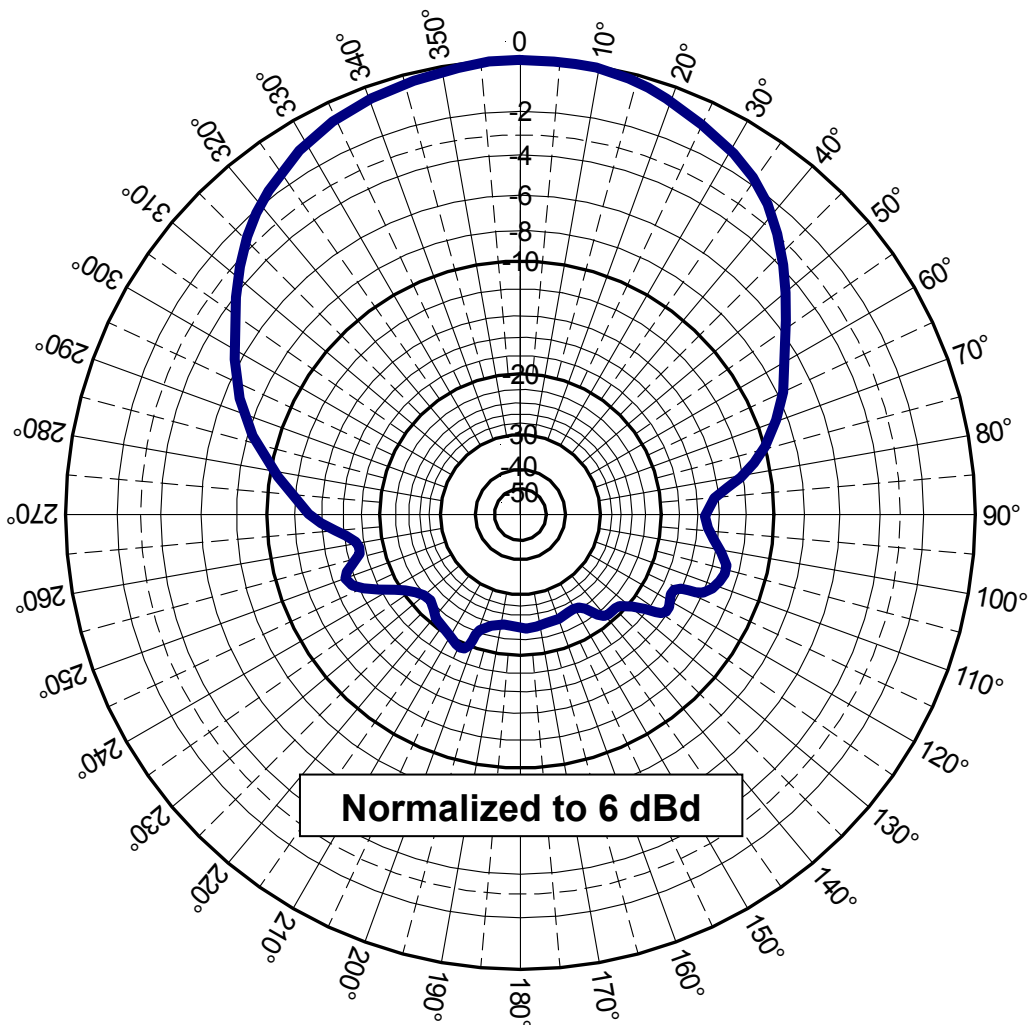

**Horizontal-to-Horizontal Polarization  
Elevation Pattern (Y, Z or H-Plane)**

## Product Specification

**TITLE: Y(B)8963 Black or Gold anodized 896-970MHz fully welded 3 elements 6dBd Directional Yagi**

Part #: **Y(B)8963**  
 Memo: **Spec**  
 Page: **4 of 5**  
 Date: **4/12/2006**

### VSWR of Y8963

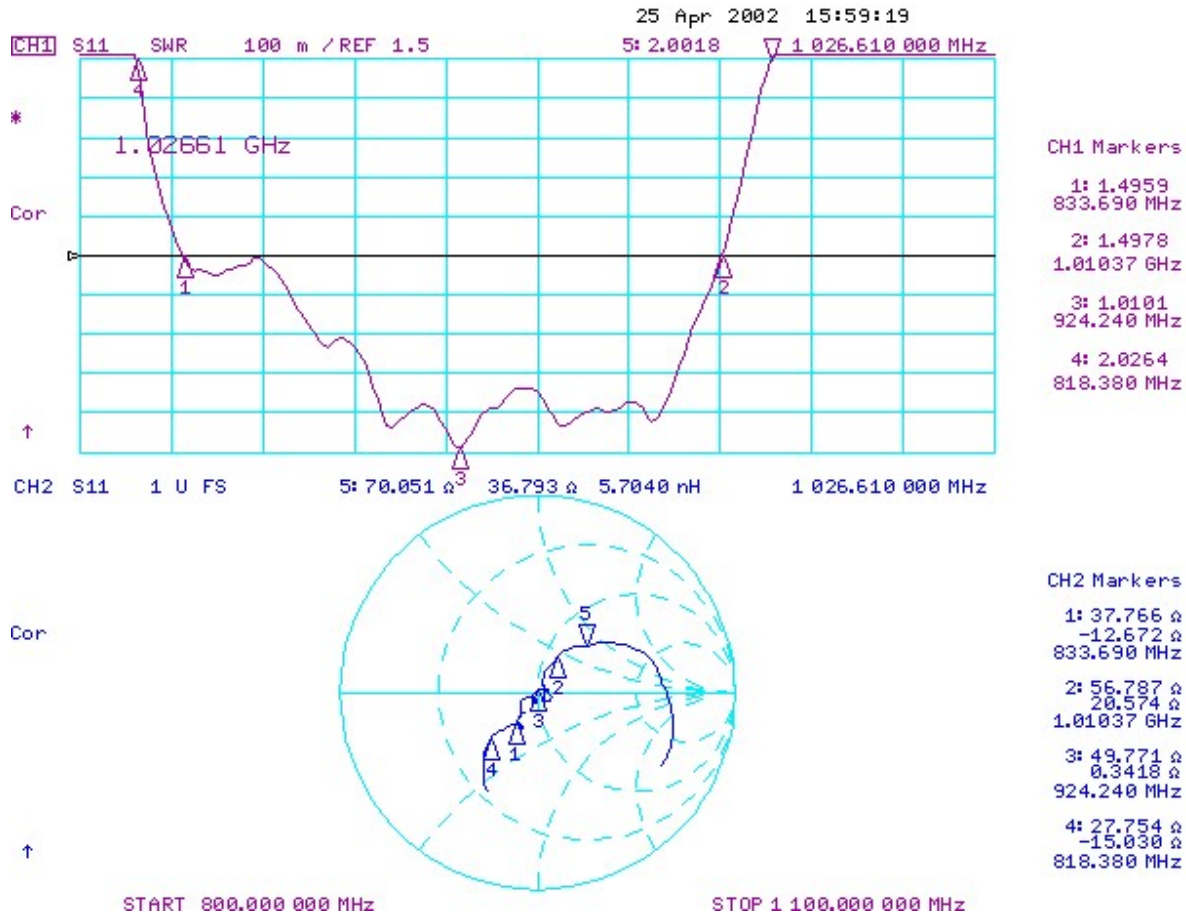

#### Y8963 Typical VSWR sweeps – Primary Specifications

- Marker 1: 1.4959 to 1 @ 833 MHz
- Marker 2: 1.4978 to 1 @ 1010 MHz
- Marker 3: 1.0101 to 1 @ 924 MHz

#### Y8963 Typical VSWR sweeps – Secondary Specifications

- Marker 4: 2.0264 to 1 @ 818 MHz
  - Marker 5: 2.0018 to 1 @ 1026 MHz
- 12/19/2002

## Product Specification

**TITLE: Y(B)8963 Black or Gold anodized 896-970MHz fully welded  
3 elements 6dBd Directional Yagi**

Part #: **Y(B)8963**  
Memo: **Spec**  
Page: **5 of 5**  
Date: **4/12/2006**

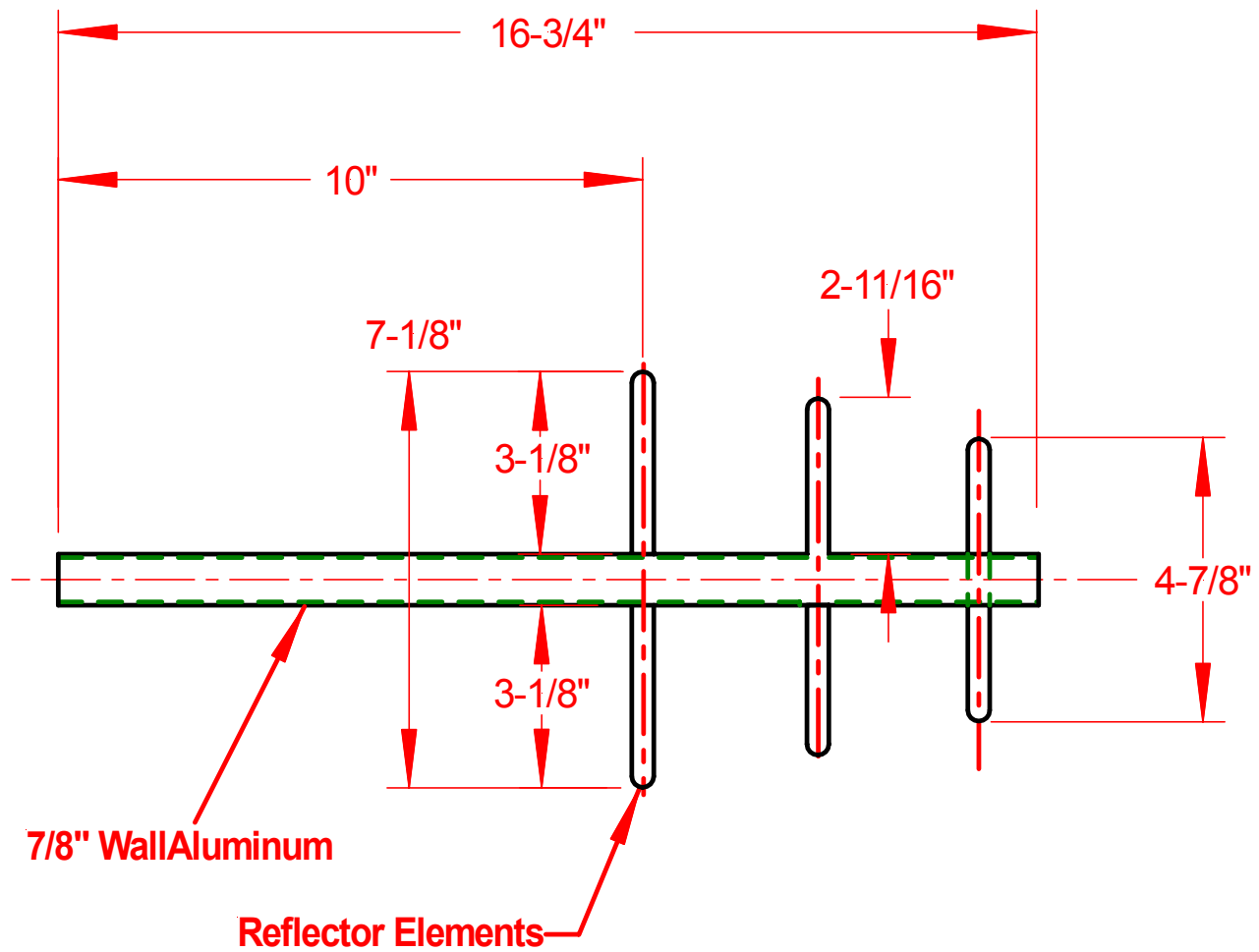

Form factor for Y8963.