

INSTRUCTION SHEET



FC5A Series

This sheet provides brief operating instructions of the MicroSmart programmable controller. For details, see the MicroSmart User's Manual.

FC5A-C10R2, FC5A-C16R2, FC5A-C24R2 (AC power supply)
FC5A-C10R2C, FC5A-C16R2C, FC5A-C24R2C (DC power supply)

Name & Function

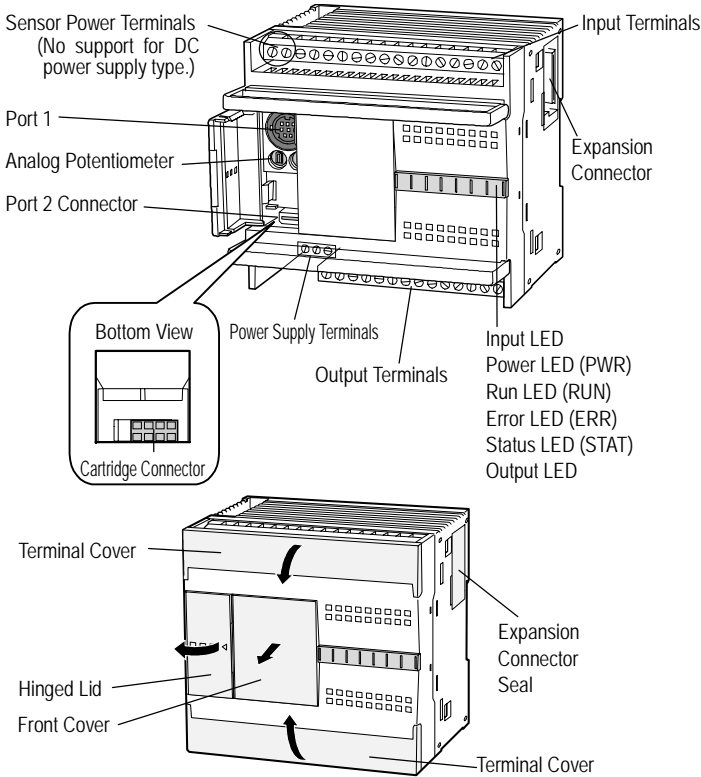

Assembling Modules

Remove the expansion connector Seal from the 24-I/O type CPU module. With the expansion connectors aligned correctly, press the CPU module and I/O module together, and push in the unlatch button to attach the modules together firmly.

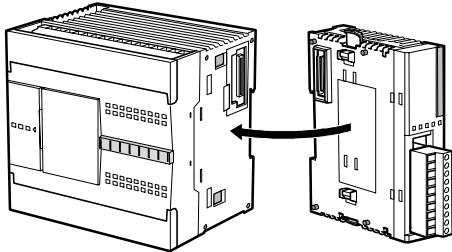

Note: I/O modules cannot be mounted on the 10- and 16-I/O type CPU modules.

Mounting Modules

[DIN Rail Mounting]

Use a 35-mm-wide DIN rail and BNL6 mounting clips to secure the modules.

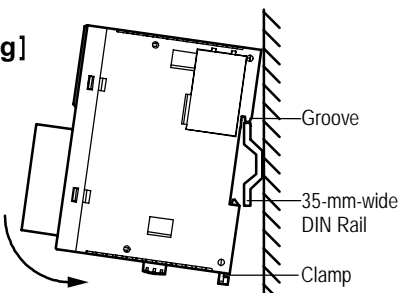

[Direct Mounting]

Use M4 mounting screws (6 mm or 8 mm long).

FC5A-C24R2, -C24R2C

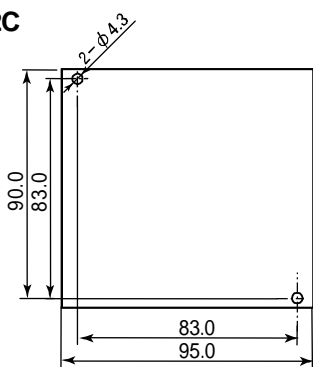

FC5A-C10R2, -C16R2, and -C10R2C, -C16R2C

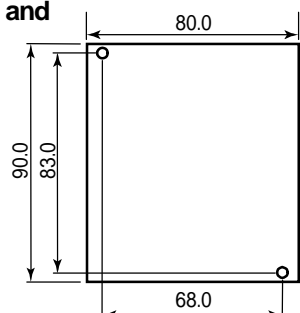

Installation in Control Panel & Mounting Direction

When installing the MicroSmart in a control panel, take the convenience of operation and maintenance, and resistance against environments into consideration.

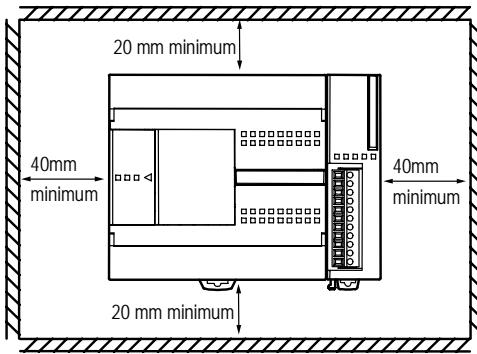

Correct Mounting Direction (at 55 °C or below)

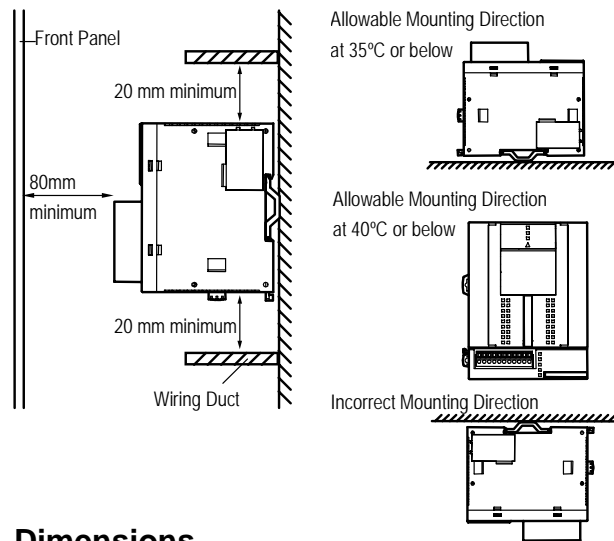

Dimensions

FC5A-C24R2, C24R2C

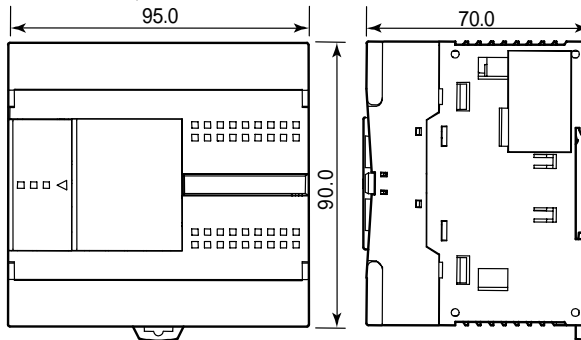

FC5A-C10R2, -C16R2, and -C10R2C -C16R2C

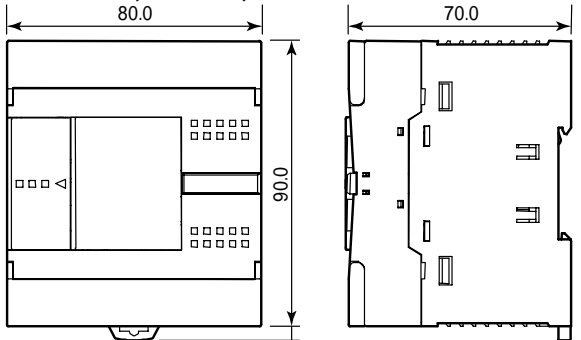

* 8.5 mm when the clamp is pulled out.

Dimensions in mm.

Wiring

DC Sink Input Wiring DC Source Input Wiring

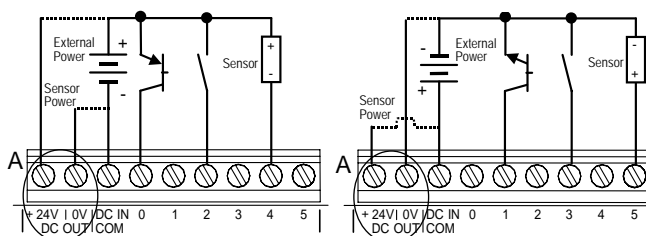

AC power supply type: Support of sensor power which is A-section of above figure is able to use instead of external power. DC power supply type: No support of sensor power. Therefore external power is required.

DC Power Wiring

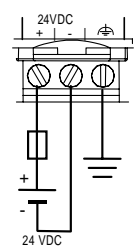

AC Power Wiring

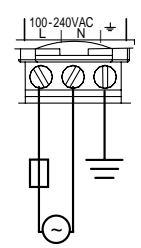

Relay Output Wiring

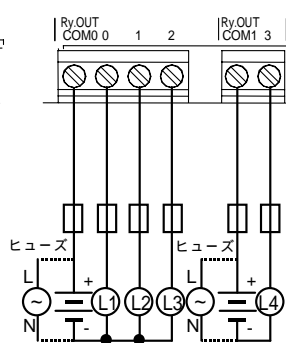

Applicable Ferrule Dimensions (mm)

To crimp the ferrules shown below, use a special crimping tool (CRIMPFOX ZA 3).

For 1-cable connection For 2-cable connection

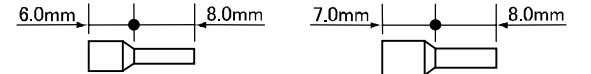

(AI 1-8 RD, AI 1.5-8 BK) (AI-TWIN 2 × 0.75-8 GY)

() indicates the Type No. of Phoenix Contact.

Recommended Screwdriver

When wiring the Phoenix Contact terminal block, use the recommended screwdriver.

(Phoenix Contact Type No.: SZS 0.6×3.5)

SAFETY NOTE

Special expertise is required to use the MicroSmart.

- Read this instruction sheet and the user's manual to make sure of correct operation before starting installation, wiring, operation, maintenance, and inspection of the MicroSmart. Keep this instruction sheet at the end user.
- All MicroSmart modules are manufactured under IDEC's rigorous quality control system, but users must add a backup or failsafe provision to the control system using the MicroSmart in applications where heavy damage or personal injury may be caused in case the MicroSmart should fail.
- Install the MicroSmart according to instructions described in this instruction sheet and the user's manual. Improper installation will result in falling, failure, or malfunction of the MicroSmart.
- Make sure that the operating conditions are as described in the user's manual. If you are uncertain about the specifications, contact IDEC in advance.
- In this instruction sheet, safety precautions are categorized in order of importance to Warning and Caution:

WARNING

(Warning notices are used to emphasize that improper operation may cause severe personal injury or death.)

- Turn power off to the MicroSmart before starting installation, removal, wiring, maintenance, and inspection on the MicroSmart.
- Failure to turn power off may cause electrical shocks or fire hazard. Emergency stop and interlocking circuits must be configured outside the MicroSmart. If such a circuit is configured inside the MicroSmart, failure of the MicroSmart may cause disorder of the control system, damage, or accidents.
- This equipment is suitable for use in Class I, Division 2, Groups A, B, C, D or non-hazardous locations only.
- Warning - Explosion Hazard - Substitution of components may impair suitability for Class I, Division 2.
- Warning - Explosion Hazard - Do not disconnect equipment unless power has been switched off or the area is known to be non-hazardous.

CAUTION

(Caution notices are used where inattention might cause personal injury or damage to equipment.)

- The MicroSmart is designed for installation in equipment. Do not install the MicroSmart outside equipment.
- Install the MicroSmart in environments described in the user's manual. If the MicroSmart is used in places where the MicroSmart is subjected to high-temperature, high-humidity, condensation, corrosive gases, excessive vibrations, and excessive shocks, then electrical shocks, fire hazard, or malfunction will result.
- The environment for using the MicroSmart is "Pollution degree 2."
- Prevent metal fragments and pieces of wire from dropping inside the MicroSmart housing. Ingress of such fragments and chips may cause fire hazard, damage, or malfunction.
- Use wires of a proper size to meet voltage and current requirements. Tighten terminal screws to a proper tightening torque of 0.5 N·m.
- Use an IEC60127-approved fuse on the power line and output circuit to meet voltage and current requirements. (Recommended fuse: Littelfuse 5x20mm slow-blow type 218000 series/Type T) This is required when exporting equipment containing MicroSmart to Europe.
- Use an EU-approved circuit breaker. This is required when exporting equipment containing MicroSmart to Europe.
- If relays or transistors in the MicroSmart output modules should fail, outputs may remain on or off. For output signals which may cause heavy accidents, provide a monitor circuit outside of the MicroSmart.
- Use the sensor power supply only for supplying power to sensors connected to the MicroSmart.
- Do not disassemble, repair, or modify the MicroSmart modules.

