

ESP41x

RS-232/422/485 to Ethernet Serial Server

- ✓ Easy to Use and Configure – Software Included
- ✓ Data Rates up to 230 Kbps
- ✓ 1, 2, or 4 Port Versions Available
- ✓ Supports RS-232, RS-422, and 2-Wire/4-Wire RS-485
- ✓ Supports Virtual COM Port, Direct IP, and Paired Modes



These commercial grade serial to Ethernet converters allow you to control serial devices located virtually anywhere, through a TCP/IP or UDP/IP Ethernet connection. They are equipped with one, two or four serial port connections on one side, and a 10/100 Mbps Ethernet connection on the other side, allowing you to easily connect legacy or new serial devices to your Ethernet network. Installation and configuration is quick and easy with the VLinX™ Manager Software provided on CD ROM. The software is compatible with Window 2000, 2003 Server, XP, and Vista. It is powered from a 12 VDC power supply (included with the unit). Power supply options for US, UK, and EU are available. With three operating modes to select from; Virtual COM Port, Straight IP, & Paired, you can easily network enable any RS-232/422/485 device. RS-485 supports both 2-Wire and 4-Wire modes.

- IEEE 802.3U 10/100BaseT, auto-detecting
- TCP Server, TCP Client, or UDP
- Direct IP, Paired, or Virtual COM
- TCP Probe – Automatically restores connection in Virtual COM mode
- Data rates up to 230 Kbps
- Power Supply Included

Virtual COM Port

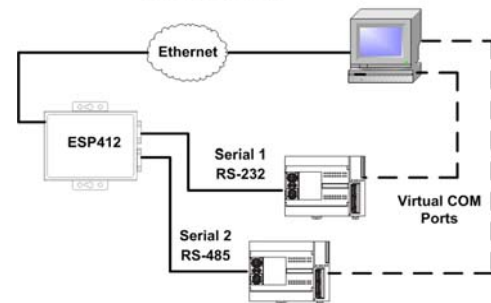

Paired Mode

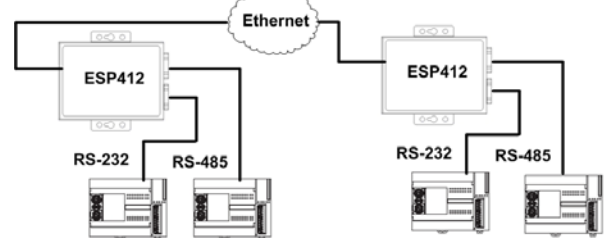

Direct IP

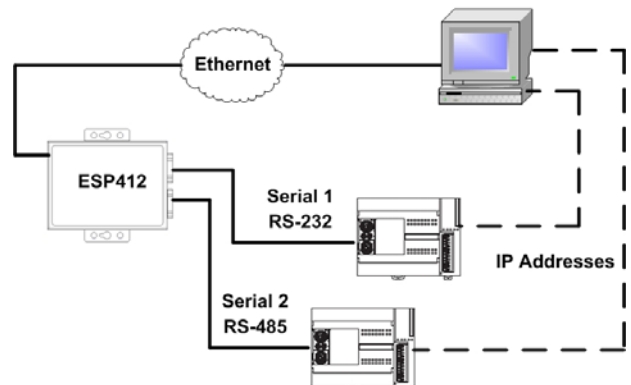

Specifications

Serial Interface		Power	
Connector ESP411	DB9 Male (DTE), Terminal Block	ESP41x	Power Adapter Included
Connectors ESP412	2 DB9 Male (DTE)		12 VDC, US Plug
Connectors ESP414	4 DB9 Male (DTE)		Input, 100 to 240 VAC, 47 to 63 Hz
Protocol	RS-232, RS-422, RS-485 2-Wire, RS-485 4-Wire		North American Plug
Data Rate	Up to 230.4 Kbps		Output 12 VDC, 0.5 mm Barrel
Flow Control	None, RTS/CTS or XON/XOFF	ESP41x-EU	Plug, center positive
		ESP41x-UK	Same except EU Plug
			Same except UK Plug
Ethernet		Regulatory Approvals	
Standard	IEEE 802.3u, 10/100 BaseT	FCC	Part 15 Class A
Protocols	Auto detecting, Auto MDI/MDIX TCP, UDP, IP, ARP, ICMP, HTTP, Telnet, DHCP	CE	DoC Available for Download
Communication Type	TCP Server/Client, UDP UDP Multicast Straight IP, Paired, Virtual COM Port		
Security	Password, IP Address Filtering	Ordering Information	
Operating System	Windows 2000, 2003 Server XP and Vista	ESP411	RS-232/422/485 MEI North American
		ESP411-EU	RS-232/422/485 MEI EU
		ESP411-UK	RS-232/422/485 MEI UK
		ESP412	RS-232/422/485 MEI North American
		ESP412-EU	RS-232/422/485 MEI EU
		ESP412-UK	RS-232/422/485 MEI UK
		ESP414	RS-232/422/485 MEI North American
		ESP414-EU	RS-232/422/485 MEI EU
		ESP414-UK	RS-232/422/485 MEI UK
Mechanical		Accessory Items (not included)	
Enclosure	IP 30, Metal	C5UMB3FBG	UTP Ethernet Cable, 3 ft
Dimensions ESP411/412	4.5 x 4.3 x 1 in (114 x 108 x 23 mm)	9PAMF6	RS-232 Cable, DB9 M / DB9 F, 6 ft
Dimensions ESP414	4.2 x 7.3 x 1 in (107 x 185 x 23 mm)	232NM9FF6	RS-232 Null Modem Cable, DB9F / DB9 F 6 ft
Op Temp	0 to 131 F (0 to 55 C)	DRAD35	DIN Rail Mounting Kit
Storage Temp	-4 to 185 F (-20 to 85 C)		
Op Humidity	0 to 95% Non-condensing		
MTBF	193000 hours		
MTBF Calc. Method	Parts Count Reliability Prediction		

Dimensional Diagram – ESP411 / ESP412
 Units are in MM

