



Models: EMD-10FST, EMD-100FST, EMD-100FSC
B&B Electronics' IASolutions
Ethernet Media Converters

The B&B IASolutions line of Industrial Ethernet Media Converters offers a solution for those industrial applications requiring a trouble-free, robust process of converting between copper and fiber media. Appearing as transparent devices, media converters are a cost-effective approach for adding fiber to a network. B&B Electronics media converters are available in three models and all support full- or half-duplex operation. The EMD-10FST operates at 10 Mbps and meets the signaling requirements for 10BASE-T and 10BASE-FL. Two models pass 100-Mbps data between 100BASE-TX and 100BASE-FX segments: the EMD-100FST makes the fiber optic connection via ST-style connectors, whereas the EMD-100FSC does so via SC-style connectors. Two front-panel DIP switches set the operational mode—full-duplex, half-duplex or transparent.

The data rate on the fiber cable is matched automatically, but a connection to the copper partner is established only if the partner meets the connection requirements. In full-duplex mode, all models can span 2 km with 62.5/125 μm fiber cables. If the 100 Mbps devices operate in half-duplex mode with fiber length limited to 412 m by the collision domain. The 10 Mbps model can operate with 2 km fiber segments in either half- or full-duplex mode. The copper link has no required minimum distance, but the fiber link's minimum distance is 2 m.

In transparent mode, the copper segments of two media converters linked with fiber will auto-negotiate as if the fiber link were not there. This auto-negotiation will determine the data rate and whether the link will operate in full- or half duplex mode. Transparent mode will allow a fiber optic link between two 100BASE-TX or 10BASE-T devices as well as between a 10BASE-T device and a 100BASE-TX device. In the latter case, the link will operate at 10 Mbps.

Several LEDs are provided for convenient front panel diagnostics. The Power LED (P) glows green when power is applied. Each port has two LEDs. The Port Activity LED (A) flashes green as data is transferred and the Link LED (L) indicates the data rate by color: green for 100 Mbps and yellow for 10 Mbps.

All units mount on TS-32 or TS-35 DIN-rail, operate from a wide range of low-voltage AC or DC power and offer redundant power connections. The B&B Electronics' IASolutions media converter series is intended for Industrial Ethernet applications and complies with the EMC standards for immunity and emissions to withstand the rigors of harsh industrial environments.

Benefits:

- Compact size
- 10BASE-T/10BASE-FL or 100BASE-TX/100BASE-FX compliant
- Built-in uplink provision
- Auto-negotiated data rate and flow control on twisted-pair ports
- DIN-rail mountable
- Low-voltage AC or DC operation
- Full or half duplex
- Provision for redundant power sources
- Activity, link and power LEDs

Applications:

- Ethernet I/O
- Interconnection of Ethernet PLCs, operator interface, motion control
- Environmental control
- Test and measurement
- Process control
- Remote data acquisition
- Communications gateway
- Machine monitoring

International Headquarters:

B&B Electronics Mfg. Co. 707 Dayton Road P.O. Box 1040 Ottawa, IL 61350 USA
 815-433-5100 Fax 433-5104 www.bb-elec.com orders@bb-elec.com support@bb-elec.com

B&B Electronics Ltd Westlink Commercial Park Oranmore Co. Galway Ireland
 +353 91 792444 Fax +353 91 792445 www.bb-europe.com orders@bb-elec.com support@bb-europe.com

Specifications:

- | | | |
|-------------------------------|--|------------|
| Electrical: | DC: | AC: |
| • Input voltage | 10–36 Volts | 8–24 Volts |
| • Input power (max) | 4 Watts | 4 VA |
| • Input frequency | N/A | 47–63 Hz |
| Environmental: | | |
| • Operating temperature | 0 to +60°C (-32 to 140°F) | |
| • Storage temperature | -40 to +85°C (-40 to 185°F) | |
| Mounting: | DIN-rail TS-35 or TS-32 | |
| Functional: | | |
| • Compliance | ANSI/IEEE 802.3 | |
| • Data rate | 10/100 Mbps | |
| • Signaling | 10BASE-T/10BASE-FL or 100BASE-TX/100BASE-FX | |
| • Fiber wavelength | 10BASE-FL—850 nm
100BASE-FX—1300 nm | |
| • Port connectors | Copper: Shielded RJ-45
Fiber: ST or SC | |
| • Segment length (max) | Copper: 100 m, Fiber: 2 km | |
| • LED indicators ¹ | POWER—green, ACTIVITY—green
LINK/DATA RATE—green/yellow | |
| • Flow control | Half Duplex—back pressure
Full Duplex—IEEE 802.3x | |

¹ ACTIVITY and LINK/DATA RATE LEDs exist for each port.

Regulatory Compliance Standards:

- Regulatory Compliance:**
 - CE Mark, FCC Part 15 Class A, UL 508 Listed, Industrial Control Equipment
- | Standard: | Test Method: | Description: | Test Levels: |
|------------------|---------------------|------------------------------|---------------------------------------|
| • EN 55024 | EN 61000-4-2 | Electrostatic Discharge | 6 kV Contact & 4 kV Air |
| • EN 55024 | EN 61000-4-3 | Radiated Immunity | 10 v/m 80 MHz to 1 GHz |
| • EN 55024 | EN 61000-4-4 | Fast Transient Burst | 1 kV Clamp & 2 kV Direct |
| • EN 55024 | EN 61000-4-5 | Voltage Surge | 1 kV L to L & 2 kV L to Earth |
| • EN 55024 | EN 61000-4-6 | Conducted Immunity | 10 Volts (rms) |
| • EN 55024 | EN 61000-4-11 | Voltage Dips & Interruptions | 1 line cycle to 1 & 5 sec. @ 100% dip |
| • EN 55022 | CISPR 22 | Radiated Emissions | Class A |
| • EN 55022 | CISPR 22 | Conducted Emissions | Class B |

MDI-X₂ 10BASE-T/100BASE-TX

- RJ-45: Usage:**

1	TD+
2	TD-
3	RD+
4	Not Used
5	Not Used
6	RD-
7	Not Used
8	Not Used
- ² Units have both an MDI and an MDI-Xport.

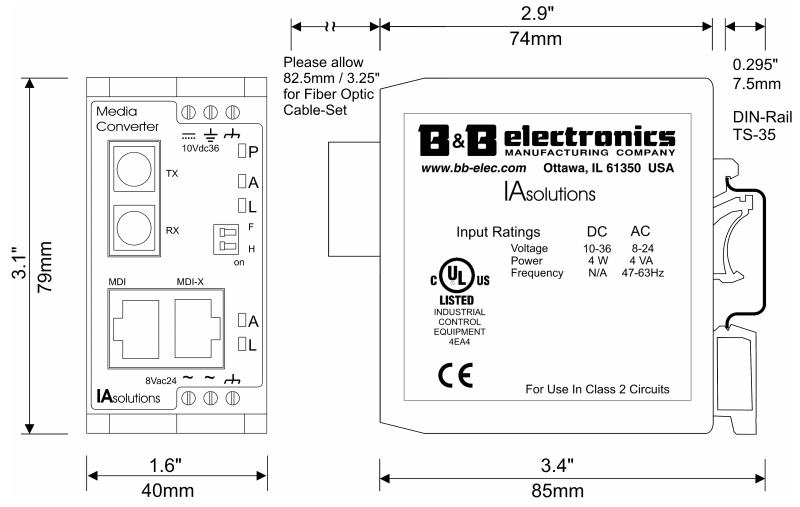
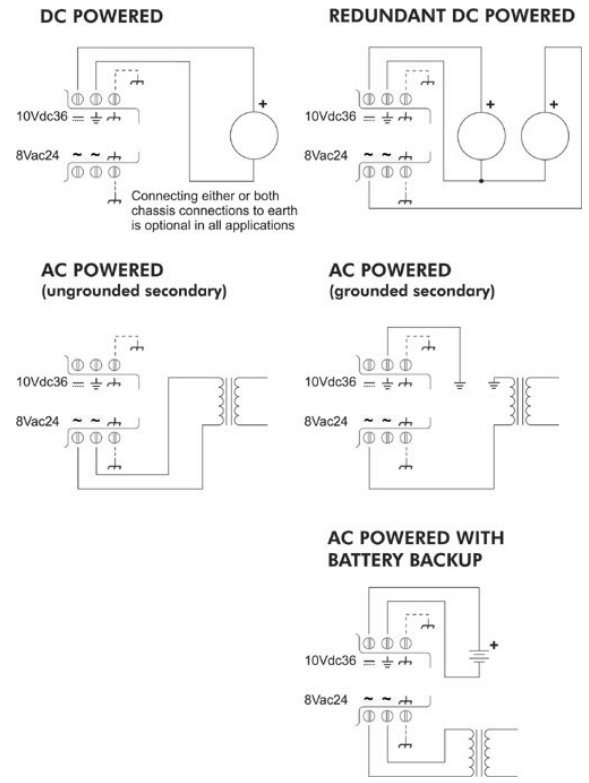

Dimensional Diagram of Media Converters (Model EMD-100FSC shown)

International Headquarters:

B&B Electronics Mfg. Co. 707 Dayton Road P.O. Box 1040 Ottawa, IL 61350 USA
815-433-5100 Fax 433-5104 www.bb-elec.com orders@bb-elec.com support@bb-elec.com

B&B Electronics Ltd Westlink Commercial Park Oranmore Co. Galway Ireland
+353 91 792444 Fax +353 91 792445 www.bb-europe.com orders@bb-elec.com support@bb-europe.com