

Serial Line Analyzer Adapter

Model 485SLAA

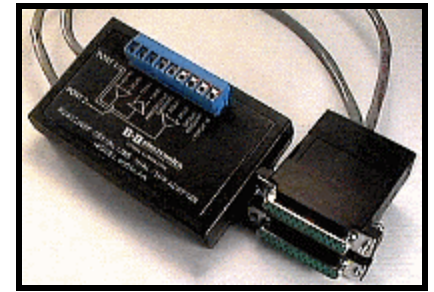

GENERAL

The Model 485SLAA Serial Line Analyzer Adapter permits computers with serial line analyzer software to test RS-422 and RS-485 networks. The adapter can be used with four-wire full-duplex RS-422/485 networks or two-wire half-duplex RS-485 networks. Figure 1 is a block diagram of the adapter.

SOFTWARE COMPATIBILITY

The Model 485SLAA can be used with any serial line analyzer software on any computer that uses two serial ports to monitor full-duplex communications.

The adapter converts two balanced RS-422/485 data lines to RS-232 for input to two ports. It converts one output line (Port 1) from RS-232 to RS-485 for transmitting data to a network.

CONNECTION TO AN RS-422 FOUR-WIRE NETWORK

Figure 2 illustrates how to connect the 485SLAA to a RS-422 four-wire network. Do not connect the transmit driver to the network unless you are transmitting data to the network. This connection will cause the adapter to use more power. If data is transmitted to the network, you must select which part of the network is to be connected. You must make RTS high on Port 1 before you transmit data to the network. You must make RTS low on Port 1 when you have finished transmitting data to the network.

CONNECTION TO AN RS-485 TWO-WIRE NETWORK

Figure 3 illustrates how to connect the 485SLAA to a two-wire RS-485 network. Do not connect the transmit driver to the network unless you are transmitting data to the network. This connection will cause the adapter to use more power. You must make RTS high on Port 1 before you transmit data to the network. You must make RTS low on Port 1 when you have finished transmitting data to the network. If you are only monitoring the network, disconnect the transmit driver and leave RTS in the active (high) state.

POWERING THE 485SLAA FROM SERIAL COMPUTER PORTS

Power is obtained from the computer ports connected to the 485SLAA. It is important that at least two handshake lines be left in the high or active state at all times. If you are using Breakout II software, you can force all handshake lines high by following these two steps.

- 1) Select Port 2 as the primary port and configure the computer in the "Interactive" mode. Now set both DTR and RTS high on Port 2.
- 2) Select Port 1 as the primary port and configure the computer to the "Interactive" mode. Now set both DTR and RTS high on Port 1.
- 3) Change the computer to the desired analysis mode, either "Monitor" or "Interactive". If you select the "Monitor" mode the software will not change the state of DTR or RTS on Port 2 or Port 1. If you are in the "Interactive" mode and you are operating with Port 1 as the Primary port, you can manually change the state of DTR and RTS. Since DTR is only used for power, leave it in the high or active state. You can now change the state of RTS to what is required to send data to your RS-485 network.

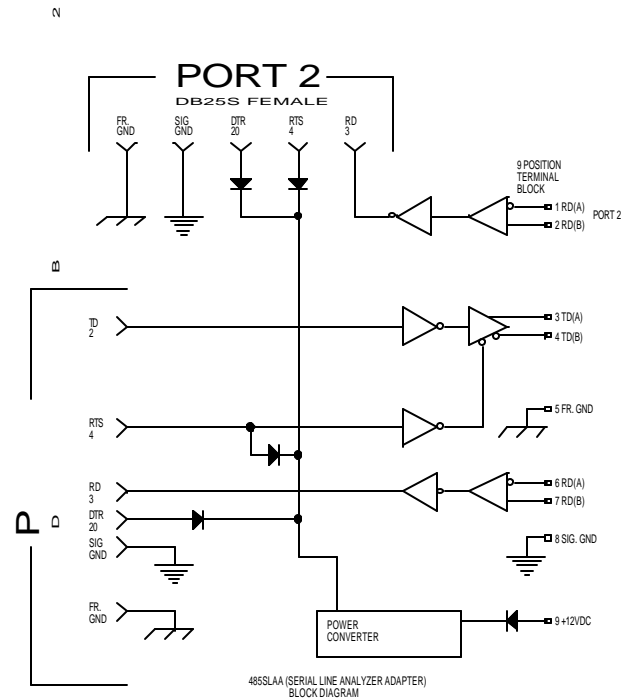

Figure 1

This product designed and manufactured in USA of domestic and imported parts by

B&B Electronics Mfg. Co.
 707 Dayton Road - P.O. Box 1040 - Ottawa, IL 61350 USA
 Phone: (815) 433-5100 - Fax: (815) 433-5105
 Home Page: www.bb-elec.com
 Sales e-mail: sales@bb-elec.com - Fax: (815) 433-5109
 Technical Support e-mail: support@bb-elec.com - Fax: (815) 433-5104

B&B Electronics Ltd
 Westlink Commercial Park - Oranmore, Co. Galway - Ireland
 Phone: (353) 91 792444 - Fax: (353) 91 792445
 Home Page: www.bb-europe.com
 Sales e-mail: sales@bb-europe.com
 Technical Support e-mail: support@bb-europe.com

POWERING THE 485SLAA WHEN USING A LOW POWER RS-562 PORT

An RS-562 port will supply only about 3 volts and will not have enough power for the adapter. When using this type of port, connect an external +12 VDC power supply to the terminal block marked "+12VDC IN" (9). Connect the ground connection of the power supply to the terminal marked "SIGNAL GROUND" (8).

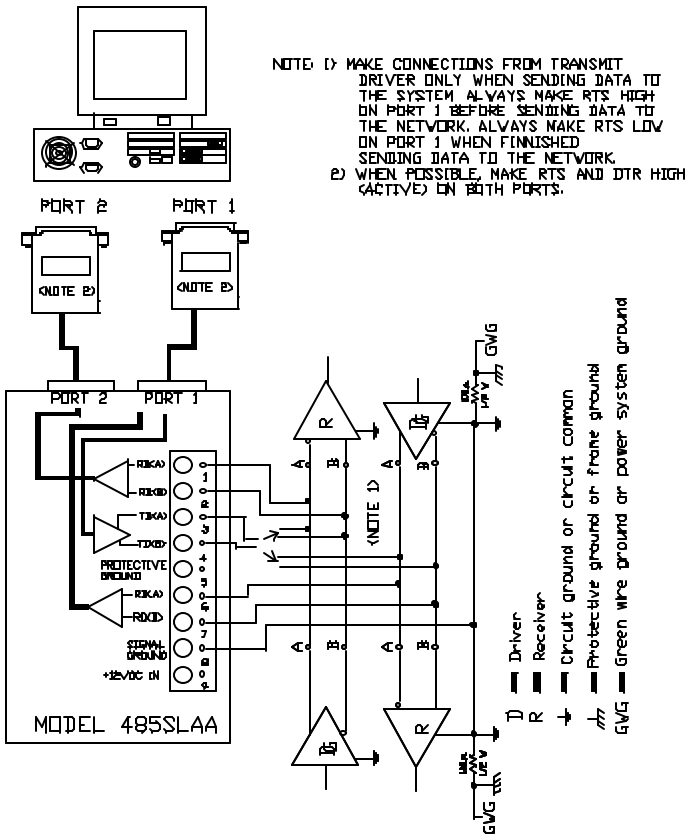

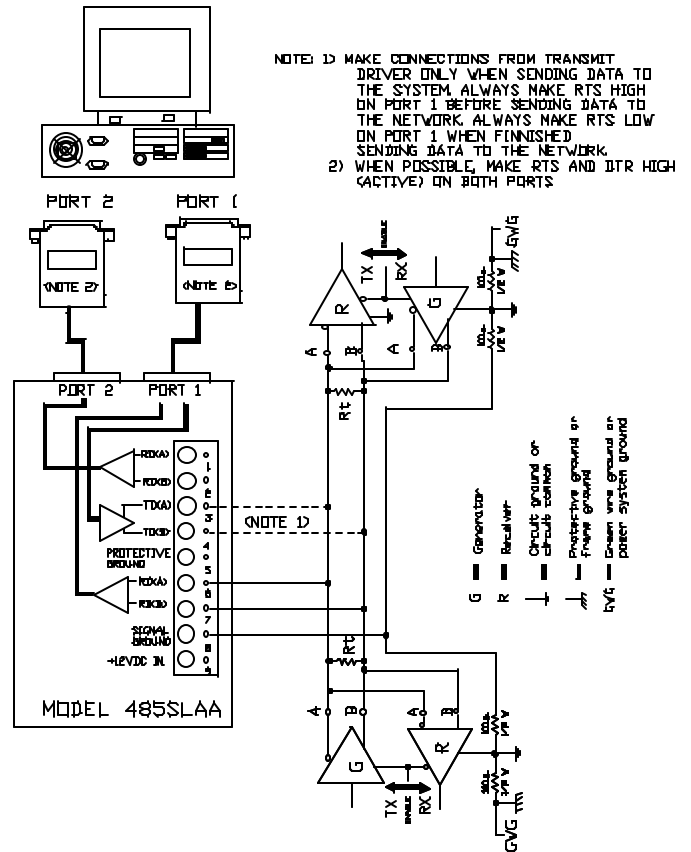

CONNECTION TO FOUR WIRE RS-422/RS-485 SYSTEM

Figure 2



CONNECTION TO TWO WIRE RS-485 SYSTEM

Figure 3

DECLARATION OF CONFORMITY	
Manufacturer's Name:	B&B Electronics Manufacturing Company
Manufacturer's Address:	P.O. Box 1040 707 Dayton Road Ottawa, IL 61350 USA
Model Numbers:	485SLAA
Description:	Serial Line Analyzer Adapter
Type:	Light industrial ITE equipment
Application of Council Directive:	89/336/EEC
Standards:	EN 50082-1 (IEC 801-2, IEC 801-3, IEC 801-4) EN 50081-1 (EN 55022, IEC 1000-4-2) EN 61000 (-4-3, -4-4) ENV 50204
 Michael J. Fahrion, Director of Engineering	
	

© B&B Electronics – Revised September 1999

This product designed and manufactured in USA of domestic and imported parts by

B&B Electronics Mfg. Co.
 707 Dayton Road - P.O. Box 1040 - Ottawa, IL 61350 USA
 Phone: (815) 433-5100 - Fax: (815) 433-5105
 Home Page: www.bb-elec.com
 Sales e-mail: sales@bb-elec.com - Fax: (815) 433-5109
 Technical Support e-mail: support@bb-elec.com - Fax: (815) 433-5104

B&B Electronics Ltd
 Westlink Commercial Park - Oranmore, Co. Galway - Ireland
 Phone: (353) 91 792444 - Fax: (353) 91 792445
 Home Page: www.bb-europe.com
 Sales e-mail: sales@bb-europe.com
 Technical Support e-mail: support@bb-europe.com

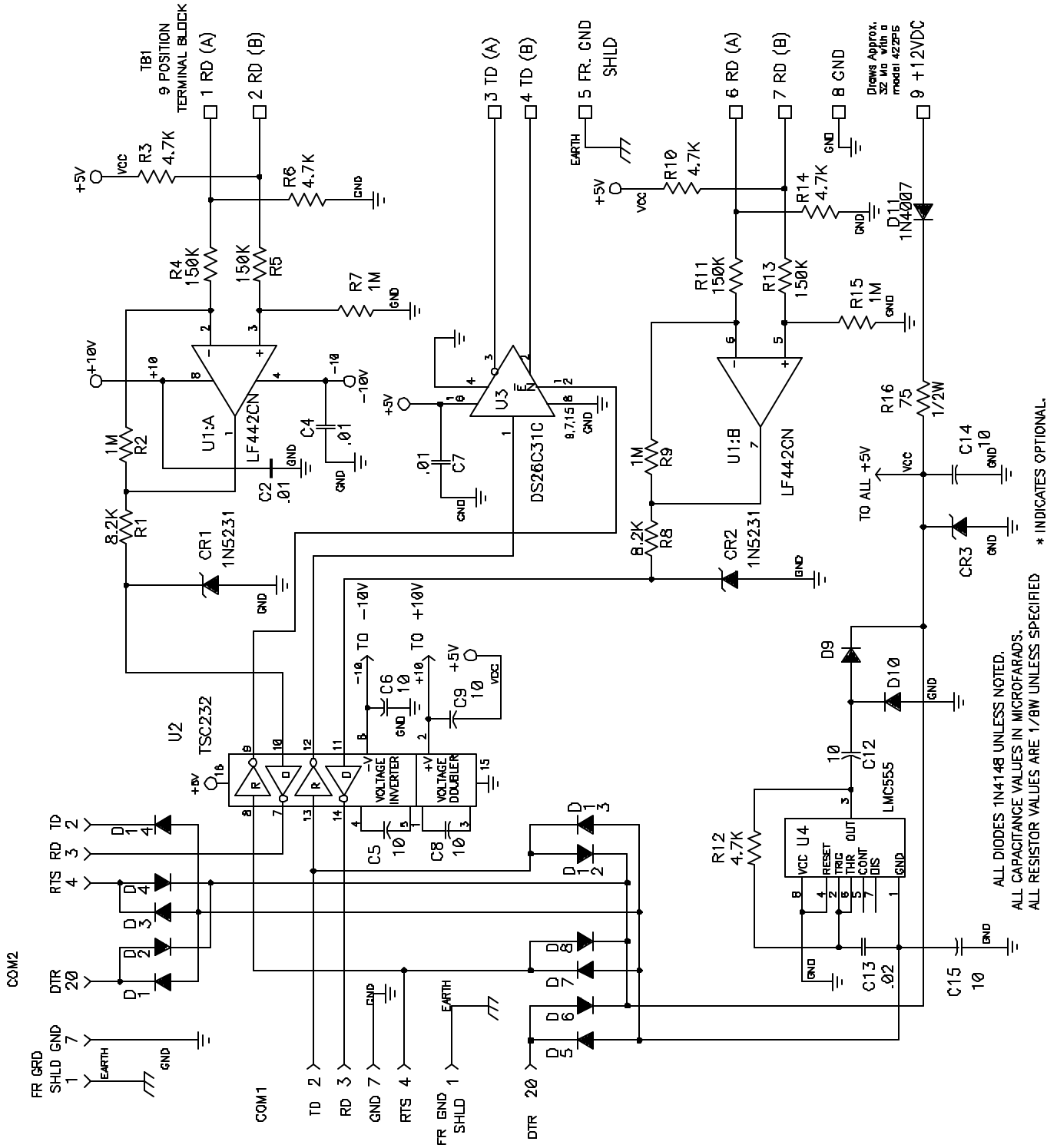

ALL DIODES 1N4148 UNLESS NOTED.
 ALL CAPACITANCE VALUES IN MICROFARADS.
 ALL RESISTOR VALUES ARE 1/8W UNLESS SPECIFIED * INDICATES OPTIONAL.

© B&B Electronics – Revised September 1999

This product designed and manufactured in USA of domestic and imported parts by

B & B Electronics Mfg. Co.

707 Dayton Road - P.O. Box 1040 - Ottawa, IL 61350 USA

Phone: (815) 433-5100 - Fax: (815) 433-5105

Home Page: www.bb-elec.com

Sales e-mail: sales@bb-elec.com - Fax: (815) 433-5109

Technical Support e-mail: support@bb-elec.com - Fax: (815) 433-5104

B & B Electronics Ltd

Westlink Commercial Park - Oranmore, Co. Galway - Ireland

Phone: (353) 91 792444 - Fax: (353) 91 792445

Home Page: www.bb-europe.com

Sales e-mail: sales@bb-europe.com

Technical Support e-mail: support@bb-europe.com