

Model: 485OISPR
Reversed RS-232 to RS-485
Optically Isolated Converter

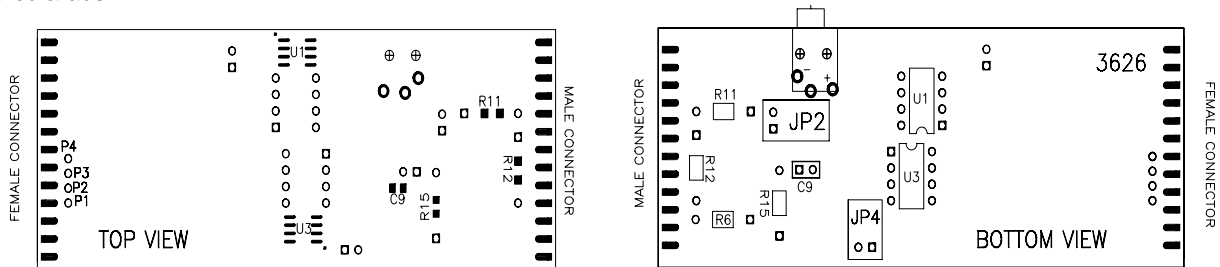

The Model 485OISPR converts unbalanced, full or half-duplex RS-232 signals to optically isolated, balanced, full or half-duplex RS-422 or RS-485 signals. RS-485 is an enhanced version of the RS-422 Standard. It allows multiple drivers and receivers on a two-wire system.

The 485OISPR is an RS-232 to RS-422 converter with optical isolation and surge protection. The opto-isolators are rated up to 2500 VAC. The surge suppressors are 7.5 V, bi-directional avalanche breakdown devices, with a 500W peak power dissipation and 1 picosecond (theoretical) clamping time. The surge suppressors add a maximum of 6000 picofarads.



The RS-232 port has a female DB-25 connector with pins 2 (TD), 3 (RD), and 7 (Signal Ground) supported. Pins 4 (RTS) and 20 (DTR) are used to power the RS-232 side of the converter. If your port cannot supply this power, a power supply can be connected to the RS-232 pins 25 (+12 VDC) and 12 (ground). The RS-485 DB-25 male connector provides connection for Transmit Data (A) and (B), Receive Data (A) and (B), and Signal Ground. There is a power supply, which plugs into the side of the converter, available from B&B for the RS-485 side of the converter. On the 485 side, power may also be supplied to pins 25 (+12 VDC) and 12 (Ground).

The 485OISPR enables the RS-485 driver by automatic sensing of data on Transmit Data (pin 2) of the RS-232 side. The 485OISPR has two jumpers located inside of the box. One enables either RS-422 or RS-485 mode (JP4). The other (JP2) is used in the two-wire mode, and allows you to prevent data being sent from the RS-232 port from being echoed back to the RS-232 port. See Figure 2.

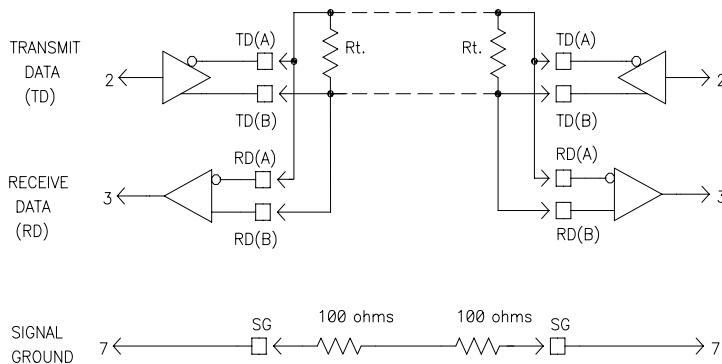

FIGURE 2. INTERCONNECTION DRAWING



International Headquarters: 707 Dayton Road PO Box 1040 Ottawa, IL 61350 USA
815-433-5100 Fax 433-5104 www.bb-elec.com orders@bb-elec.com support@bb-elec.com

European Headquarters: Westlink Commercial Park Oranmore Co. Galway Ireland
+353 91 792444 Fax +353 91 792445 www.bb-europe.com orders@bb-europe.com support@bb-europe.com

There are also two internal components, a resistor (R15) and a capacitor (C9), that control timing. These components are part of the automatic sensing circuit, and affect the baud rate at which the converter can be used in a two-wire setup. These components are factory selected to allow the converter to run at 9600 baud or higher. With these two components, the RS-485 driver will shut off approximately 1ms after the last character has been sent. If you need a baud rate lower than 9600 baud or would like to configure the 485OISPR for a specific baud rate, see Table 1.

Table 1			
COMPONENT REPLACEMENTS FOR CHANGING BAUD RATE TIMEOUTS			
Baud Rate	Time (ms)	Resistor (R15) (ohm)	Capacitor (C9) (mfd)
300	33.3	330k	0.1
600	16.6	160K	0.1
1200	8.33	820K	0.01
2400	4.16	430K	0.01
4800	2.08	200K	0.01
9600	1.04	100K	0.01
19200	.520	56K	0.01
38400	.260	27K	0.01

Up to 32 receivers can be driven by any one RS-485 driver, allowing you to put together large systems with many drop points. If you are using termination resistors, they should be located at opposite ends of the system.

Figure 3 shows how to interconnect two RS-485 converters in a half-duplex system using two wires. The resistors R_t are optional, depending on line length, baud rate, etc. The resistors R_t should be about the impedance of the line used, which is normally about 120 ohms each.

Proper operation of any RS-485 system requires the presence of a return path. The RS-485 Standard recommends that a third wire be used for this. For safety, a 100 ohm, 1/2 watt resistor should be connected between Signal Ground and the "reference wire" at every drop point. While it may be possible to interconnect Signal Grounds directly, this is not recommended due to the danger of circulating currents possibly being present.

No wire type or maximum run length is listed in the RS-485 Standard. However, the RS-422 Standard (which is very similar) recommends number 24 AWG twisted-pair telephone cable with a shunt capacitance of 16 picofarads per foot, and no more than 4000 feet long.

DECLARATION OF CONFORMITY

Manufacturer's Name: B&B Electronics Manufacturing Company
 Manufacturer's Address: P.O. Box 1040
 707 Dayton Road
 Ottawa, IL 61350 USA
 Model Number: 485OISPR
 Type: Light industrial ITE equipment
 Application of Council Directive: 89/336/EEC
 Standards: EN 55022
 EN 61000-6-1
 EN 61000 (-4-2, -4-3, -4-4, -4-5, -4-6, -4-8, -4-11)



Robert M. Paratore, Director of Engineering



International Headquarters: 707 Dayton Road PO Box 1040 Ottawa, IL 61350 USA
 815-433-5100 Fax 433-5104 www.bb-elec.com orders@bb-elec.com support@bb-elec.com

European Headquarters: Westlink Commercial Park Oranmore Co. Galway Ireland
 +353 91 792444 Fax +353 91 792445 www.bb-europe.com orders@bb-europe.com support@bb-europe.com

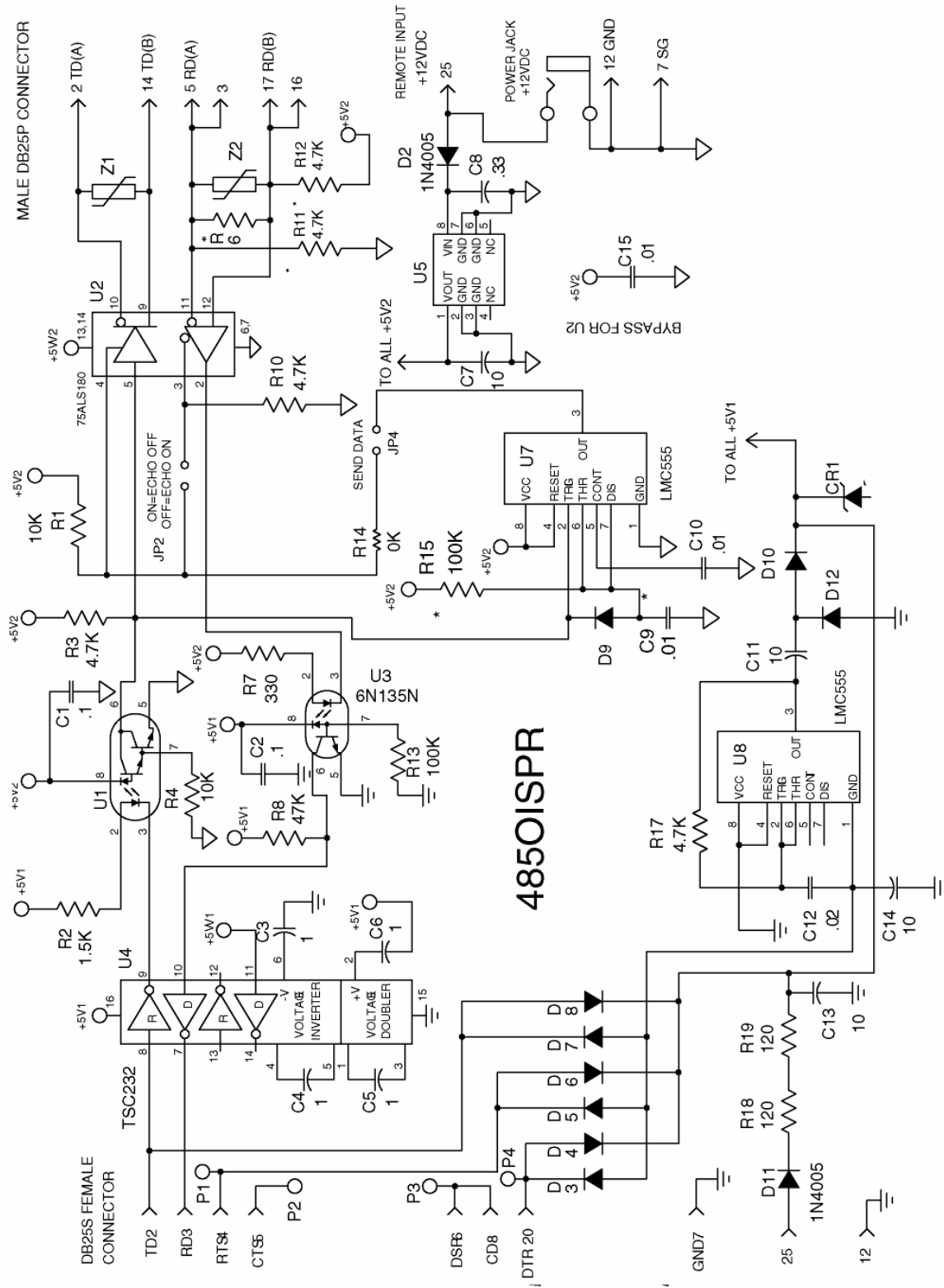

International Headquarters: 707 Dayton Road PO Box 1040 Ottawa, IL 61350 USA
815-433-5100 Fax 433-5104 www.bb-elec.com orders@bb-elec.com support@bb-elec.com

European Headquarters: Westlink Commercial Park Oranmore Co. Galway Ireland
+353 91 792444 Fax +353 91 792445 www.bb-europe.com orders@bb-europe.com support@bb-europe.com