

Optically Isolated RS-232 to RS-485 Converter CE

Model 485OIC



The Model 485OIC converts unbalanced, full or half-duplex RS-232 signals to optically isolated, balanced, full or half-duplex RS-422 or RS-485 signals at baud rates up to 38400 bps. RS-485 is an enhanced version of the RS-422 Standard. It allows multiple drivers and receivers on a two-wire system.

The RS-232 port has a male DB25 connector with pins 2(TD), 3(RD), and 7(Signal Ground) supported. Pins 4(RTS) and 5(CTS) are tied together, and pins 6(DSR), 8(CD), and 20(DTR) are also tied together. These handshake lines provide power for the RS-232 side of the isolator. If you have a port that cannot supply these pins, or if they cannot provide enough power, a power supply can be connected to the DB-25 connector on pins 25(+) and 12(-) to power the RS-232 side of the converter. Terminal blocks are provided for Transmit Data (A) and (B), Receive Data (A) and (B), RS-485 power and ground as shown in Figure 1. Note that the RS-485 Ground terminal block is the connection for RS-485 Signal Ground as well as the RS-485 power ground. Figure 2 shows how to connect the converter to a two-wire or four-wire system. The resistors R_t (labeled R6 on the converter) are termination resistors that should only be used when very long cable runs are used at high baud rates. If installed, the resistors should equal the characteristic impedance of the line used, normally about 120 ohms. Refer to B&B's RS-422/485 Application Note for more information on termination and biasing.

The 485OIC enables the RS-485 driver by automatic sensing of the data on Transmit Data (pin 2) of the RS-232 side. The 485OIC has two jumpers located adjacent to the terminal blocks. JP2 enables either RS-422 or RS-485 mode. Placing JP2 in the shorting position enables RS-485 mode, removing the jumper switches to RS-422 mode. JP1 is used in two wire connections, preventing data being sent from the RS-232 port from being echoed back to the RS-232 port. Placing JP1 in the shorting position will prevent the data from echoing. Removing the jumper will hold the receiver enabled. Refer to Table 2 for typical jumper settings.

There are two internal components, resistor R12 and capacitor C7, which control timing of the automatic send data circuit. These components are factory selected to allow the converter to run at 9600 baud or higher, disabling the RS-485 driver 1 ms after the last character has been sent. To change to a baud rate lower than 9600 baud, or to configure the 485OIC for a specific baud rate, these component values need to be changed. Due to the surface mount construction of the converter, space for through-hole components has been provided on the opposite side of the PCB as R12 and C7. These through-hole components are electrically in parallel with R12 and C7. To change to a baud rate other than 9600, remove R12 and C7, select the proper values for the baud rate from Table 1 and install them in the spaces labeled R18 and C14.

Up to 32 receivers can be driven by any one RS-485 driver, allowing you to put together large systems with many drop points. No wire type or maximum run length is listed in the RS-485 Standard. However, The RS-422 Standard (which is very similar) recommends number 24AWG twisted pair telephone cable with a shunt capacitance of 16 picofarads per foot, and no more than 4000 feet long. Proper operation of any RS-485 system requires the presence of a return path. The RS-485 Standard recommends that a third wire be used for this.

Figure 1: Timing Component Locations

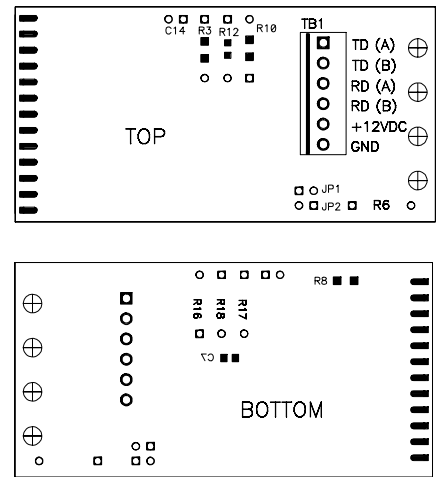

Table 1. Timing Component Values

Baud Rate	Time (ms)	R18 (Ω)	C14 (μ F)
300	33.0	330K	0.1
600	16.0	160K	0.1
1200	8.2	820K	0.01
2400	4.3	430K	0.01
4800	2.1	200K	0.01
9600	1.04	100K	0.01
19200	0.6	56K	0.01
38400	0.3	27K	0.01

Table 2. Jumper Settings

	JP1	JP2
RS-422	Off	Off
RS-485 2-wire	On	On
RS-485 4-wire	Off	On

DECLARATION OF CONFORMITY

Manufacturer's Name: B&B Electronics Manufacturing Company
 Manufacturer's Address: P.O. Box 1040
 707 Dayton Road
 Ottawa, IL 61350 USA

Model Numbers: 485OIC
 Description: RS-232/485 Optically Isolated Converter
 Type: Light industrial ITE equipment
 Application of Council Directive: 89/336/EEC

Standards: EN 50082-1 (IEC 801-2, IEC 801-3, IEC 801-4)
 EN 50081-1 (EN 55022, IEC 1000-4-2)
 EN 61000 (-4-2, -4-3, -4-4, -4-5, -4-6, -4-8, -4-11)
 ENV 50204
 EN 55024



CE

Michael J. Fahrion, Director of Engineering

© B&B Electronics 1993 -- Revised November 2000

This product designed and manufactured in USA of domestic and imported parts by

B & B Electronics Mfg. Co.

707 Dayton Road - P.O. Box 1040 - Ottawa, IL 61350 USA
 Phone: (815) 433-5100 - Fax: (815) 433-5105

Home Page: www.bb-elec.com

Sales e-mail: orders@bb-elec.com - Fax: (815) 433-5109

Technical Support e-mail: support@bb-elec.com - Fax: (815) 433-5104

B & B Electronics Ltd

Westlink Commercial Park - Oranmore, Co. Galway - Ireland
 Phone: +353 91 792444 - Fax: +353 91 792445

Home Page: www.bb-europe.com

Sales e-mail: orders@bb-europe.com

Technical Support e-mail: support@bb-europe.com

Figure 2.

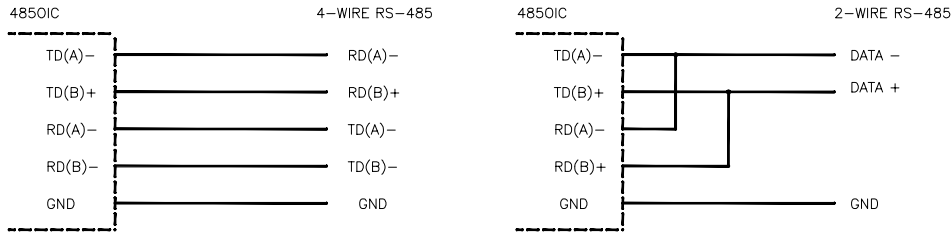

Specifications

Transmission Mode:	Full or half duplex asynchronous
Data Rate:	Up to 38.4K bps
Connectors:	RS-232, DB25 Male; RS-485, Terminal Blocks
RS-485 Enable Control:	Automatic Hardware Control on Presence of Data
RS-485 Enable Timeout:	Factory preset to 1 ms
RS-232 Power Requirements:	Port powered or 10 to 14 VDC @ 40 mA max.
RS-232 External Power Connections:	DB25 pins 25 (+) and 12 (-).
RS-485 Power Requirements:	10 to 14 VDC @ 60 mA max.
RS-485 Power Connections:	Terminal Blocks
Isolation:	1500 VRMS for 1 minute
Dimensions:	3.3"L x 2.2"W x 0.67"H (8.4 x 5.6 x 1.7 cm)

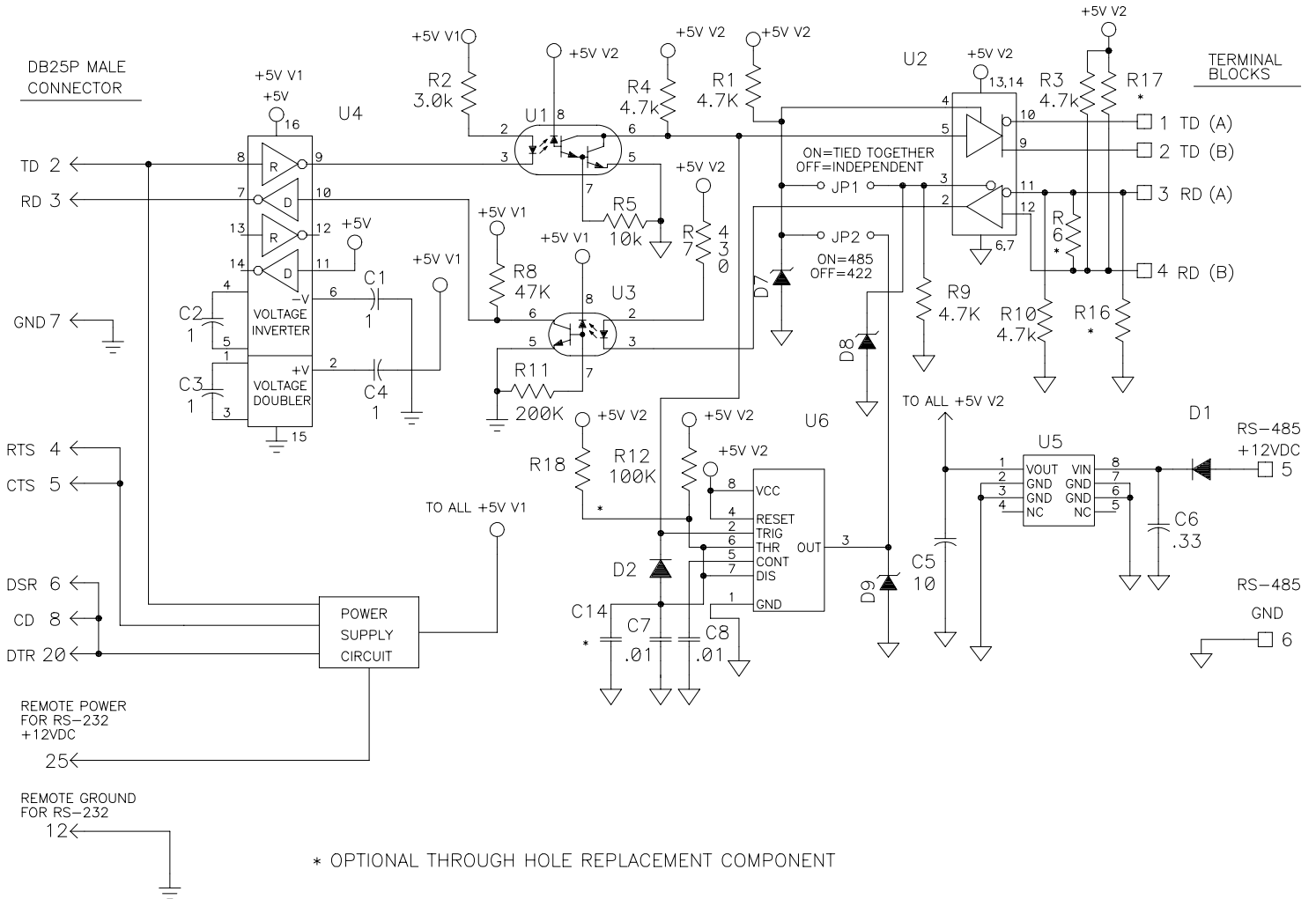

* OPTIONAL THROUGH HOLE REPLACEMENT COMPONENT

© B&B Electronics 1993 -- Revised November 2000

This product designed and manufactured in USA of domestic and imported parts by

B & B Electronics Mfg. Co.

707 Dayton Road - P.O. Box 1040 - Ottawa, IL 61350 USA
 Phone: (815) 433-5100 - Fax: (815) 433-5105

Home Page: www.bb-elec.com
 Sales e-mail: orders@bb-elec.com - Fax: (815) 433-5109
 Technical Support e-mail: support@bb-elec.com - Fax: (815) 433-5104

B & B Electronics Ltd

Westlink Commercial Park - Oranmore, Co. Galway - Ireland
 Phone: +353 91 792444 - Fax: +353 91 792445

Home Page: www.bb-europe.com
 Sales e-mail: orders@bb-europe.com
 Technical Support e-mail: support@bb-europe.com