

Model 485LPCOR Port-Powered RS-485 Converter **CE**

The 485LPCOR is a port-powered two-channel RS-232 to RS-485 converter. It converts the TD and RD RS-232 lines to balanced half-duplex RS-485 signals. The unit is powered from the RS-232 data and handshake lines whether the lines are high or low. An external power supply can be connected to two pins on the RS-485 connector if no handshake lines are available. The 485LPCOR has a DB-25 female connector on the RS-232 side and a DB-25 male connector on the RS-485 side.

RS-232 Side:

Connector: DB-25 Female
Signals: Passes through pins 2 (TD) and 3 (RD).
Pins 4 (RTS) and 5 (CTS) are tied together.
Pins 20 (DTR), 6 (DSR), and 8 (CD) are tied together.

RS-485 Side:

Connector: DB-25 Male
Signals: Half-duplex two-wire operation only.
Automatic control circuit enables driver only when transmitting.
Receiver is disabled when transmitting to prevent echo back to RS-232 device.
Can transmit up to 4000 feet at 115.2k baud.

DECLARATION OF CONFORMITY	
Manufacturer's Name:	B&B Electronics Manufacturing Company
Manufacturer's Address:	P.O. Box 1040 707 Dayton Road Ottawa, IL 61350 USA
Model Number:	485LPCOR
Description:	Port-Powered RS-485 Converter
Type:	Light industrial ITE equipment
Application of Council Directive:	89/336/EEC
Standards:	EN 55022 EN 61000-6-1 EN 61000 (-4-2, -4-3, -4-4, -4-5, -4-6, -4-8, -4-11)
William H. Franklin III, Director of Engineering	
CE	

Power Requirements

No external power required if two RS-232 output handshake lines are available.
External 12VDC can be applied to pins on the RS-485 side between pins 25 (+) and 12 (GND) if handshake lines are not available.

35mA current draw maximum under normal operation when externally powered.

NOTE: When using an external supply, the supply should be connected only to specifically labeled power inputs (power jack, terminal block, etc.). Connecting an external power supply to the handshake lines may damage the unit. Contact technical support for more information on connecting an external power supply to the handshake lines.

Dimensions: 2.20 x 2.16 x 0.64 in (5.59 x 5.49 x 1.63 cm)

Connections and Operation

To DB-25 RS-232 DTE device:

To DB-25 RS-232 DCE device:

To RS-485 device or network:

485LPCOR DB25S	RS-232 DTE DEVICE	485LPCOR DB25S	RS-232 DCE DEVICE	485LPCOR DB25P	OUT TO RS-485 NETWORK
2	2	2	3	2	DATA A (-)
3	3	3	2	14	DATA B (+)
4	4	5	5	7	SIG. GND
20	20	6 or 8	6 or 8		
7	7	7	7		

Can use 25-pin straight through cable.

Can use 25-pin cable that crosses pins 2 & 3.

International Headquarters:

B&B Electronics Mfg. Co. 707 Dayton Road P.O. Box 1040 Ottawa, IL 61350 USA
815-433-5100 Fax 433-5104 www.bb-elec.com orders@bb-elec.com support@bb-elec.com

B&B Electronics Ltd Westlink Commercial Park Oranmore Co. Galway Ireland
+353 91 792444 Fax +353 91 792445 www.bb-europe.com orders@bb-elec.com support@bb-europe.com

Pin one is also connected straight through on the 485LPCOR from the RS-232 side to the RS-485 side so that the shield can be passed through to earth ground if desired. It is recommended that shielded cable be used and that the shield be connected to earth ground at one point in the system. See B&B Electronics' RS-422/RS-485 Application Note for further information on shielding.

Although the 485LPCOR uses the handshake lines to power the converter, no handshaking is required to control the RS-485 driver. The RS-485 driver is automatically enabled during each spacing state on the RS-232 side. During the marking or idle state, the RS-485 driver is disabled and the data lines are held in the marking state by the 4.7K ohm pull-up and pull-down resistors. The value of these resistors may need to be changed to a different value when termination is used in order to maintain the proper DC bias during the idle state. See B&B Electronics' RS-422/RS-485 Application Note for more information on termination and DC biasing of an RS-485 network.

The 485LPCOR has an internal connection to prevent data transmitted from the RS-232 port from being echoed back to the RS-232 port. The connection can be cut to have the receiver always enabled. (See Figure 1.) After the connection is cut, a jumper wire from pin 18 to pin 21 can be installed to disable the receiver during transmission.

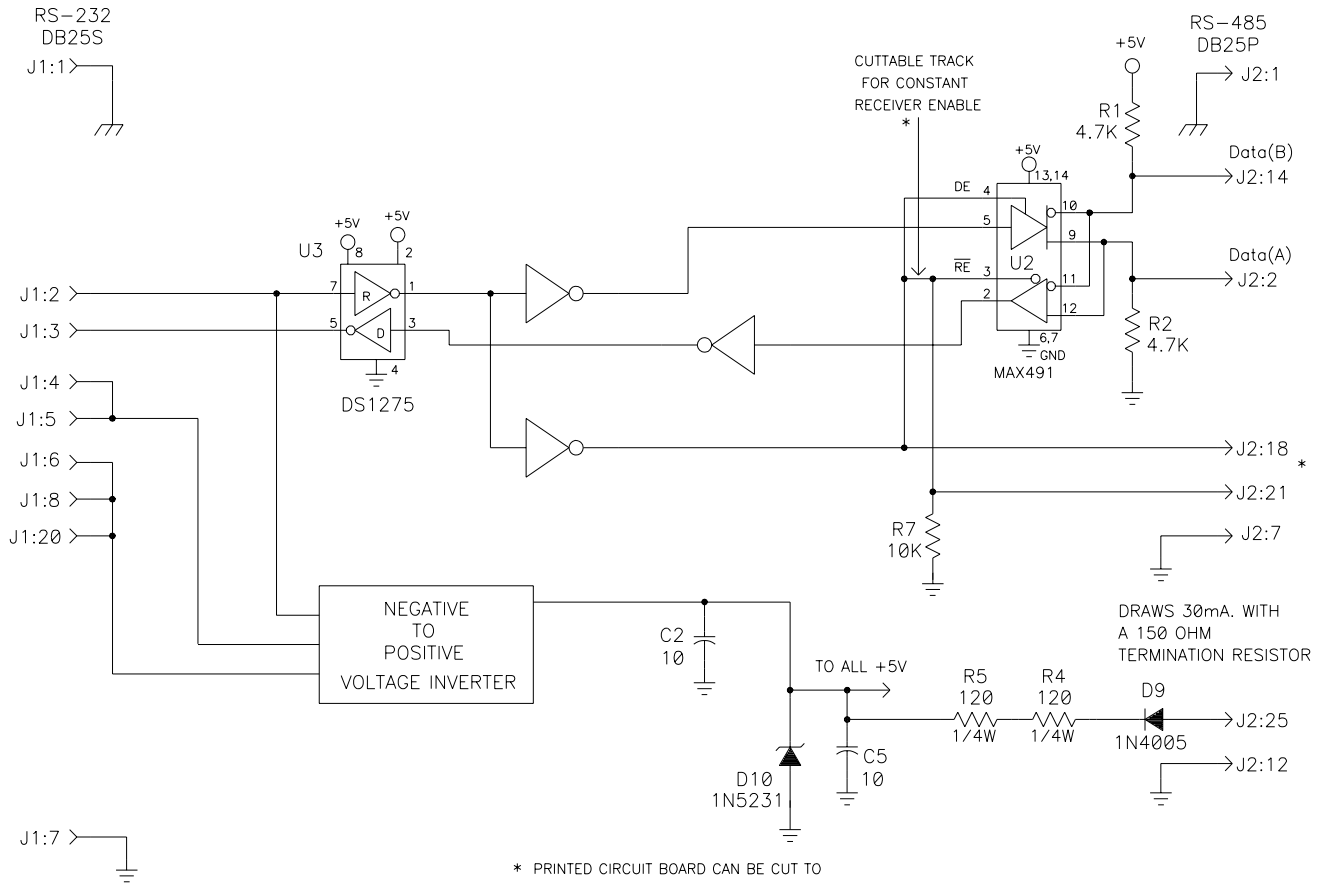
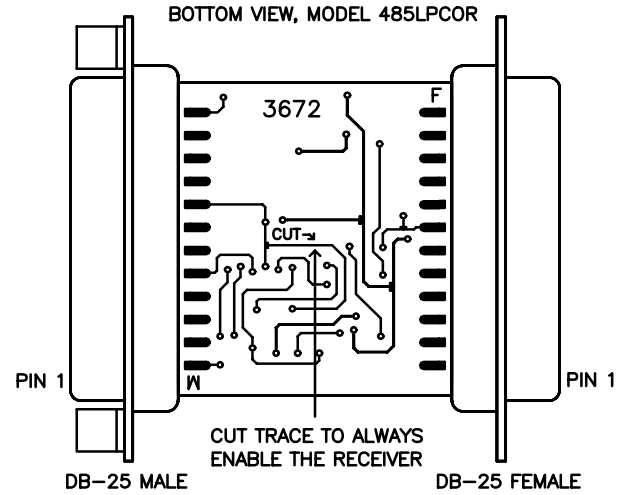

MODEL 485LPCOR

International Headquarters:

B&B Electronics Mfg. Co. 707 Dayton Road P.O. Box 1040 Ottawa, IL 61350 USA
815-433-5100 Fax 433-5104 www.bb-elec.com orders@bb-elec.com support@bb-elec.com

B&B Electronics Ltd Westlink Commercial Park Oranmore Co. Galway Ireland
+353 91 792444 Fax +353 91 792445 www.bb-europe.com orders@bb-elec.com support@bb-europe.com