

RS-232 to RS-485 Converter CE

Model 485COSR

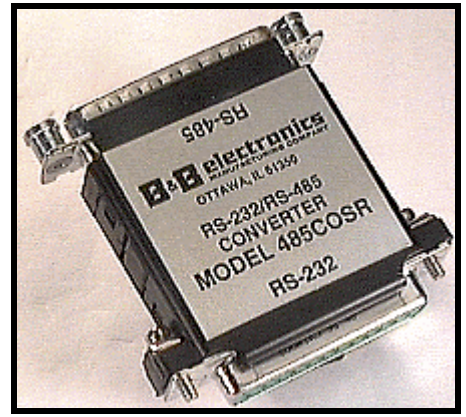

The RS-232 to RS-485 Converter converts unbalanced, full-duplex RS-232 signals to balanced full-duplex (4-wire), or half-duplex (2-wire) RS-485 signals. RS-485 is an enhanced version of the RS-422 balanced line standard.

The RS-232 port has a female DB25S type of connector with pins 2 (TD input) and 3(RD output) supported. Protective Ground (pin 1) and Signal Ground (pin 7) are also passed through. Pins 4(RTS) and 5(CTS) are tied together. Also pins 6(DSR), 8(CD), and 20(DTR) are tied together, but not passed through the converter. The RS-485 port has a male DB25P type of connector with the Send Data outputs on pins 2 and 14, and Receive Data inputs on pins 3 and 16 or 5 and 17.

Figure 2 shows how to interconnect two RS-485 Converters using two signal wires. The resistors R_t are optional, depending on the line length, baud rate, etc. The resistors should be about the impedance of the line used, but in no case should they be less than 120 ohms each. No special software requirements are needed, since the 485 driver is enabled by the first transition on the RS-232 side of the transmit data line (Pin 2). Any transition on the TD line keeps the RS-485 driver enabled by preventing the monostable multivibrator from timing out. The transmitter is disabled approximately 1 ms after the last transmitted character. This 1 ms timeout allows continuous transmission of data at 9600 baud or higher. If other baud rates are required, see Table 1.

Table 1			
COMPONENT REPLACEMENTS FOR CHANGING BAUD RATE TIMEOUTS			
Baud Rate	Time (ms)	Resistor (R6) (ohm)	Capacitor (C7) (mfd)
300	33.3	330K	0.1
600	16.6	160K	0.1
1200	8.33	820K	0.01
2400	4.16	430K	0.01
4800	2.08	200K	0.01
9600	1.04	100K	0.01
19200	.520	56K	0.01
38400	.260	27K	0.01
57600	.176	16K	0.01
115200	.0868	8.2K	0.01

The 485COSR has an internal connection to prevent data transmitted from the RS-232 port from being echoed back to the RS-232 port. The connection can be removed to have the receiver always enabled. (Refer to schematic) After the connection is removed, a jumper wire from pin 18 to pin 21 can be installed to disable the receiver during transmission. Up to 32 receivers can be driven by any one driver. This allows you to put together large systems with many drop points. The termination resistors should be located approximately at opposite ends of the system.

Proper operation of any RS-485 system requires the presence of a signal return path. The RS-485 Standard recommends that a third wire be used for this. For safety, a 100 ohm half-watt resistor should be connected between pin 7 and the "reference" wire at every drop point. While it may be possible to interconnect signal grounds (pin 7's) directly, this is not recommended due to the danger of circulating currents possibly being present.

No wire type or maximum run length is listed in the RS-485 Standard. However, the RS-422 Standard, which is very similar, recommends number 24 AWG twisted-pair telephone cable with a shunt capacitance of 16 picofarad per foot and no more than 4000 ft. of distance.

The polarity of the two RS-485 lines must be correct. With no data being sent, the RS-232 line should be negative and the RS-485 "A" terminal should be negative with respect to the "B" terminal. If your equipment uses a "+" and "-" naming scheme, in most cases the "A" line will be connected to the "-" and the "B" line will be connected to the "+".

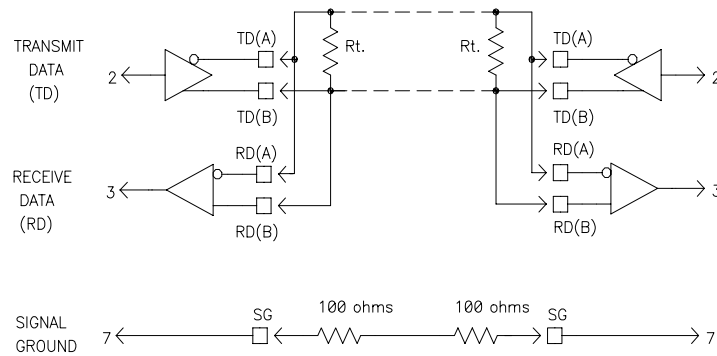

FIGURE 2. INTERCONNECTION DRAWING

DECLARATION OF CONFORMITY

Manufacturer's Name:	B&B Electronics Manufacturing Company
Manufacturer's Address:	P.O. Box 1040 707 Dayton Road Ottawa, IL 61350 USA
Model Number:	485COSR
Description:	2-Channel RS-485 Converter w/SD Control
Description:	RS-485 Optically Isolated Din Mount Converter
Type:	Light industrial ITE equipment
Application of Council Directive:	89/336/EEC
Standards:	EN 50082-1 (IEC 801-2, IEC 801-3, IEC 801-4) EN 50081-1 (EN 55022, IEC 1000-4-2) EN 61000 (-4-2, -4-3, -4-4, -4-5, -4-6, -4-8, -4-11) ENV 50204 EN 55024

Michael J. Fahrion, Director of Engineering

© 1993 B&B Electronics - Revised November 2000

This product designed and manufactured in USA of domestic and imported parts by

B & B Electronics Mfg. Co.

707 Dayton Road - P.O. Box 1040 - Ottawa, IL 61350 USA
Phone: (815) 433-5100 - Fax: (815) 433-5105

Home Page: www.bb-elec.com

Sales e-mail: orders@bb-elec.com - Fax: (815) 433-5109

Technical Support e-mail: support@bb-elec.com - Fax: (815) 433-5104

B & B Electronics Ltd

Westlink Commercial Park - Oranmore, Co. Galway - Ireland
Phone: +353 91 792444 - Fax: +353 91 792445

Home Page: www.bb-europe.com

Sales e-mail: orders@bb-europe.com

Technical Support e-mail: support@bb-europe.com

MODEL 485COSR

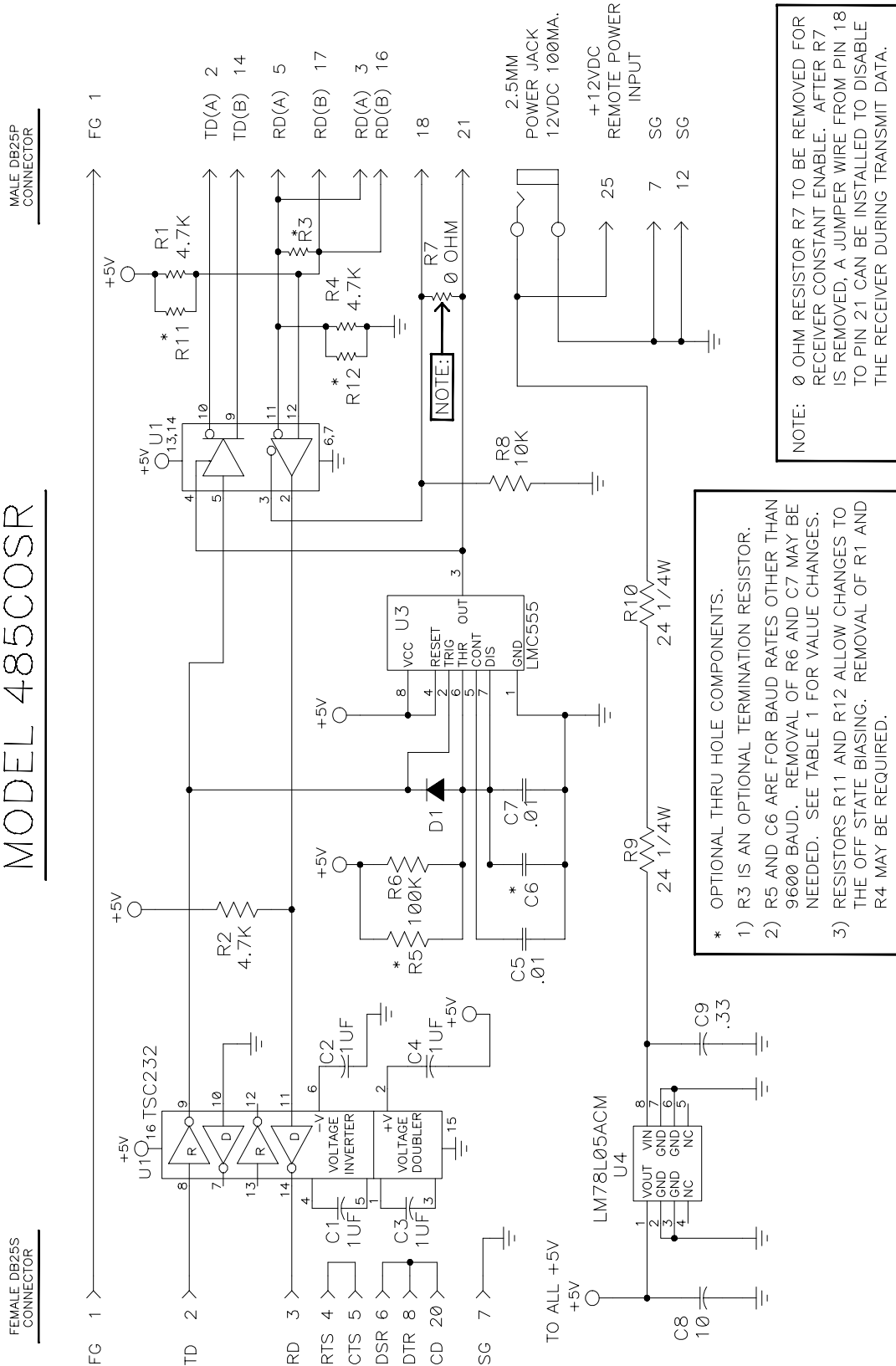

© 1993 B&B Electronics - Revised November 2000

This product designed and manufactured in USA of domestic and imported parts by

B & B Electronics Mfg. Co.

707 Dayton Road - P.O. Box 1040 - Ottawa, IL 61350 USA

Phone: (815) 433-5100 - Fax: (815) 433-5105

Home Page: www.bb-elec.com

Sales e-mail: orders@bb-elec.com - Fax: (815) 433-5109

Technical Support e-mail: support@bb-elec.com - Fax: (815) 433-5104

B & B Electronics Ltd

Westlink Commercial Park - Oranmore, Co. Galway - Ireland

Phone: +353 91 792444 - Fax: +353 91 792445

Home Page: www.bb-europe.com

Sales e-mail: orders@bb-europe.com

Technical Support e-mail: support@bb-europe.com