

Product End of Life Notification

Date: September 28th, 2011

Product Being Discontinued

| Model Number | Description |
|--------------|--------------------------------|
| 485OT9L | 9PIN 232/485 ISOL CON W/TB&LED |

Replacement Product

| Model Number | Description |
|---------------|--|
| 4WSD9OTB | 9PIN 232/485 ISOL CON W/TB&LED |
| SCP311T-DFTB3 | SERIAL CONVERTER, PANEL MOUNT, ISOLATED, WIDE TEMP |

Orders will be accepted and shipped until the following dates

| | |
|-----------------|----------------------------------|
| Last Time Buy: | November 21 st , 2011 |
| Last Time Ship: | December 30 th , 2011 |

Please contact us immediately if you have any special needs for this product or have any other concerns.

Thank You,

Brian Foster, Product Manager
bfoster@bb-elec.com

Models: 4WSD9OTB/4WSD25OTB

Isolated Universal Converters

RS-232, 4-wire RS-422, 2-wire or 4-wire RS-485



Features

- ✓ **High Speed Communications.** Supports data rates up to 115.2 kbps.
- ✓ **Extended communications.** Supports distances up to 4000 ft (1200 m).
- ✓ **Removable terminal blocks for easy RS-422/RS-485 connections.**
- ✓ **Switchable modes.** Supports 2-wire RS-485, 4-wire RS-485, and full duplex RS-422.
- ✓ **Automatic RS-485 driver control.** External software modifications are not required.
- ✓ **2000 VAC isolation.** Reliable in harsh electrical conditions.

Functional Description

Isolates and converts RS-232 signals into RS-422 / RS-485 signals and vice versa. Unlike other converters, external software is not required to control data flow. The RS-232 input is wired for DCE and interfaced through a female DB25 or DB9 connector. RS-422 or RS-485 signals are connected to a removable terminal block. External power is applied to separate removable terminal block. A 10 – 48 VDC power supply (not included) is required.

Ordering Information

| Model Number | Description |
|--------------|---|
| 4WSD9OTB | Converter with female DB9 RS-232 Connector |
| 4WSD25OTB | Converter with female DB25 RS-232 Connector |
| 7175 | Power 2-position Terminal Block – one included |
| 7372 | Data 5-position Terminal Block – one included |
| 9PAMF6 | 6ft. Serial Cable DB9M to DB9F |
| 485PS2 | 120 VAC to 12 VDC Power Supply |
| PS2EU-1000 | 220/240 VAC to 12 VDC Power Supply; 2-Prong Euro Plug |
| PS2UK-1000 | 220/240 VAC to 12 VDC Power Supply; 3-Prong UK Plug |



International Headquarters: 707 Dayton Road PO Box 1040 Ottawa, IL 61350 USA
815-433-5100 Fax 433-5104 www.bb-elec.com orders@bb-elec.com support@bb-elec.com

European Headquarters: Westlink Commercial Park Oranmore Co. Galway Ireland
+353 91 792444 Fax +353 91 792445 www.bb-europe.com orders@bb-europe.com support@bb-europe.com

Operation

- Configure operating mode using guidance in Table 1.
- Common Applications are discussed in Figures 1 through 3.
- RS-232 connection requires RD, TD, and Signal Ground. The remaining signals are looped back within the converter as shown in Table 2.
- In half duplex operation, the receiver is enabled when not transmitting (Echo Off).
- In RS-422 mode, the driver is always enabled.
- In RS-485 mode, the RS-485 driver is automatically enabled during each space state by the presence of an RS-232 signal. When the RS-232 data is in a mark or idle state, the RS-485 driver is disabled and the RS-485 data lines are held in a mark state by the bias provided by a 4.7K Ω resistor. The value of this resistor may need to be changed depending on the termination used.
- Refer to B&B Electronics' RS-422/RS-485 Application Note for detailed information concerning RS-422 and RS-485 networks. This document is available for download at http://www.bb-elec.com/tech_articles.
- The loopback test mode switch is used with hyper terminal to verify the operation of the converter. Additional troubleshooting guidance is available at http://www.bb-elec.com/technical_library.asp.

Table 1 – Operating Mode Switch Settings

| Switches | Switch 1 (Tx) | Switch 2 (Rx) | Switch 3 (bridge) | Switch 4 (bridge) |
|----------------------------------|---------------|---------------|-------------------|-------------------|
| Operating Mode | | | | |
| RS-485 2-Wire Mode (half duplex) | RS-485 | Echo Off | 2-Wire | 2-Wire |
| RS-485 4-Wire Mode (full duplex) | RS-485 | Echo On | 4-Wire | 4-Wire |
| RS-422 4-Wire Mode (full duplex) | RS-422 | Echo On | 4-Wire | 4-Wire |
| Loopback Test Mode* | As Desired | Echo On | 2-Wire | 2-Wire |

- Used with HyperTerminal or another terminal program to confirm operation of data through converter.

Table 2 – RS-232 Pin-out

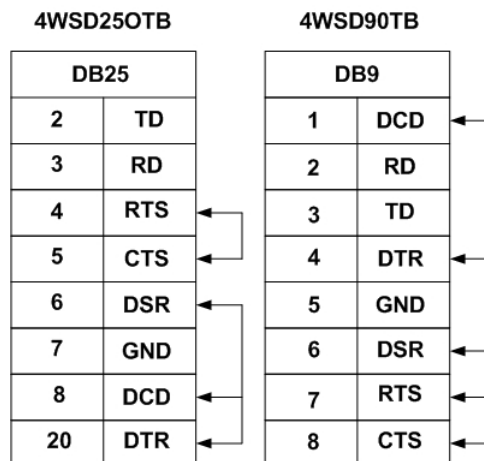

Loop back jumpers
are pre-wired within
the converter



International Headquarters: 707 Dayton Road PO Box 1040 Ottawa, IL 61350 USA
815-433-5100 Fax 433-5104 www.bb-elec.com orders@bb-elec.com support@bb-elec.com

European Headquarters: Westlink Commercial Park Oranmore Co. Galway Ireland
+353 91 792444 Fax +353 91 792445 www.bb-europe.com orders@bb-europe.com support@bb-europe.com

Figure 1: 2-Wire RS-485

- Used to connect several RS-485 devices with minimal wire.
- Devices communicate one at a time.
- Units are normally in receive mode.
- When data is requested, the addressed device waits one delay time before responding.
- After transmitting, the device reverts to receive.
- Switch settings are: Switch 1: RS-485, Switch 2: Echo Off, Switches 3 and 4 to 2-Wire.

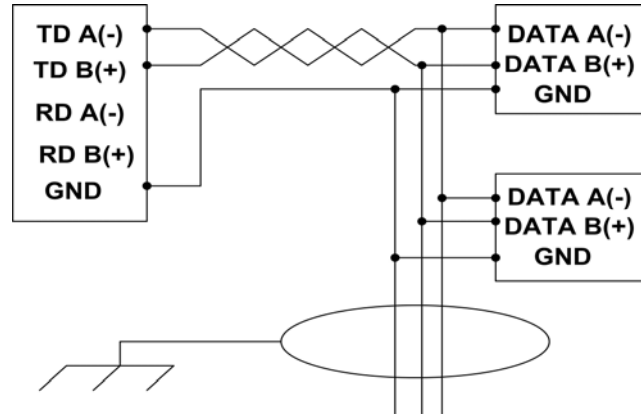
**Figure 2: 4-Wire RS-485**

- Used for 4-Wire Master/Slave circuits.
- Each device is polled, allowing faster response time.
- Addressed devices can receive while responding to a request.
- When used as a Master in a single master system, Switch 1 may be set RS-422 since it is the only transmitter.
- When used as a slave, the RS-232 device must provide addressability. Select RS-485 mode in this situation.
- Biasing is provided by the end-of-line slave.
- Switch settings for this mode are : Switch 1: RS-485, Switch 2: Echo On, Switches 3 and 4: 4-wire.

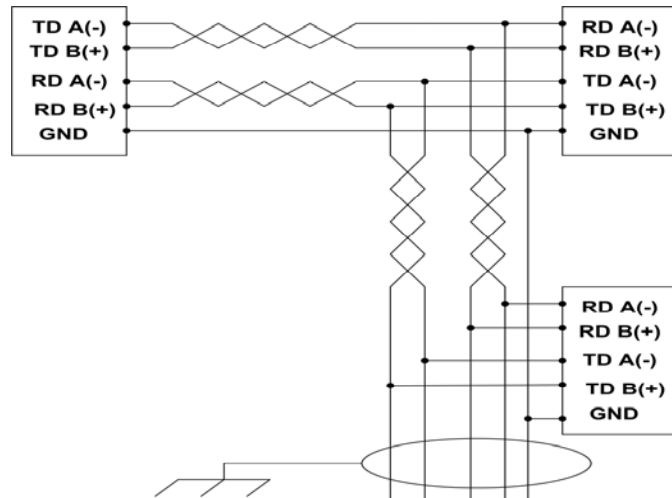
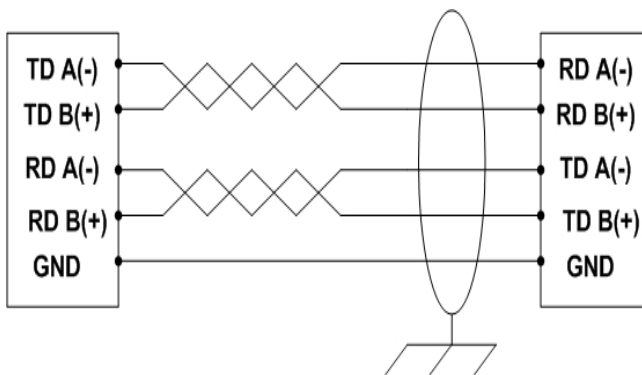

Figure 3: 4-wire RS-422

- Used as the master in a master/slave circuit with receive only slaves.
- Full-duplex communications.
- Requires a twisted pair for transmit, a twisted pair for receive, and a ground reference wire.
- Switch settings are: Switch 1: RS-422, Switch 2: Echo On, Switches 3 and 4: 4-wire.



Specifications

DECLARATION OF CONFORMITY

Manufacturer's Name: B&B Electronics Manufacturing Company
 Manufacturer's Address: P.O. Box 1040
 707 Dayton Road
 Ottawa, IL 61350 USA
 Model Number: 4WSDxxOTB
 Description: RS-422/485 Converter
 Type: Light industrial ITE equipment
 Application of Council Directive: 89/336/EEC
 Standards: EN 55022
 EN 61000-6-1
 EN 61000 (-4-2, -4-3, -4-4, -4-5, -4-6, -4-8, -4-11)

MJ Fahrion

Michael J. Fahrion, Director of Engineering

CE

| | |
|--------------------------|--|
| Input Power Requirement | 10 – 48 VDC |
| Isolation | 2000 VAC |
| Current Draw | 28 mA at 12 VDC (typical) |
| RS-232 Connection | DB9/DB25 |
| RS-422/RS-485 Connection | Removable Terminal Block |
| Data Rate | Up to 115.2 kbps |
| Operating Temperature | 32 – 158°F (0 - 70°C) |
| LED Indicators | TD and RD |
| Dimensions (4WSD9OTB) | 3.9 x 1.7 x 0.9 in 9.8 x 4.3 x 2.3 cm |
| Dimensions (4WSD25OTB) | 3.9 x 2.2 x 0.9 in 9.8 x 5.5 x 2.3 cm |
| Approvals | CE |



International Headquarters: 707 Dayton Road PO Box 1040 Ottawa, IL 61350 USA
 815-433-5100 Fax 433-5104 www.bb-elec.com orders@bb-elec.com support@bb-elec.com

European Headquarters: Westlink Commercial Park Oranmore Co. Galway Ireland
 +353 91 792444 Fax +353 91 792445 www.bb-europe.com orders@bb-europe.com support@bb-europe.com

SCP211 & SCP311

RS-232 to RS-422/485 Converters

- ✓ **Isolated and Non-Isolated Models**
- ✓ **ESD Protection - 8 kV Contact, 15 kV Air**
- ✓ **Rugged Metal Case**
- ✓ **Wide Operating Temperature Models**
- ✓ **Panel Mount with Available DIN Rail Adapters**
- ✓ **Built in Switchable Bias & Termination**



SCP Series RS-232 to RS-422/485 Converter – Shown with optional DIN Rail Adapter

Our SCP series RS-232 to RS-422/485 serial converters are compact and tough. Each model is designed and tested to meet heavy industrial EMC standards. The RS-232 signal is connected through a female DB9 connector. The RS-422/485 (2-Wire and 4-Wire) signal is connected through a removable terminal block, making wiring easy. Power is connected through a two position removable terminal block. Our bit-wise enabled circuitry automatically detects the character time-out eliminating the need to set DIP Switches for the baud rate.

The basic model, SCP211-DFTB3, is non-isolated and made for less demanding temperature extremes. If you need a wider operating temperature but do not require isolation, model SCP211T-DFTB3 is available. These models should be used when isolation is not required, such as applications in which the data line does not exit the control cabinet.

Model SCP311T-DFTB3 offers 2 kV Isolation and will stand up to -40 to 80° C temperature variations. This is our most rugged model in this series. The SCP311 is an excellent investment for protecting your expensive control equipment.

Specifications

Serial Technology

| | |
|------------------|--|
| RS-232 | TD, RD, GND |
| RS-422/485 4W | TDA(-), RDA(-), TDB(+), RDB(+), GND |
| RS-485 2W | DATA A(-), DATA B(+), GND |
| Data Rate | 460.8 Kbps |
| Isolation | 2 kV (SCP311T-DFTB3) |
| Surge Protection | +/- 0.5 kV DC Ports, +/- 1 kV Signal Ports |
| Industrial Bus | Modbus ASCII/RTU |
| Bias | 1 K Ω Switchable |
| Termination | 120 Ω Switchable |
| Connectors | RS-232 – DB9F (DCE) RS-422/485 – Removable Terminal Block |

Power

| | |
|-------------------|------------------|
| Source | External |
| Power Connector | Terminal Block |
| Input Voltage | 10 to 30 VDC |
| Power Consumption | 1.0 Watt Maximum |

Indicators

| | |
|---------|---|
| TD / RD | Green LED (Also used to indicate power) |
|---------|---|

Mechanical

| | |
|--------------------|-----------------------------------|
| Dimensions | 99x22.9x73.7 mm (3.9x0.9 x2.9 in) |
| Enclosure | IP 30, Metal |
| Weight | 0.33 lbs, 0.15 kg |
| MTBF SCP211 Series | 313926 Hours |
| MTBF SCP311T-DFTB3 | 217576 Hours |
| MTBF Calc. Method | MIL 217F Parts Count Reliability |

Environmental

| | |
|-----------------------|-------------------------|
| Operating Temperature | |
| SCP211-DFTB3 | 0 to 70°C |
| SCP211T-DFTB3 | -40 to 80°C |
| SCP311T-DFTB3 | -40 to 80°C |
| Storage Temperature | -40 to 85°C |
| Operating Humidity | 0 to 95% Non-condensing |

Ordering Information

| | |
|---------------|--|
| SCP211-DFTB3 | RS-232 to 422/485 Converter |
| SCP211T-DFTB3 | Wide-Temp, RS-232 to RS-422/485 Converter |
| SCP311T-DFTB3 | Wide-Temp, Isolated, RS-232 to 422/485 Converter |
| DRAD35 | DIN Rail Adapter |
| PS5R-A24 | 24 VDC, 7.5 W Power Supply, DIN / Panel Mount |
| TBKT1 | Replacement TB, 2 Position |
| TBKT2 | Replacement TB, 5 Position |

| Approvals / Certifications | | | |
|----------------------------|--------------------------------------|--------------------|-----------------------------|
| Emissions | FCC Class B, CISPR Class B (EN55022) | | |
| CE | EN61000-6-2:2005 | (Heavy Industrial) | |
| | EN61000-4-2:2008 | (ESD) | 8kV contact, 15kV air |
| | EN61000-4-3:2006 | (RI) | 10 V/m |
| | EN61000-4-4:2004 | (EFT Burst) | 1kV signal, 2kV power |
| | EN61000-4-5:2005 | (Surge) | 1kV signal, 500V DC, 1kV AC |
| | EN61000-4-6:2005 | (CI) | 10 Vrms |

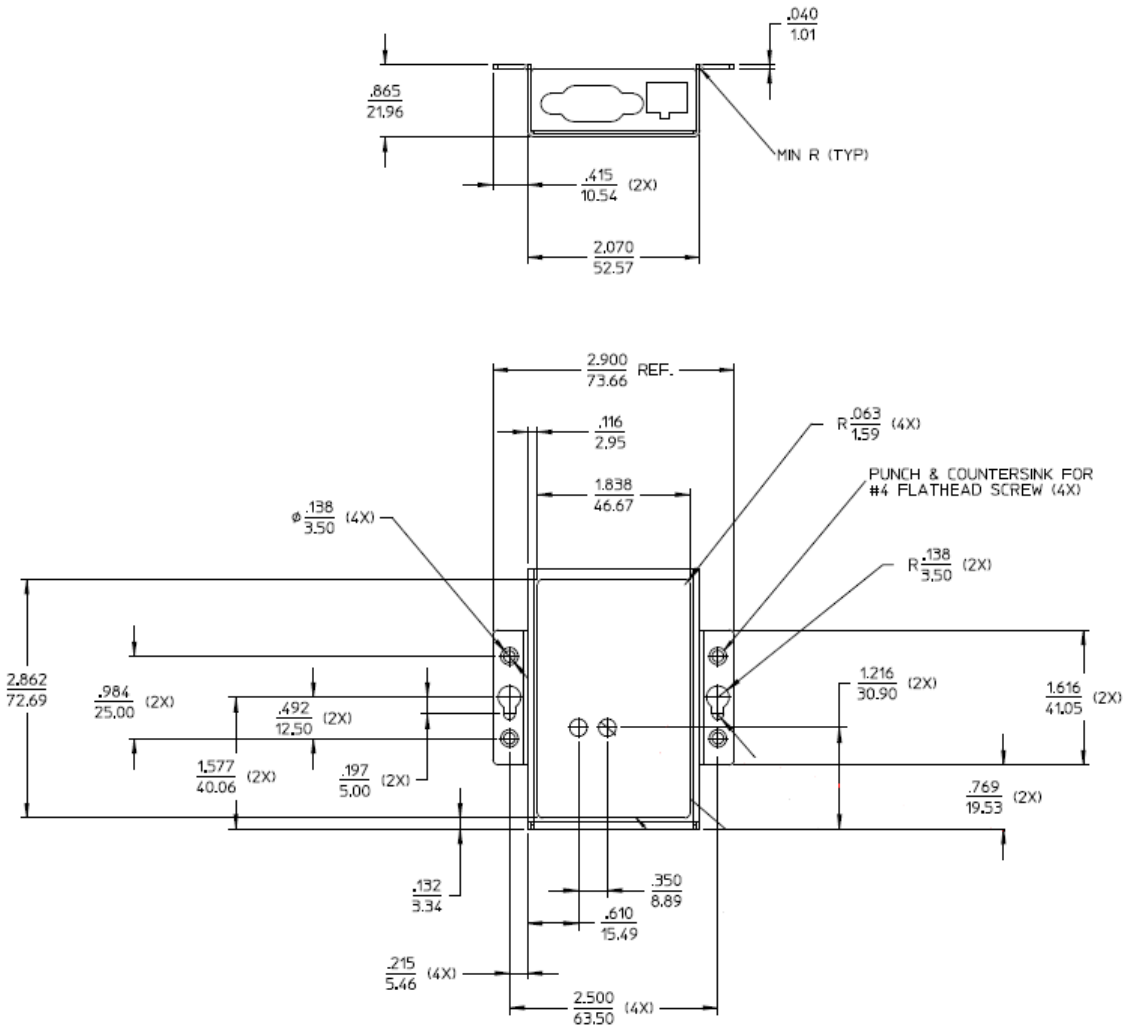



Model 485OT9L 9-Pin RS-232 to RS-485 Optically Isolated Converter **CE**

Introduction

The Model 485OT9L is our most feature-packed RS-232 to RS-422/485 9-pin converter. It converts unbalanced, full or half-duplex RS-232 signals to balanced, full or half-duplex RS-422 or RS-485 signals at baud rates up to 115.2 kbps. In addition, the unit optically isolates and surge suppresses the RS-422/485 lines. The driver uses automatic SD (send data) or RTS (handshake) control, or can be configured as always enabled for use in RS-422 systems.

A dipswitch selects communication features on the 485OT9L. Two LEDs show data traffic in either direction. Only one power supply is necessary, located on the RS-232 side. The isolated power and ground on the RS-422/485 side are generated internally.

Connections are made through a DB9 female connector on the RS-232 side and terminal blocks on the RS-422/485 side. All terminal blocks, dipswitches, and jumpers are located inside the hood and are reachable through the access panel, which slides closed to protect the connections.

Description

The RS-232 port has a DB9 female connector with pins 3 (TD), 2 (RD), and 5 (Signal Ground) supported, pins 7 (RTS) and 8 (CTS) are tied together, and pins 6 (DSR), 1 (CD), and 4 (DTR), are also tied together. The 485OT9L has two LEDs: a Transmit Data LED showing when data goes from the RS-232 side to the RS-485 side, and a Receive Data LED showing data going from the RS-485 side to the RS-232 side. These are very useful for determining if data is getting through the converter. The RS-485 terminal blocks support Transmit Data (A) and (B), Receive Data (A) and (B), and Signal Ground. A single supply voltage of 10 to 30 VDC on the RS-232 side powers the unit. An 8-position dipswitch allows the selection of baud rate, 2-wire or 4-wire mode, echo on or off, and termination in or out.

RS-422/485 Driver Control

The 485OT9L uses either RTS Control or Send Data Control to enable the RS-485 driver. This option is user selectable by setting push-on jumpers located next to the terminal blocks. RTS controls the driver using toggling Request to Send (pin 7) of the RS-232 side. Raising RTS enables the driver and lowering RTS disables it. Automatic Send Data Control recognizes the first bit of data from the RS-232 side, enables the transmitter and disables the receiver. After the last bit of data is sent from the RS-232 side, the 485OT9L waits one character length then disables the transmitter and enables the receiver. The timeout can be selected with dipswitches or by changing the value of R21 (see Table 1). The timeout is preset at the factory for 9600 baud. Removing both sets of jumpers completely will constantly enable the RS-485 driver. This makes the 485OT9L behave like an RS-422 converter. See Table 2 for standard communications settings.

Termination and Echo Options

Termination resistance can be selected with Switch 8 for high baud rates and long cable distances. See B&B Electronics RS-422/485 Application Note for more information (available on the web site or request one by mail). The 4-wire/2-wire switches (6 and 7) are turned off for 4-wire mode and on for 2-wire mode. When they are set on, they connect TD(A) to RD(A) and TD(B) to RD(B) internally. Switch 5 controls Echo on and off. When switch 5 is in the off position the receiver is constantly enabled. Placing the switch in the on position allows the driver or the receiver to be enabled at any time. In 2-wire mode it is recommended that switch 5 be turned on to prevent data being sent out from "echoing" back through the receiver. Up to 32 receivers can be driven by any one RS-485 driver, allowing you to put together large systems with many drop points. Using an RS-422/485 repeater manufactured by B&B Electronics can increase the number of receivers.



International Headquarters: 707 Dayton Road PO Box 1040 Ottawa, IL 61350 USA
815-433-5100 Fax 433-5104 www.bb-elec.com orders@bb-elec.com support@bb-elec.com

European Headquarters: Westlink Commercial Park Oranmore Co. Galway Ireland
+353 91 792444 Fax +353 91 792445 www.bb-europe.com orders@bb-europe.com support@bb-europe.com

Table 1. Baud Rate Selection

| Baud | Switch 1 | Switch 2 | Switch 3 | Switch 4 | R21 | Time out (ms) |
|--------|----------|----------|----------|----------|----------|---------------|
| 1200 | OFF | OFF | OFF | OFF | 820kΩ | 9.0 |
| 2400 | OFF | OFF | OFF | OFF | 410kΩ | 4.5 |
| 4800 | ON | OFF | OFF | OFF | Not Used | 2.2 |
| 9600 | OFF | ON | OFF | OFF | Not Used | 1.1 |
| 19200 | OFF | OFF | ON | OFF | Not Used | 0.6 |
| 38400 | OFF | OFF | OFF | ON | Not Used | 0.3 |
| 57600 | OFF | OFF | ON | ON | Not Used | 0.2 |
| 115200 | OFF | OFF | OFF | OFF | 8.2kΩ | 0.1 |

Table 2. Standard Communications Settings

| Communication Mode | JP1 | Switch 5 Echo | Switch 6 4W/2W | Switch 7 4W/2W |
|-------------------------------------|-----------|------------------|-------------------|-------------------|
| RS-422 Mode (full-duplex) | Neither | OFF | OFF | OFF |
| RS-485 4-Wire Mode (full-duplex) | RTS or SD | OFF | OFF | OFF |
| RS-485 2-Wire Mode (half-duplex) | RTS or SD | ON | ON | ON |

Typical RS-422/485 2 Wire Setup

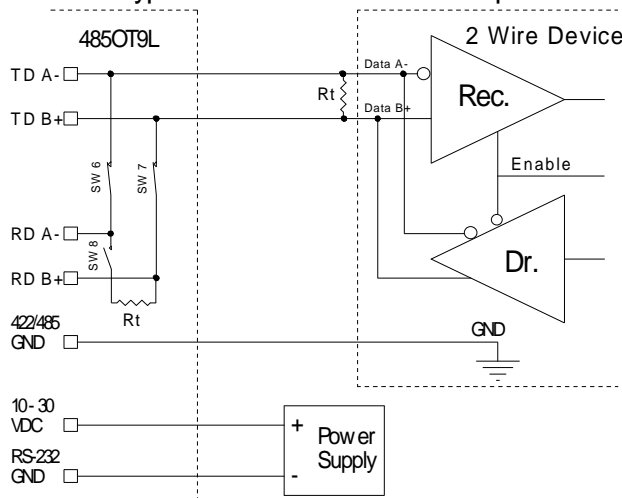

Typical RS-422/485 4 Wire Setup

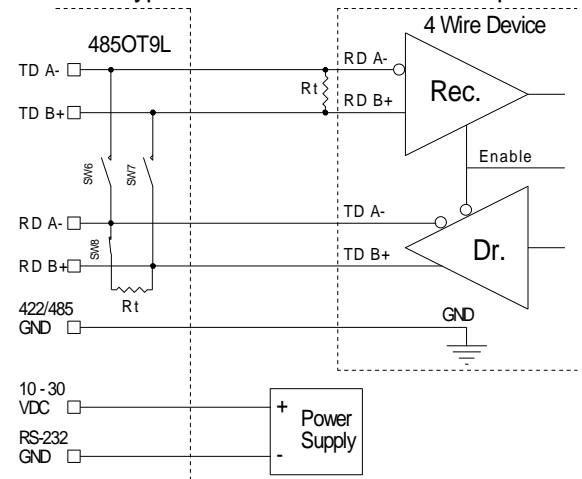

Specifications

- Dimensions: 2.7 x 5.1 x 0.9 in (7.0 x 13.0 x 24.0 cm)
- Temperature Range: 0°C to 70°C
- Supply Voltage: +10 to 30 VDC @ 95 mA maximum
- Data Rates: up to 115.2 kbps
- Connectors: DB9 female for RS-232
Terminal blocks for RS-422/485 and power
- Isolation: 2000 VAC optical isolation of data signals and ground
- Surge Suppression: 7.5V, bi-directional avalanche breakdown device.
500W peak power dissipation
Clamping time <1 picosecond (theoretical)

DECLARATION OF CONFORMITY

Manufacturer's Name: B&B Electronics Manufacturing Company
 Manufacturer's Address: P.O. Box 1040
 707 Dayton Road
 Ottawa, IL 61350 USA
 Model Numbers: 485OT9L
 Description: RS-232/485 Optically Isolated Converter
 Type: Light industrial ITE equipment
 Application of Council Directive: 89/336/EEC
 Standards: EN 55022
 EN 61000-6-1
 EN 61000 (-4-2, -4-3, -4-4, -4-5, -4-6, -4-8, -4-11)

Michael J. Fahrion
 Michael J. Fahrion, Director of Engineering

CE



International Headquarters: 707 Dayton Road PO Box 1040 Ottawa, IL 61350 USA
 815-433-5100 Fax 433-5104 www.bb-elec.com orders@bb-elec.com support@bb-elec.com

European Headquarters: Westlink Commercial Park Oranmore Co. Galway Ireland
 +353 91 792444 Fax +353 91 792445 www.bb-europe.com orders@bb-europe.com support@bb-europe.com

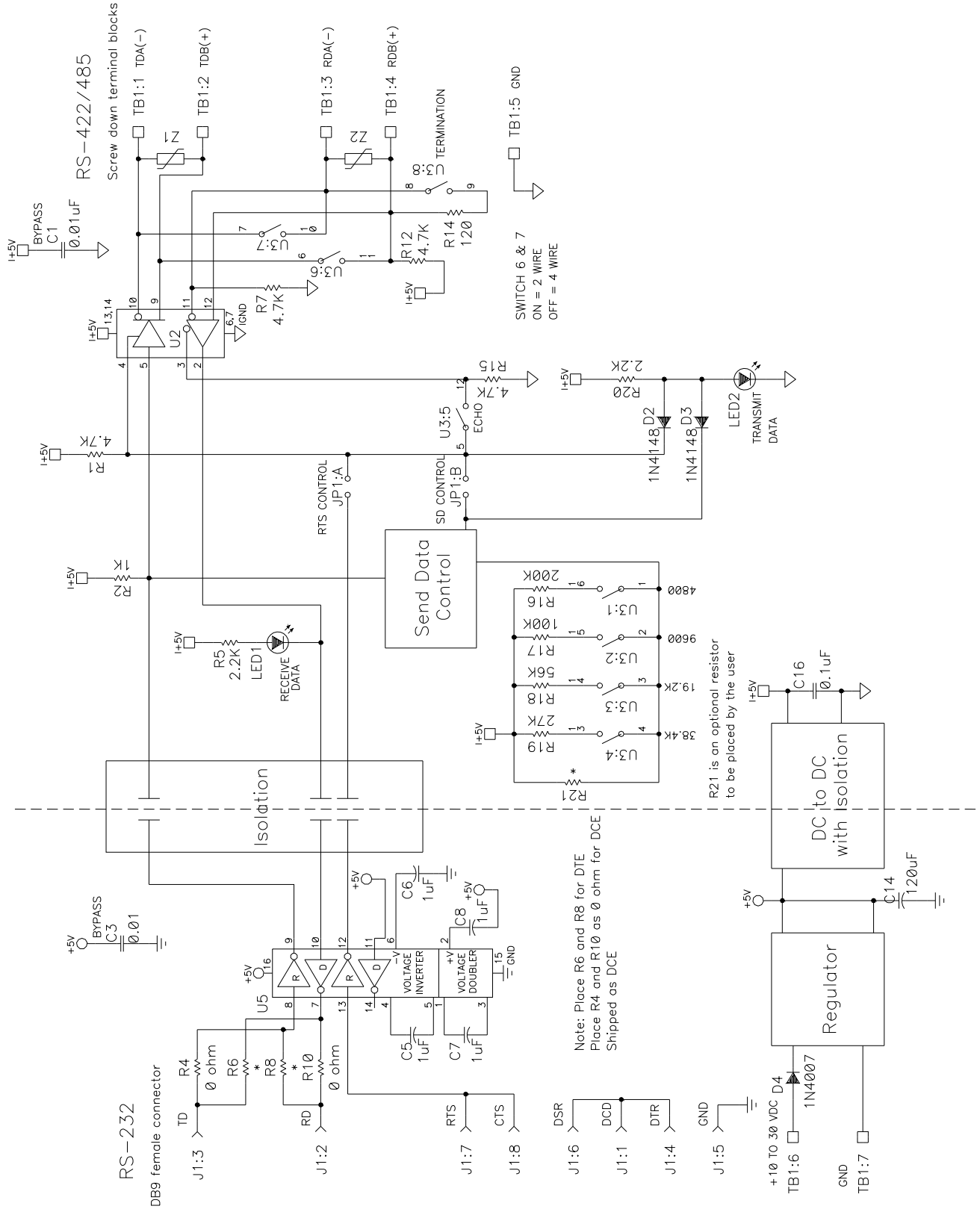

International Headquarters: 707 Dayton Road PO Box 1040 Ottawa, IL 61350 USA
815-433-5100 Fax 433-5104 www.bb-elec.com orders@bb-elec.com support@bb-elec.com

European Headquarters: Westlink Commercial Park Oranmore Co. Galway Ireland
+353 91 792444 Fax +353 91 792445 www.bb-europe.com orders@bb-europe.com support@bb-europe.com