

Quick Start Guide

485LDRC9

Optically Isolated RS-232 to RS-422/485 Converter



1

Check for All Required Hardware

- ❑ 485LDRC9 Serial Converter
- ❑ This Quick Start Guide
- ❑ Additional Items Required but not included
 - A 10 to 30 VDC Power Supply. The 485LDRC9 requires 0.5 Watts of power. Power is connected to the terminal block
 - RS-232 cable. RS-232 signals may be connected using the DB9F or terminal block. The converter is a DCE device.
 - RS-422/485 Cable. RS-422/485 Signals are connected using the terminal block.

2

Information - Agency Approvals



- ❑ FCC Class A
- ❑ CE

A detailed declaration of conformity is available for download at www.bb-elec.com



3

Information – Connectors

Figure 1- Connections and DIP Switch

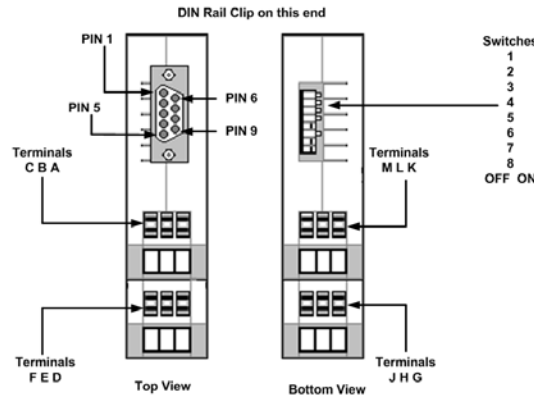

Table 1 – Terminal Block

Terminal Block	Signal	Direction
A	RS-232 Receive Data (RD)	Output
B	RS-232 Signal Ground (SG)	-----
C	Power Ground (PWR GND)	-----
D	RS-232 Transmit Data (TD)	Input
E	NOT USED	-----
F	10 – 30 VDC Power Input	-----
G	RS-422/485 TD A(-)	Output
H	RS-422/485 TD B(+)	Output
J	NOT USED	-----
K	RS-422/485 RD A(-)	Input
L	RS-422/485 RD B(+)	Input
M	Isolated Ground	-----

Note: Terminals will accept 12 to 24 AWG wire. Screw torque = 4 kgf-cm.

Table 2 – DB9 F Pins (Converter is DCE)

PIN	Signal	Direction
2	RS-232 Receive Data (RD)	Output
3	RS-232 Transmit Data (TD)	Input
5	RS-232 Signal Ground (SG)	-----

Note: On the DB9F Connector, control signals are looped back. Pin 1 (DCD), Pin 4 (DTR), and Pin 6 (DSR) are tied together. Pin 7 (RTS) and Pin 8 (CTS) are tied together.

4

Information - DIP Switch

Table 3 – Communications Mode

	SW-1	SW-2	SW-3	SW-4
RS-485 2-Wire Half Duplex	ON	ON	ON	ON
RS-485 4-Wire Full Duplex	ON	OFF	OFF	OFF
RS-422 Full Duplex	OFF	OFF	OFF	OFF

Table 4 – Termination Resistor

	SW-5
Use the 120Ω Built in Termination	ON
Use External or no termination	OFF

Table 5 – Timeout Selection

	SW-6	SW-7	SW-8	Timeout (MS)	#
1200	OFF	OFF	OFF	8.33	#
2400	OFF	OFF	ON	4.16	
4800	OFF	ON	OFF	2.08	
9600	ON	OFF	OFF	1.04	
19.2K	ON	ON	ON	0.580	
38.4K	OFF	OFF	OFF	0.260	#
57.6K	OFF	OFF	OFF	0.176	#
115.2K	OFF	OFF	OFF	0.0868	#

Timeout selections are equal to one character time at the indicated baud rate. Setting the converter 9600 will generally work at 9600 and higher baud rates. **In RS-422 mode, timeouts are not required.**

To achieve these timeouts you must place a through-hole resistor on the circuit board. See Step 5 for more information.

5

Through-hole resistor placement (Optional)

- If you need to support timeouts indicated with a # in Step 4, Table 5, you must place a through-hole resistor on the PCB. Place the resistor in the R-11 spot designated on the board. The R-11 location is clearly visible on the PCB.

Table 6 – Through-hole Resistor Values

Baud Rate	Timeout (MS)	R-11 Value
1200	8.33	820 KΩ
38.4K	0.260	27 KΩ
57.6K	0.176	16 KΩ
115.2K	0.0868	8.2 KΩ

7

RS-232 Connection

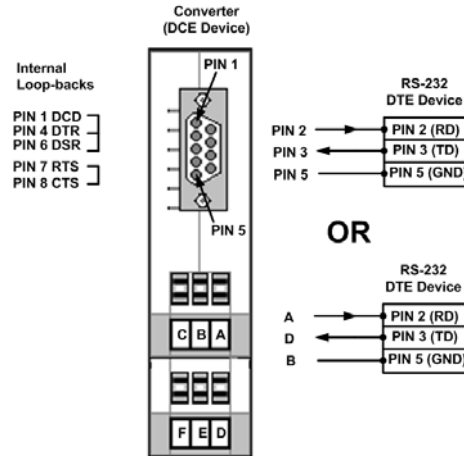

- RS-422/ Four Wire RS-485

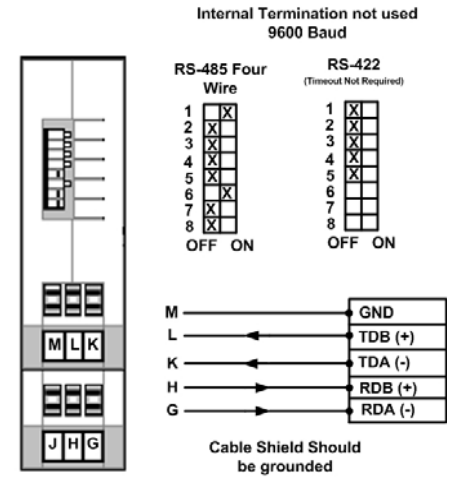

6

Power Connection

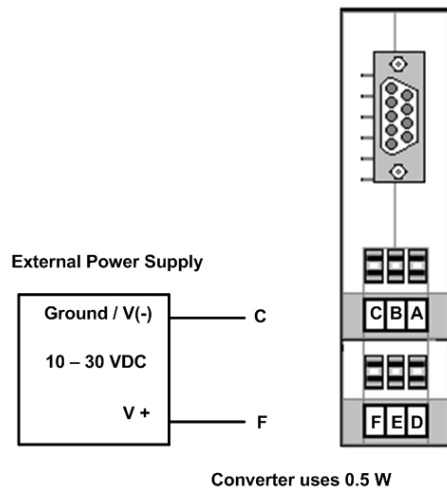

8

Wiring Examples

- Two Wire RS-485

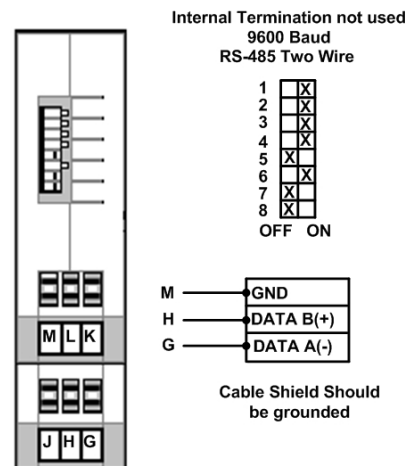

9

Loop Back Test / Troubleshooting

- Configure for RS-485 Four wire, 9600 baud
- Jumper terminals H to L and G to K
- Connect a PC to the RS-232 port (see Step 7).
- Using hyper terminal or similar program, connect to the appropriate COM port (remember to set the baud rate to 9600). Turn off hyper terminal local echo
- Transmit data. The same data should be returned
- LED Indicators: Power is ON when power is applied. TD flashes when RS-422/485 data is sent. RD flashes when RS-422/485 Data is received.

