

Five Port Expandable Smart Switch

Model 232XS5

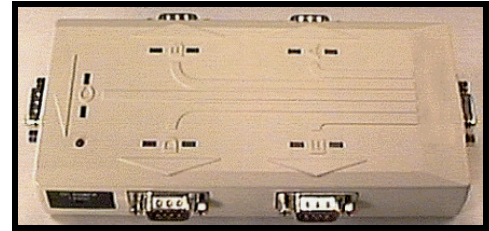

OVERVIEW

The RS-232 Five Port Expandable Smart Switch, Model 232XS5, allows one RS-232 host device to connect to five RS-232 devices. The 232XS5 can function as a software and/or hardware controlled switch. As a software controlled switch, referred to as smart switch mode, the device connected to the master port of the 232XS5 has control over which one of the five ports it is connected to. As a hardware controlled switch, referred to as port combiner mode, the handshake lines of the devices connected to the five ports are used to gain access to the master port. More details of smart switch and port combiner modes are covered later in this datasheet.

There are five LED's on the 232XS5 to indicate which port is connected to the master port. The master port has a DB-9S female connector and the slave ports have DB-9P male connectors. The master port can be configured as a DTE or DCE port by an internal switch setting. If the master port is configured as a DTE port, the five slave ports will become DCE ports. The 232XS5 supports the following signals: TD, RD, RTS, CTS, DCD, DSR and DTR. Handshake line DTR on the slave port can provide port power or be simply passed through from the master port. There is no delay through the device and data is not buffered. The 232XS5 will work with baud rates from 1200 to 115,200 bps; 7 or 8 data bits; even, odd or no parity; and 1 or 2 stop bits (7,N,1 is not allowed). The communication format is set via dipswitch 1 (SW1). In Expansion mode, up to four 232XS5 switches can be cascaded to form up to 17 slave ports.

NOTE: The data format and rates mentioned are used to switch the 232XS5. The communication between the devices can use any format or data rate.

OPERATION

The switch can be controlled in four different ways: smart switch, expansion mode, port combiner mode and enhanced timer mode.

Smart Switch Mode

In the **smart switch mode** or **code activated switch mode**, the switch is controlled by sending a programmable three character preamble code to the "Master" port of the 232XS5. The first character of the preamble code must be the ASCII "Escape" character (decimal 27). The second character is user programmable by setting DIP switch 2 (SW2). The third character should be the ASCII upper case letters A, B, C, D or E to select the appropriate port. The third character can also be the ASCII "EOT" (decimal 4) character which will turn off all the ports. Example: To select port "A", send the ASCII "ESC" character, the programmable character and the "A" character. When the 232XS5 receives this code the master port will be connected directly to port "A".

Expansion Mode

The 232XS5 can be operated in expansion mode where up to four switches can be cascaded to form up to 17 slave ports. Each unit address adds four serial slave ports to the chain with unit address "A" forming five ports as the last unit in the chain. The units are chained port C to the succeeding master. A four-character command is used to address each slave port. To address port D in unit address C, for example, a software command of "<ESC><STX><C><D>" would activate the proper port. In Expansion mode all units are set to this mode with a jumper and unit addresses from dipswitch SW1. Enhanced mode is available in Expansion mode, but Port Combiner mode is not.

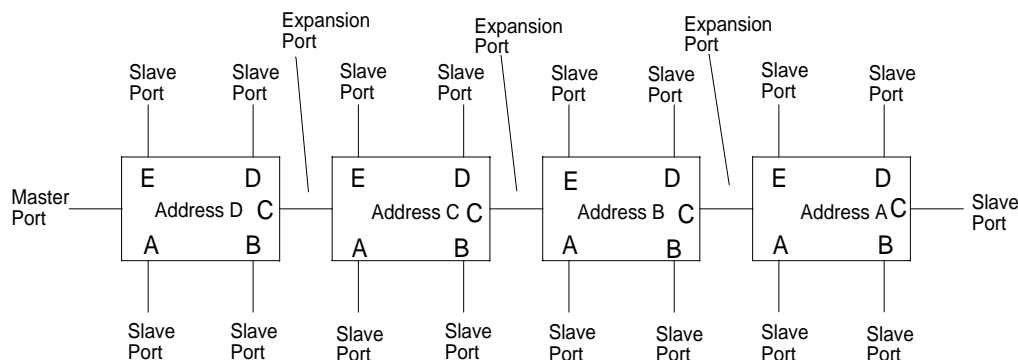

17-Port Cascaded Expansion Mode

© 1997 B&B Electronics - June 1997

B&B electronics
MANUFACTURING COMPANY

707 Dayton Road • PO Box 1040
Ottawa, IL 61350 USA
Phone: (815) 433-5100 • FAX: (815) 434-7094

Port Combiner Mode

In port combiner mode, a slave port can gain access to the master port by asserting a handshake line (RTS for DCE slave ports). If a slave port asserts its handshake line and no other slave ports have their handshake line asserted, the master port will then be connected directly to the slave port with the asserted handshake line. Once a slave port is connected to the master port, the connection will remain until the slave disasserts its handshake line. If multiple slave ports have their handshake lines asserted, access will be granted on a first come-first serve basis. If none of the slave ports have their handshake line asserted, the switch can be controlled using the preamble codes. For example: (Initial conditions -- no slave ports with handshake lines asserted) In chronological order, Port C asserts its handshake line, Port A asserts its handshake line, Port D asserts its handshake line and then Port C disasserts its handshake line. When Port C asserts its handshake line, a connection will be made between the master port and Port C. When Port C disasserts its handshake line, Port C will be disconnected and Port A will be connected to the master port. When Port A disasserts its handshake, Port A will be disconnected and Port D will be connected to the master port.

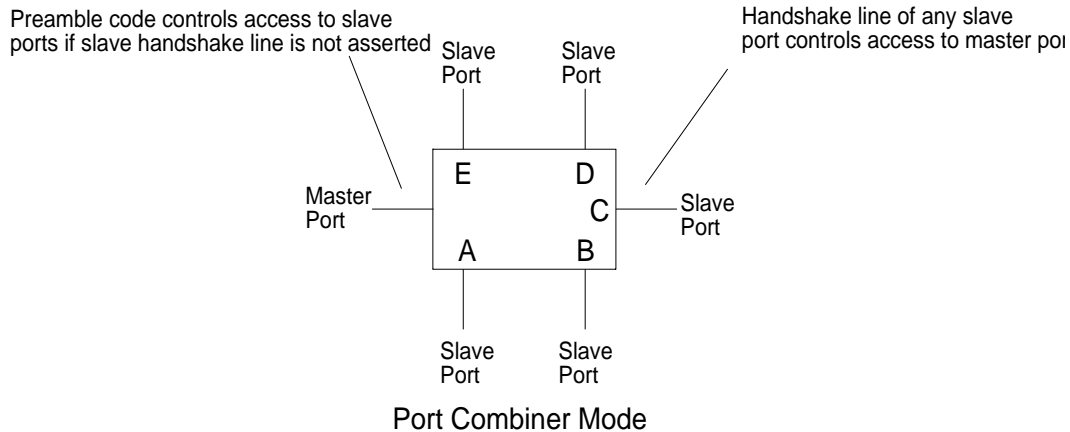

Enhanced Mode Timer Features

The 232XS5 has an enhanced mode, which offers special timer features. Enhanced mode is selected with a jumper. The timer features can be used to prevent slave devices from receiving preamble commands, inadvertent switching from binary/graphic file transfers, and inactive slave devices from holding control of the master port. The timer has two different modes: an **inactivity mode** and an **inadvertent switch mode**. When in inactivity mode, the 232XS5 will monitor the data lines. If there is no activity for the specified time, the selected slave port will be disconnected from the master port. When in inadvertent switch mode, the 232XS5 will ignore switching commands for the specified time. After this time has expired, the selected slave port will be disconnected from the master port.

The timer functions are enabled via a jumper setting and through software commands. The software commands follow the same format as preamble codes used for switching. There are two commands used to set the timer functions: Set Timer Mode and Set Timer Value. These commands require an additional byte for data. The Set Timer Value command requires the third byte to be an ASCII "T" character. The data byte (fourth byte) must be a value between ASCII "0" and ASCII "9". A value of "0" is used to disable the timer.

The Set Timer Mode command requires the third byte to be an ASCII "M". If the data byte (fourth byte) is an ASCII "0" (default), the timer will be setup as an inactivity timer. With the timer is configured as an inactivity timer, the 232XS5 will monitor the data lines (TD & RD) for data. If there is no activity for the specified timer value, the slave port that is connected to the master port will be disconnected. In smart switch mode, the inactivity timer can be used to prevent the preamble codes from being received by the slave devices. In port combiner mode, the inactivity timer can be used to prevent devices from tying up the master port. For example (port combiner mode): All the slave ports have their handshake lines asserted. The device on Port C has its handshake line asserted and is currently connected to the master port, but has not been transmitting or receiving data. When the inactivity timer expires, Port C will be disconnected and the next slave port will then be connected to the master port (following the first come-first serve rule). Port C will then be placed at the "end of the line".

If the data byte of the Set Timer Mode command is an ASCII "1", the timer will be set up to ignore switching commands. When the timer is configured in this mode, the 232XS5 will not accept any switching commands ("A", "B", "C", "D", "E" or "EOT") for the specified timer value. After the timer has expired the slave port that is connected to the master port will be disconnected. This feature is useful to prevent inadvertent switching during binary/graphic type file transfers. For example (smart switch mode): the timer is configured to ignore switching commands for 5 seconds. The select Port D command is sent to the 232XS5. Once Port D is connected a file of unknown data type (so file may or may not contain a switching command sequence) is to be transferred through the 232XS5. For a period of 5 seconds after Port D is connected, no switching commands will be accepted. As long as the file transfer takes less than 5 seconds, there is no chance the 232XS5 will inadvertently switch ports.

RS-485 Ports

Using the 485SD9TB RS-232 to RS-485 converter or the recommended device, the 232XS5 RS-232 slave ports may be used to provide active 2-wire RS-485 compatibility. Port power can be provided to a slave port on the DTR line (pin 4) via a jumper to provide power to drive a 485SD9TB RS-232 to RS-485 converter (sold separately).

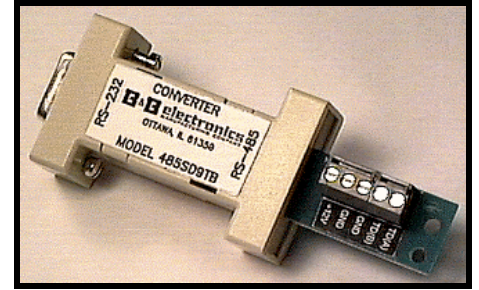

Instruction Manual and Diskette

The 232XS5 comes with an instruction manual and 3.5" diskette. An IBM PC or compatible terminal stay resident (TSR) program is supplied. The program allows the user to select the Smart Switch ports either through the command line or by pressing a sequence of keys, referred to as hot keys. The TSR requires 1K of memory. Also included is a program written in Visual Basic which allows you to switch ports in Windows (3.1).

Power Supply

The 232XS5 requires 12Vdc at 100mA, which is provided through a 2.5mm power jack. The tip of the plug is positive and the shaft of the plug is ground. A power supply is available (Model 232PS).

Specifications

Model: 232XS5

Power: 12Vdc to 16Vdc @ 100mA

Dimensions: 5.5" L x 3.0" W x 1.0" H