

Model: 232CLDR
DIN Rail Mountable RS-232
to Current Loop $\mathcal{C}\mathcal{E}$
with Terminal Blocks

Overview

The 232CLDR is a DIN rail mountable version of B&B's RS-232 to current loop converter. This unit has one optically isolated 20mA transmit loop and one optically isolated 20mA receive loop. Each loop can be set to either "Active" or "Passive". When set to "Active" an isolated 20mA current is supplied for each loop (transmit and receive). Only a single power supply between 10VDC and 30VDC is required to power the converter and both current loops. Terminal block (A) is RS-232 OUT (from the 232CLDR) and terminal block (D) is RS-232 IN (to the 232CLDR). The 232CLDR can communicate at a maximum baud rate of 19.2K baud. 20mA current loop is suitable for distances to 2000 ft. (600 meters) at data rates up to 19.2K baud with careful attention to interface design. Below are several figures that show different ways to test and configure the 232CLDR.

Active or Passive

The 232CLDR can be set to active or passive by the flip of a switch. Figures 1-4 show four different ways to configure the 232CLDR using two PC's. To set SW1 and SW2 you will need to open the hood on the 232CLDR. To open the 232CLDR remove the side panel by using a flat blade screwdriver. Push the flat blade screwdriver under the panel that has the "Model 232CLDR" label on it and pry the panel off. This panel will simply snap off (and on). The two-position dipswitch is located on the printed circuit board.

Tables 1 and 2 (Transmit and Receive respectively), show connection configurations for active and passive modes. If you have a separate current loop device (printer, scale, CNC, etc.) you may have to check your device documentation to see if it is configured as active or passive. If you do not know if your device is active or passive you can simply check it with a voltmeter. To do this set the voltmeter to DC Volts and put the positive (red) lead on the T+ and the black (negative) lead on the T- of the current loop device. If you see a voltage displayed on the voltmeter your device is active. If no voltage appears your device is passive.

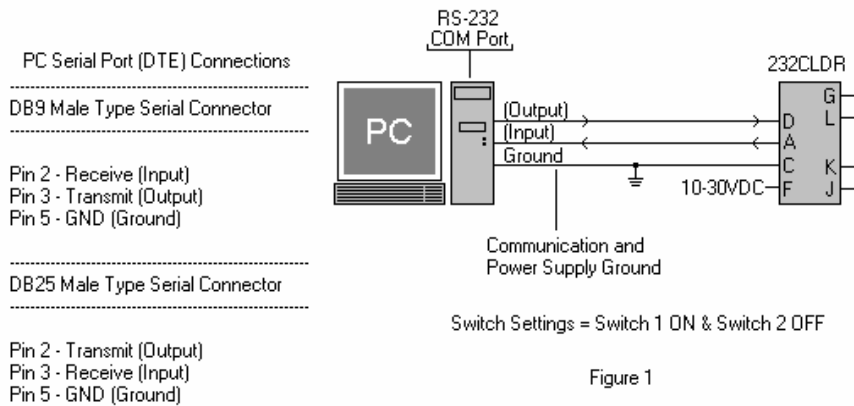

Figure 1
Figure 1 is a loopback test for the Model 232CLDR. This will verify the Model 232CLDR is operating properly. Characters will be sent from the RS-232 Port of the PC and received back into the PC RS-232 Port through the 232CLDR.

International Headquarters:

B & B Electronics Mfg. Co. 707 Dayton Road P.O. Box 1040 Ottawa, IL 61350 USA
815-433-5100 Fax 433-5104 www.bb-elec.com orders@bb-elec.com support@bb-elec.com

B & B Electronics Ltd Westlink Commercial Park Oranmore Co. Galway Ireland
+353 91 792444 Fax +353 91 792445 www.bb-europe.com orders@bb-elec.com support@bb-europe.com

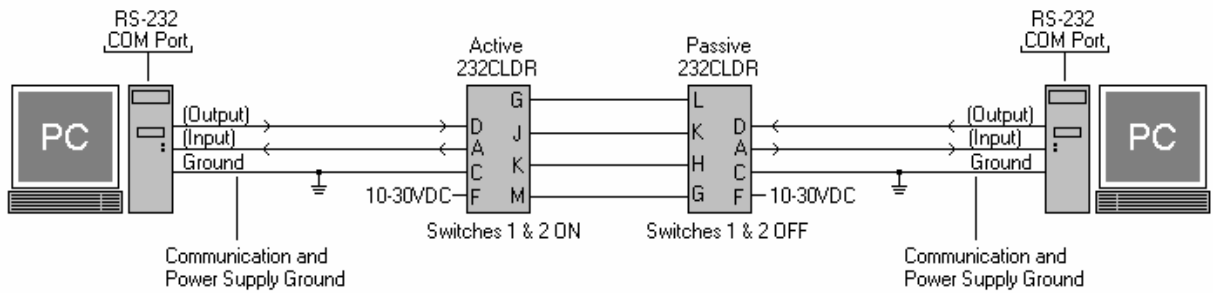

Figure 2

Figure 2 is an example of interfacing two Model 232CLDR converters. The 232CLDR on the left is configured as "active" and the 232CLDR on the right is configured as "passive".

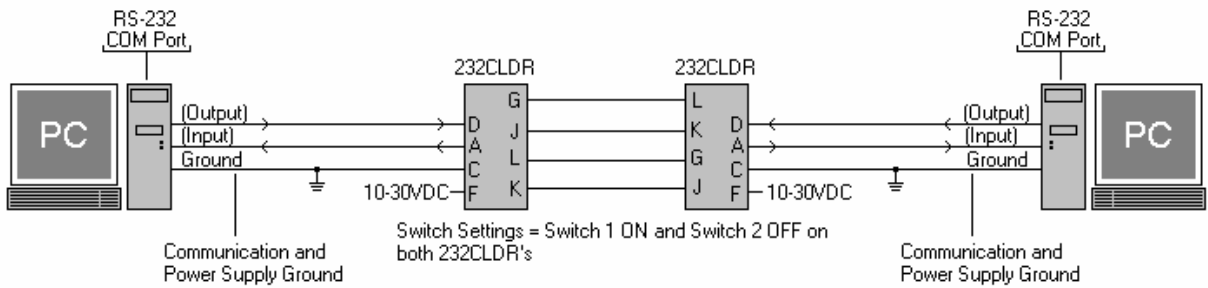

Figure 3

Figure 3 is a connection diagram that shows "active" transmit and "passive" receive on both 232CLDR's.

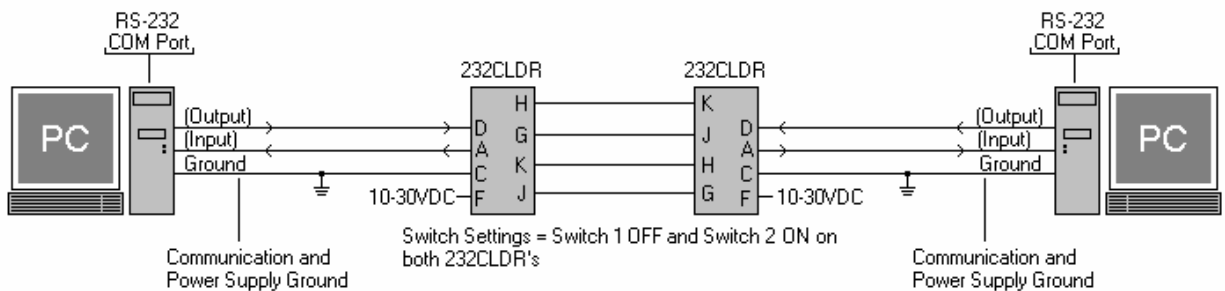

Figure 4

Figure 4 is a connection diagram that shows "active" receive and "passive" transmit on both 232CLDR's.

International Headquarters:

B & B Electronics Mfg. Co. 707 Dayton Road P.O. Box 1040 Ottawa, IL 61350 USA
815-433-5100 Fax 433-5104 www.bb-elec.com orders@bb-elec.com support@bb-elec.com

B & B Electronics Ltd Westlink Commercial Park Oranmore Co. Galway Ireland
+353 91 792444 Fax +353 91 792445 www.bb-europe.com orders@bb-elec.com support@bb-europe.com

Table 1: Transmit

	SW1	H	G	J
Active	On	NC	Connect to R+	Connect to R-
Passive	Off	Connect to R+	Connect to R-	NC

Table 2: Receive

	SW2	L	K	M
Active	On	NC	Connect to T+	Connect to T-
Passive	Off	Connect to T+	Connect to T-	NC

Typical Applications

Figure 5 is a typical application of an “active” current loop scale and the 232CLDR configured in “passive” mode. Some scale manufacturers sell weight scales that have a current loop interface. A different “active” current loop device of your choice could easily replace the scale. This figure simply portrays the basic idea of connecting an “active” (Transmit only) current loop device to the 232CLDR (configured as “passive”).

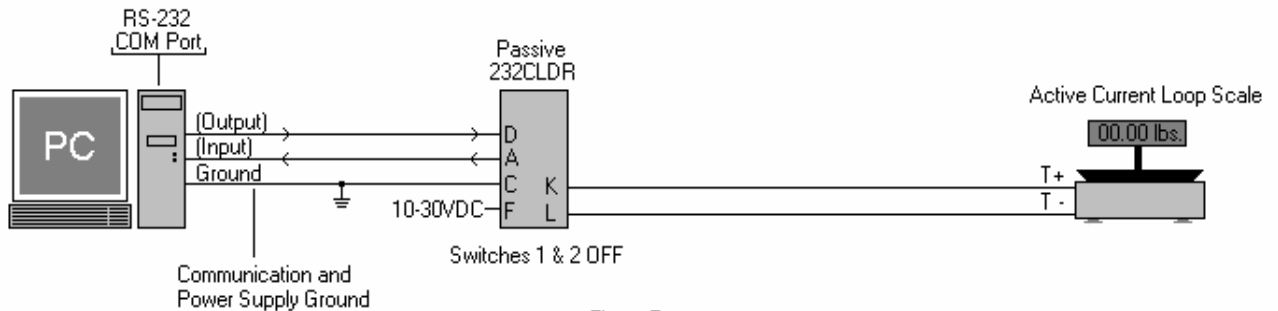

Figure 5
Typical Current Loop Scale Application

Specifications

- Dimensions: 1.0 x 3.1 x 4.16 in (25.1 x 78.8 x 105.6 mm)
- Temperature Range: 0 to 80°C (32 to 176°F)
- Humidity Range: 0 to 95% Non-condensing
- Supply Voltage: +10 to 30VDC @ 100mA
- Data Rates: Up to 19.2kbs
- Connectors: Screw down terminal blocks for RS-232 and current loop sides
- LED's: Two RED data LED's show direction of data flow
- Isolation: 1000 VDC isolation for 1 second

International Headquarters:

B&B Electronics Mfg. Co. 707 Dayton Road P.O. Box 1040 Ottawa, IL 61350 USA
815-433-5100 Fax 433-5104 www.bb-elec.com orders@bb-elec.com support@bb-elec.com

B&B Electronics Ltd Westlink Commercial Park Oranmore Co. Galway Ireland
+353 91 792444 Fax +353 91 792445 www.bb-europe.com orders@bb-elec.com support@bb-europe.com

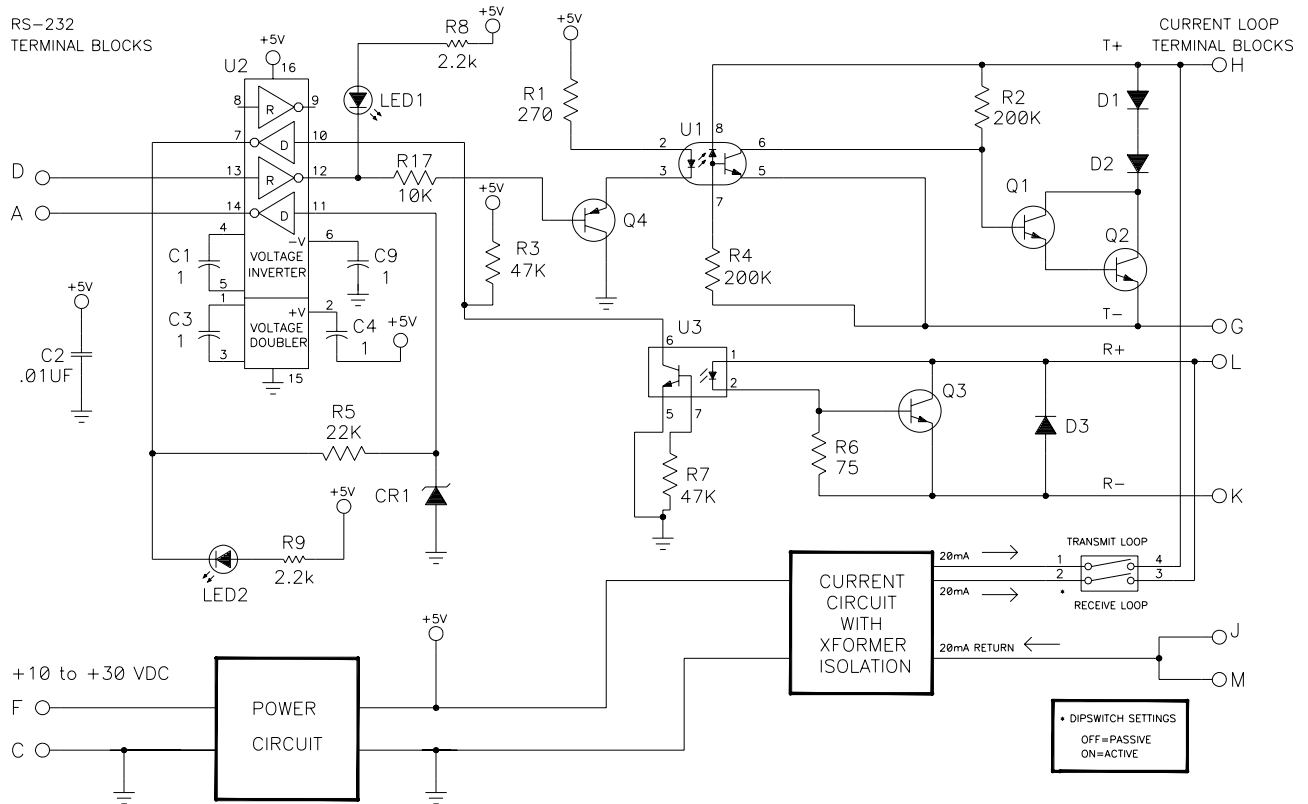
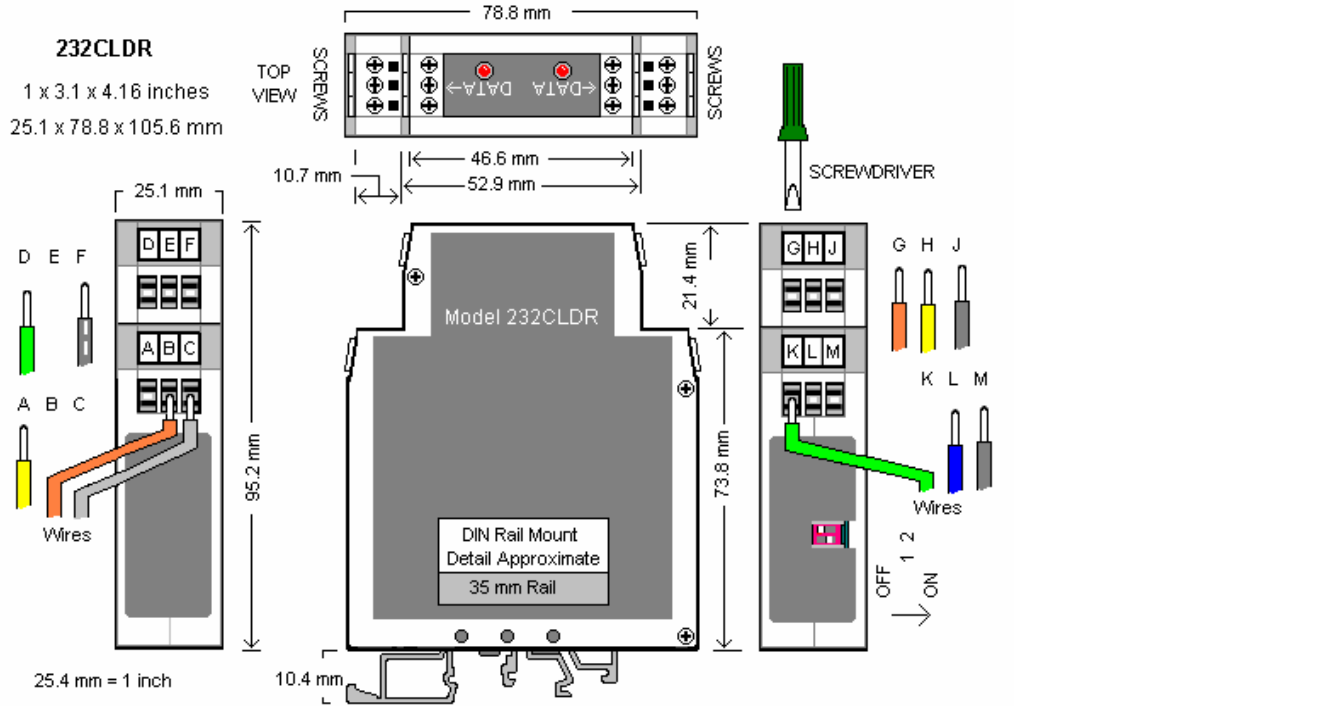

Figure 7. 232CLDR Schematic

International Headquarters:

B&B Electronics Mfg. Co. 707 Dayton Road P.O. Box 1040 Ottawa, IL 61350 USA
815-433-5100 Fax 433-5104 www.bb-elec.com orders@bb-elec.com support@bb-elec.com

B&B Electronics Ltd Westlink Commercial Park Oranmore Co. Galway Ireland
+353 91 792444 Fax +353 91 792445 www.bb-europe.com orders@bb-elec.com support@bb-europe.com